

Control Systems

2013



TROX[®] TECHNIK

The art of handling air

Control Systems

2013

The Control Units catalogue corresponds to sections 5.1, 5.2 and 5.4 of the previously used KLIMA 2 catalogue.

The TROX catalogues have been completely revised and now offer several new features:

- Hardcover editions
- Simplified navigation
- List of advantages of each product at a glance
- Different chapters for principal products, additional components and attachments

The following documentation is available to help you select and size TROX components and systems:

- Technical product documentation (catalogues)
- Design manuals
- Easy Product Finder design programme
- Compendium CD
- Website www.troxtechnik.com

This catalogue is a carbon neutral product.

TROX[®] TECHNIK

The art of handling air

TROX GmbH

Heinrich-Trox-Platz

D-47504 Neukirchen-Vluyn

Phone +49(0)2845202-0

Fax +49(0)2845202-265

E-Mail trox@trox.de

www.troxtechnik.com



Diffusers



Air-Water Systems/Decentralised Ventilation



Multileaf Dampers Attenuators/ External Weather Louvres



Fire and Smoke Protection Systems



Control Units



Control Systems

The Control Systems catalogue corresponds to sections 5.3 of the previously used KLIMA 2 catalogue.

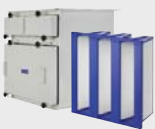

Filter Units/Filter Elements



X-CUBE – Air Handling Units

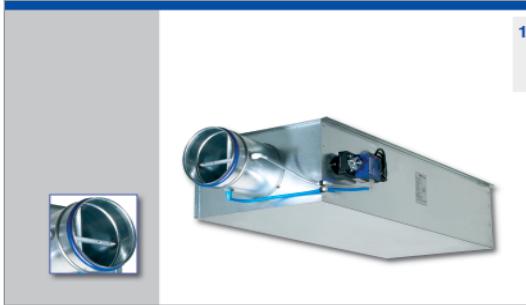

Technical document, or leaflet

Technical product documentation

- ... comprise:
- Product descriptions
 - Information on the materials used
 - Aerodynamic and acoustic data
 - Dimensions
 - Details on product characteristics
 - Specification texts



Design manual

Design manuals

- ... comprise:
- Basic information and technical concepts
 - Step-by-step product design
 - Overview and explanation on how to select the ideal system components

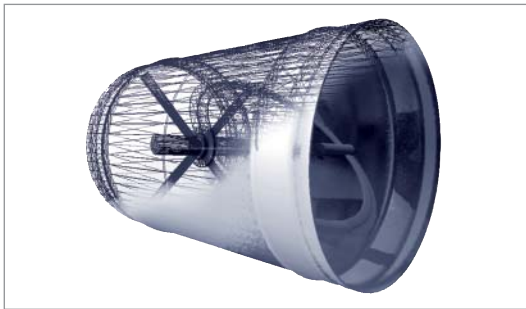

Design programme

Easy Product Finder design programme

- ... comprises everything to select and size TROX products:
- Technical data
 - Diagrams, photos
 - Order codes that can be edited
 - CAD drawings(3D model; export function for DXF and other standard formats)
 - Specification texts for each product and variant

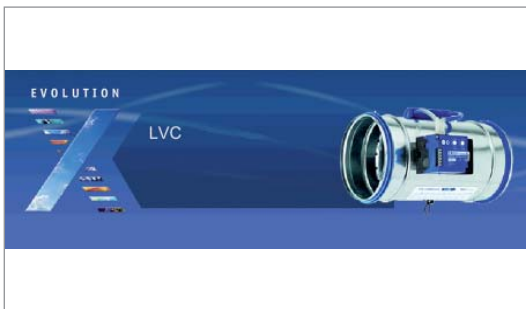

Internet

Website www.troxtechnik.com

The entire documentation is available on the internet.

- Catalogue download center
- Individual product leaflets
- Installation examples
- References

Page numbering

K5 – 0.0 – 6

TROX® TECHNIK

04/2013 – DE/en

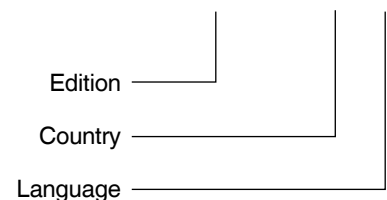
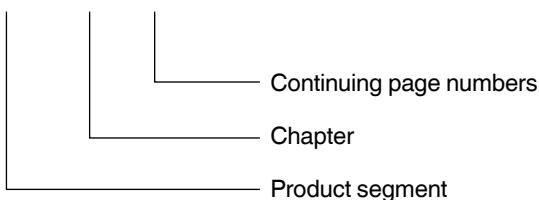

K6 – 0.0 – 6

TROX® TECHNIK

04/2013 – DE/en



1 Variable volume flow control – LABCONTROL

- 1.1 VAV terminal units**
- 1.2 Secondary silencers for VAV terminal units**
- 1.3 Basic information and nomenclature**



2 Air management control systems

- 2.1 Controller**
- 2.2 Monitoring systems**
- 2.3 Expansion modules**
- 2.4 Sensor systems**
- 2.5 Control panels**
- 2.6 Configuration software**
- 2.7 Basic information and nomenclature**

Additional information

- Z – 1 Product index**
- Z – 2 Disclaimer**
- Z – 3 TROX contact information**

Table of contents

1



1 Variable volume flow control – LABCONTROL

VARYCONTROL VAV terminal units are air terminal units for supply air and extract air systems. They work with an external power supply and can be used for controlling, flow adjustment, or shutting off the airflow in room air conditioning systems. Depending on their construction the units can meet the most demanding acoustic requirements; different materials and surface finishes are also available. Additional construction variants for VAV terminal units can be found in the Klima 5 catalogue.

1.1 VAV terminal units

Type

Page

Optimum resistance



Optimised for use in laboratories and on fume cupboards

TVLK

1.1 – 1

1.2 Secondary silencers for VAV terminal units

Optimum resistance



For the reduction of noise in plastic circular ducts, suitable for all circular VAV terminal units and CAV controllers, plastic construction for contaminated air

CAK

1.2 – 1

1.3 Basic information and nomenclature



Air management control systems

1.3 – 1



Easy cleaning of sensor tubes



Variant with Venturi nozzle and connecting circular spigot



Variant with bluff body and flange

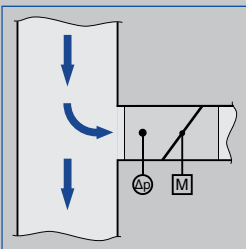

For all upstream conditions



Tested to VDI 6022

VAV terminal units

Type TVLK



Optimised for use in laboratories and on fume cupboards

Plastic circular VAV terminal units for aggressive extract air in laboratories and production facilities

- Casing and damper blade made of flame-resistant polypropylene
- Compact construction, only 400 mm long
- High control accuracy even in case of unfavourable upstream conditions
- Combination with fast-running actuators (air management systems)
- Volume flow rate measurement with bluff body or Venturi nozzle
- Slide-out differential pressure sensor allows for easy cleaning
- Closed blade air leakage to EN 1751, class 4
- Casing air leakage to EN 1751, class C

Optional equipment and accessories

- With flanges on both ends
- Plastic secondary silencer Type CAK for the reduction of air-regenerated noise

1

Type		Page
TVLK	General information	1.1 – 2
	Order code	1.1 – 5
	Aerodynamic data	1.1 – 7
	Sizing	1.1 – 9
	Dimensions and weight – TVLK	1.1 – 10
	Dimensions and weight – TVLK-FL	1.1 – 11
	Specification text	1.1 – 12
	Basic information and nomenclature	1.3 – 1

Variants

Product examples

VAV terminal unit Type TVLK with bluff body and connecting circular spigot



VAV terminal unit Type TVLK with bluff body and flange



VAV terminal unit Type TVLK with Venturi nozzle and connecting circular spigot



VAV terminal unit Type TVLK with Venturi nozzle and flange



Description

For detailed information on the LABCONTROL control system see Chapter K6 – 2.

For detailed information on control components see the Control units catalogue, chapter K5 – 1.3.

Application

- Circular LABCONTROL VAV terminal units of Type TVLK, made of plastic, to control the volume flow rate of fume cupboards and fume hoods
- Suitable for contaminated air
- Closed-loop volume flow control using an external power supply
- Shut-off by means of switching (equipment supplied by others)

Variants

- TVLK: VAV terminal unit
- TVLK-FL: VAV terminal unit with flanges on both ends

Nominal sizes

- Bluff body: 250 – 100, 250 – 160
- Venturi nozzle: 250 – D10, 250 – D16
- Bluff body and Venturi nozzle available in two sizes each for different volume flow rate ranges

Attachments

- LABCONTROL: Control components for air management systems
- Universal controller: Controller, differential pressure transducer and actuators for special applications

Accessories

- Matching flanges for both ends

Useful additions

- Plastic secondary silencer Type CAK for demanding acoustic requirements

Special features

- High control accuracy even in case of unfavourable upstream conditions
- Integral slide-out differential pressure sensor with 3 mm measuring holes (resistant to dust and pollution)
- No metal parts come into contact with the airflow
- Factory set-up or programming and aerodynamic function testing
- Volume flow rate can be measured and subsequently adjusted on site; additional adjustment tool or configuration software may be necessary

Parts and characteristics

- Ready-to-operate unit which consists of the mechanical parts and the control components
- Averaging differential pressure sensor for volume flow rate measurement; can be removed for cleaning
- Control damper blade
- Factory-assembled control components complete with wiring and tubing
- Aerodynamic function testing on a special test rig prior to shipping of each unit
- Unit carries test label with relevant data

Construction features

- Circular casing
- Short casing: 392 mm without flange, 400 mm with flange
- Spigot connection suitable for ducts according to DIN 8077
- Both spigots with same diameter (250 mm)
- Position of the damper blade indicated externally at shaft extension

Materials and surface

- Casing and damper blade made of flame-resistant polypropylene (PP), flammability to UL 94, V-0
- Differential pressure sensor (bluff body or Venturi nozzle) and plain bearing made of polypropylene (PP)
- Damper blade seal made of thermoplastic elastomers (TPE)

Installation and commissioning

- Installation orientation must be as shown on the sticker

Standards and guidelines

- Hygiene conforms to VDI 6022.
- Closed blade air leakage to EN 1751, class 4, meets the requirements of DIN 1946, part 4
- Casing air leakage to EN 1751, class C

Maintenance

- Maintenance-free as construction and materials are not subject to wear
- Zero point correction of the static differential pressure transducer should be carried out once per year (recommendation)

Technical data

Nominal sizes	250 mm
Volume flow rate range	30 – 360 l/s
Volume flow rate range	108 – 1296 m ³ /h
Volume flow rate control range	approx. 15 to 100 % of the nominal volume flow rate
Differential pressure	5 – 1000 Pa
Operating temperature	10 – 50 °C

Function

Functional description

For measuring the volume flow rate the VAV terminal unit is fitted either with a bluff body and a differential pressure sensor or with a Venturi nozzle.

The control components (attachments) include a differential pressure transducer that transforms the differential pressure into an electric signal, a controller, and an actuator.

- Fume cupboard control: The volume flow rate setpoint depends on the control strategy for the fume cupboard and is based on the face velocity, the sash position, or a constant value.
- Volume flow rate control: The volume flow rate setpoint comes from an external unit or device.

The controller compares the actual value with the setpoint value and alters the command signal of the actuator if there is a difference between the two values.

Schematic illustration of the TVLK

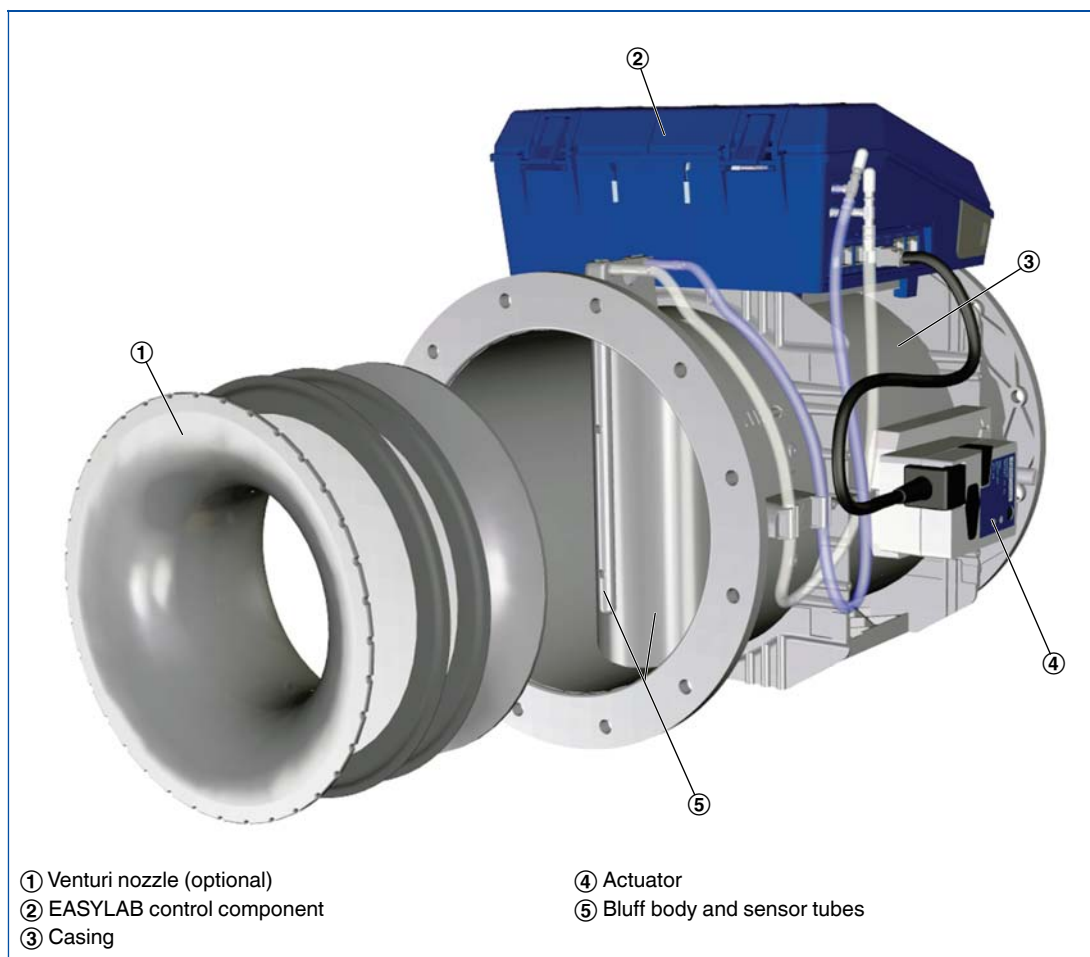

Order code

TVLK with EASYLAB for fume cupboard control

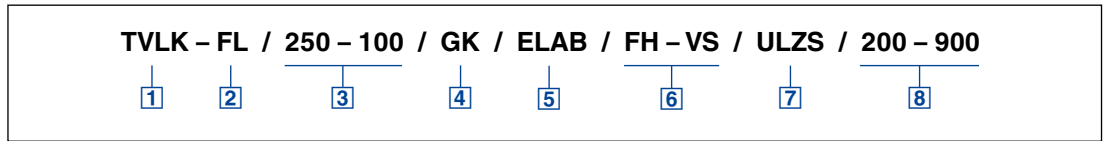

1 Type

TVLK VAV terminal unit made of plastic

2 Flange

No entry: none

FL Flanges on both ends

3 Nominal size

250 – 100 Bluff body 100

250 – 160 Bluff body 160

250 – D10 Venturi nozzle D10

250 – D16 Venturi nozzle D16

4 Accessories

No entry: none

GK Matching flanges for both ends

5 Control component

ELAB EASYLAB controller TCU3 with fast-running actuator

6 Equipment function – fume cupboard control

With face velocity transducer

FH-VS Face velocity control

With sash distance sensor

FH-DS Linear control strategy

FH-DV Safety-optimised control strategy

With switching steps for on-site switch contacts

FH-2P 2 switching steps

FH-3P 3 switching steps

Without signalling

FH-F Volume flow rate constant value

7 Expansion modules

Option 1: Supply voltage

No entry: 24 V AC

T EM-TRF for 230 V AC

U EM-TRF-USV for 230 V AC, provides uninterruptible power supply (UPS)

Option 2: Communications interface

No entry: none

L EM-LON for LonWorks FTT-10A

B EM-BAC-MOD-01 for BACnet MS/TP

M EM-BAC-MOD-01 for Modbus RTU

Option 3: Automatic zero point correction

No entry: none

Z EM-AUTOZERO Solenoid valve for automatic zero point correction

Option 4: Lighting

No entry: none

S EM-LIGHT Wired socket for the connection of lighting and for switching the lighting on/off using the control panel (only with EM-TRF or EM-TRF-USV)

8 Operating values [m³/h or l/s]

Depending on the equipment function

FH-VS: $\dot{V}_{\min} - \dot{V}_{\max}$

FH-DS: $\dot{V}_{\min} - \dot{V}_{\max}$

FH-DV: $\dot{V}_{\min} - \dot{V}_{\max}$

FH-2P: \dot{V}_1 / \dot{V}_2

FH-3P: $\dot{V}_1 / \dot{V}_2 / \dot{V}_3$

FH-F: \dot{V}_1

Useful additions

Control panel for fume cupboard controllers, for displaying the functions of the control system according to EN 14175

BE-SEG-** with 2-character display

BE-LCD-01 with 40-character display

Order example

TVLK/250-100/ELAB/FH-VS/200-900 m³/h

Nominal size 250, with bluff body 100

Control component EASYLAB controller with fast-running actuator

Equipment function Fume cupboard control with face velocity transducer

Volume flow rate 200 – 900 m³/h

Order code

TVLK with TCU-LON-II for fume cupboard control

TVLK – FL / 250 – 100 / GK / TMB / FH / 200 – 900

1 2 3 4 5 6 7

1 Type

TVLK VAV terminal unit made of plastic

2 Flange

No entry: none

FL Flanges on both ends

3 Nominal size [mm]

250 – 100 Bluff body 100

250 – 160 Bluff body 160

250 – D10 Venturi nozzle D10

250 – D16 Venturi nozzle D16

4 Accessories

No entry: none

GK Matching flanges for both ends

5 Control components

TMA TCU-LON-II with fast-running actuator

TMB TCU-LON-II with fast-running actuator
(brushless motor)

6 Equipment function

FH Fume cupboard

Face velocity control with face velocity transducer

7 Operating values [m³/h or l/s]

FH: $\dot{V}_{\min} - \dot{V}_{\max}$

Useful additions

Control panel for fume cupboard controller, for displaying the functions of the control system according to EN 14175

BE-TCU-LON-II

Order example

TVLK-FL/250-D16/GK/TMA/FH/250-700 m³/h

Flanges both ends

Nominal size 250 with Venturi nozzle D16

Accessories matching flanges

Control component TCU-LON II
with fast-running actuator

Equipment function fume cupboard

Volume flow rate 250 – 700 m³/h

Volume flow rate ranges

The minimum differential pressure of VAV terminal units is an important factor in designing the ductwork and in rating the fan including speed control.

Sufficient duct pressure must be ensured for all operating conditions and for all control units. The measurement points for the speed control must be selected accordingly.

Volume flow ranges and minimum pressure differences for the TVLK with EASYLAB or TCU-LON II

Nominal size	\dot{V}		①	②	③	④	$\Delta\dot{V}$ ± %
	l/s	m ³ /h	$\Delta p_{st\ min}$				
			Pa	Pa	Pa	Pa	
250-100	55	198	5	5	5	5	10
	140	504	15	15	15	15	7
	220	792	35	35	35	35	6
	360	1296	85	85	85	90	5
250-160	30	108	5	5	5	5	10
	80	288	25	25	25	25	7
	120	432	50	50	50	50	6
	195	702	130	130	130	130	5
250-D10	55	198	5	5	5	5	10
	140	504	10	10	10	10	7
	220	792	20	20	20	20	6
	360	1296	50	50	55	55	5
250-D16	30	108	5	5	5	5	10
	80	288	15	15	15	15	7
	120	432	30	30	30	30	6
	195	702	70	70	75	75	5

- ① TVLK
- ② TVLK with circular silencer CAK, insulation thickness 50 mm, length 500 mm
- ③ TVLK with circular silencer CAK, insulation thickness 50 mm, length 1000 mm
- ④ TVLK with circular silencer CAK, insulation thickness 50 mm, length 1500 mm

Upstream conditions

The volume flow rate accuracy $\Delta\dot{V}$ applies to all upstream conditions.

Bend

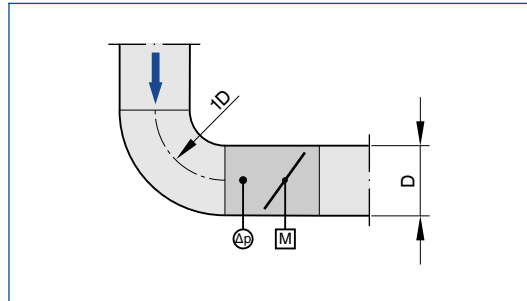

A bend with a curvature radius of at least 1D – without an additional straight duct section upstream of the VAV terminal unit – has only a negligible effect on the volume flow rate accuracy.

Junction

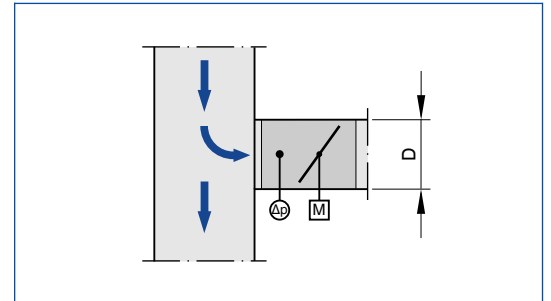

The stated volume flow rate accuracy $\Delta\dot{V}$ will be achieved even when the VAV terminal unit is installed at a junction. Even the installation on the dome of a fume cupboard will have no adverse effect.

1 Volume flow rate ranges

The minimum differential pressure of VAV terminal units is an important factor in designing the ductwork and in rating the fan including speed control.

Sufficient duct pressure must be ensured for all operating conditions and for all control units. The measurement points for the speed control must be selected accordingly.

Volume flow rate ranges and minimum differential pressure values for the TVLK with Universal controller

Nominal size	\dot{V}		①	②	③	④	$\Delta\dot{V}$
			$\Delta p_{st \min}$				
	l/s	m ³ /h	Pa	Pa	Pa	Pa	± %
250-100	65	234	5	5	5	5	10
	180	648	25	25	25	25	7
	290	1044	55	55	55	60	6
	360	1296	85	85	85	90	5
250-160	35	126	5	5	5	5	10
	100	360	35	35	35	35	7
	160	576	90	90	90	90	6
	195	702	130	130	130	130	5
250-D10	65	234	5	5	5	5	10
	180	648	15	15	15	15	7
	290	1044	35	35	35	35	6
	360	1296	50	50	55	55	5
250-D16	35	126	5	5	5	5	10
	100	360	20	20	20	20	7
	160	576	50	50	50	50	6
	195	702	70	70	75	75	5

① TVLK

② TVLK with circular silencer CAK, insulation thickness 50 mm, length 500 mm

③ TVLK with circular silencer CAK, insulation thickness 50 mm, length 1000 mm

④ TVLK with circular silencer CAK, insulation thickness 50 mm, length 1500 mm

Upstream conditions

The volume flow rate accuracy $\Delta\dot{V}$ applies to all upstream conditions.

Bend

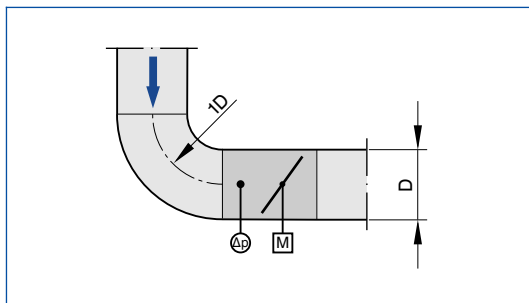

A bend with a curvature radius of at least 1D – without an additional straight duct section upstream of the VAV terminal unit – has only a negligible effect on the volume flow rate accuracy.

Junction

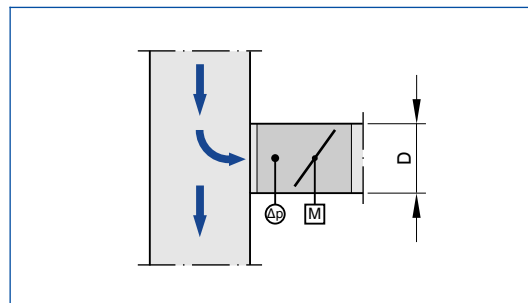

The stated volume flow rate accuracy $\Delta\dot{V}$ will be achieved even when the VAV terminal unit is installed at a junction. Even the installation on the dome of a fume cupboard will have no adverse effect.

Air-regenerated noise

Quick sizing tables provide a good overview of the room sound pressure levels that can be expected. Approximate intermediate values can be interpolated. Precise intermediate values and spectral data can be calculated with our Easy Product Finder design programme.

The first selection criteria for the nominal size are the actual volume flow rates \dot{V}_{\min} and \dot{V}_{\max} . The sizing tables are based on normally accepted attenuation levels. If the sound pressure level exceeds the required level, a larger air terminal unit and/or a silencer is required.

Quick sizing: Sound pressure level at differential pressure 150 Pa TVLK with EASYLAB or TCU-LON-II

Nominal size	\dot{V}		Air-regenerated noise				Case-radiated noise
			①	②	③	④	①
	l/s	m ³ /h	L _{PA}	L _{PA1}			L _{PA2}
							dB(A)
250-100	55	198	40	33	29	26	26
	140	504	46	38	34	31	33
	220	792	47	39	35	31	37
	360	1296	48	39	35	32	42
250-160	30	108	37	32	28	25	22
	80	288	41	35	31	28	29
	120	432	43	37	33	30	32
	195	702	49	42	38	35	40
250-D10	55	198	36	28	24	21	24
	140	504	42	34	30	27	31
	220	792	43	35	31	28	35
	360	1296	45	37	33	29	38
250-D16	30	108	33	28	24	22	21
	80	288	39	33	30	28	28
	120	432	42	36	33	30	31
	195	702	47	42	38	36	38

- ① TVLK
- ② TVLK with circular silencer CAK, insulation thickness 50 mm, length 500 mm
- ③ TVLK with circular silencer CAK, insulation thickness 50 mm, length 1000 mm
- ④ TVLK with circular silencer CAK, insulation thickness 50 mm, length 1500 mm

Quick sizing: Sound pressure level at differential pressure 150 Pa TVLK with Universal controller

Nominal size	\dot{V}		Air-regenerated noise				Case-radiated noise
			①	②	③	④	①
	l/s	m ³ /h	L _{PA}	L _{PA1}			L _{PA2}
							dB(A)
250-100	65	234	41	34	30	27	27
	180	648	46	38	34	31	35
	290	1044	47	39	35	31	40
	360	1296	48	39	35	32	42
250-160	35	126	38	33	29	26	23
	100	360	42	36	32	29	30
	160	576	43	37	34	32	32
	195	702	49	42	38	35	40
250-D10	65	234	37	30	26	22	25
	180	648	43	35	31	28	33
	290	1044	44	36	32	29	36
	360	1296	48	39	35	32	42
250-D16	35	126	34	29	25	23	22
	100	360	41	35	32	29	30
	160	576	43	37	34	32	32
	195	702	47	42	38	36	38

- ① TVLK
- ② TVLK with circular silencer CAK, insulation thickness 50 mm, length 500 mm
- ③ TVLK with circular silencer CAK, insulation thickness 50 mm, length 1000 mm
- ④ TVLK with circular silencer CAK, insulation thickness 50 mm, length 1500 mm

Description

- VAV terminal unit for the control of variable air volume flow rates
- Spigot connection



VAV terminal unit, variant TVLK, with connecting circular spigot

Dimensions

Dimensional drawing of TVLK

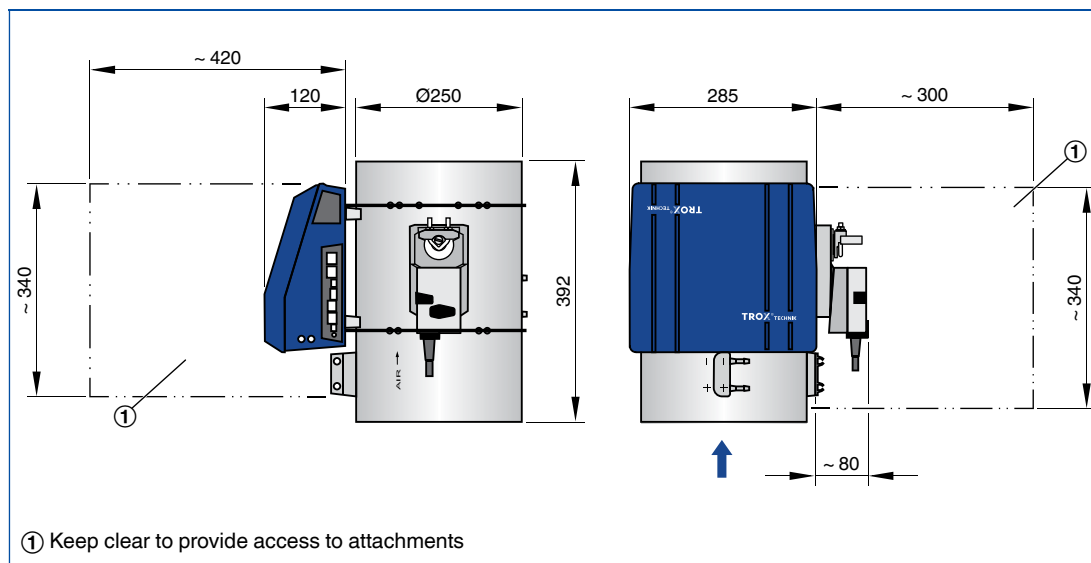

Weight

Nominal size	m
	kg
250	5.1

Description



VAV terminal unit, variant TVLK, with flange

- VAV terminal unit for the control of variable air volume flow rates
- With flanges to make detachable connections to the ductwork

Dimensions

Dimensional drawing of TVLK-FL

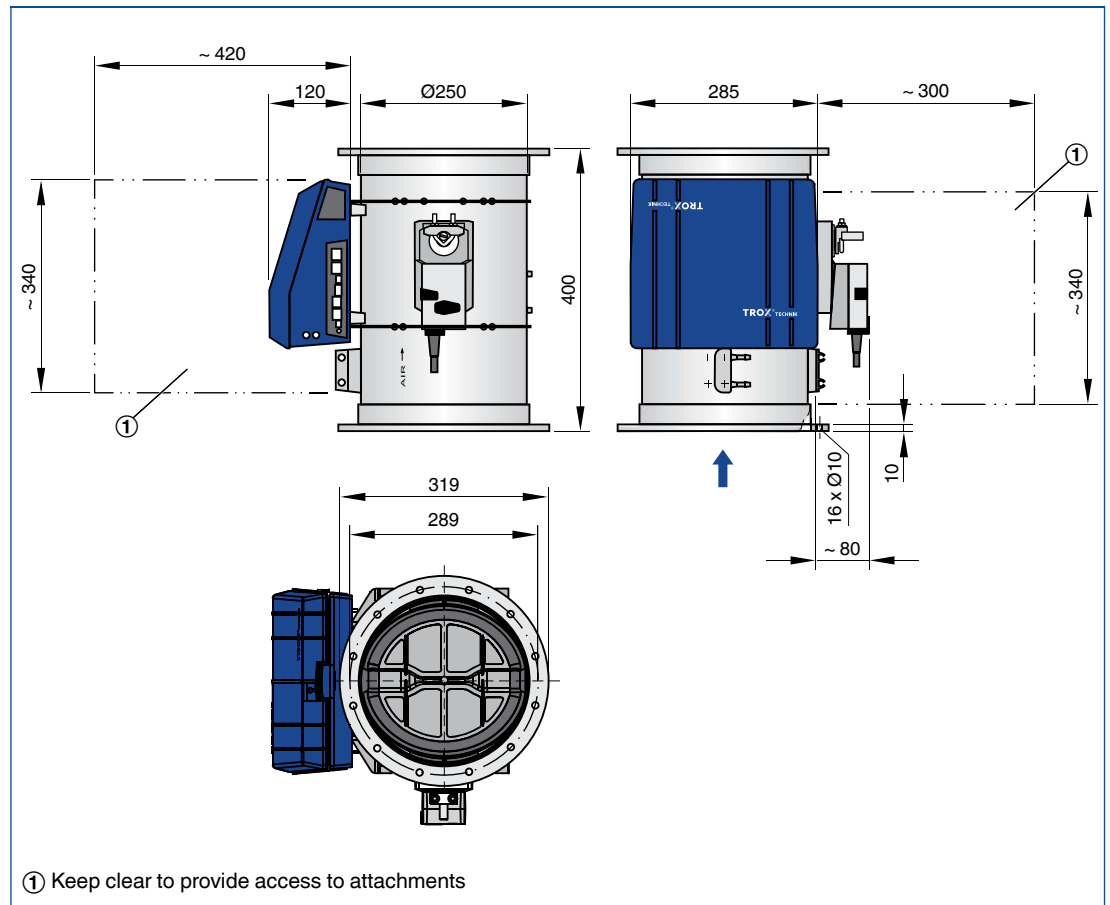

Weight

Nominal size	m
	kg
250	5.7

Standard text

This specification text describes just one variant of the product that applies to many applications. Texts for other variants can be generated with our Easy Product Finder design programme.

Circular VAV terminal units made of flame-resistant plastic, for variable air volume systems and fume cupboards. Suitable for the control of extract air containing aggressive media since all components coming into contact with the airflow are made of plastic (no interior metal parts). Ready-to-commission unit consists of the mechanical parts and the electronic control components. Each unit contains an averaging differential pressure sensor with a bluff body or a Venturi nozzle for volume flow rate measurement, and a damper blade. Factory-assembled control components complete with wiring and tubing. Differential pressure sensor with 3 mm measuring holes (resistant to dust and pollution). Spigot connection, suitable for ducts according to DIN 8077.

Position of the damper blade indicated externally at shaft extension.
Closed blade air leakage to EN 1751, class 4.
Casing air leakage to EN 1751, class C.

Special features

- High control accuracy even in case of unfavourable upstream conditions
- Integral slide-out differential pressure sensor with 3 mm measurement holes (resistant to dust and pollution)
- No metal parts come into contact with the airflow
- Factory set-up or programming and aerodynamic function testing
- Volume flow rate can be measured and subsequently adjusted on site; additional adjustment tool or configuration software may be necessary

Materials and surface

- Casing and damper blade made of flame-resistant polypropylene (PP), flammability to UL 94, V-0
- Differential pressure sensor (with bluff body, or Venturi nozzle) and plain bearing made of polypropylene (PP)
- Damper blade seal made of thermoplastic elastomers (TPE)

Technical data

- Nominal sizes: 250 mm
- Volume flow rate range: 30 to 360 l/s or 108 to 1296 m³/h
- Volume flow rate control range: approx. 15 to 100 % of the nominal volume flow rate
- Differential pressure: 5 – 1000 Pa

Attachments

Variable volume flow control with electronic EASYLAB controller for fume cupboards.

- Supply voltage 24 V AC
- Fast and stable control
- Static differential pressure measurement
- Fast-running actuator
- Easy commissioning due to plug and play communication system
- Controller is a modular system and can be expanded
- Volume flow rate monitoring

Selection data

- \dot{V} _____ [m³/h]
- Δp_{st} _____ [Pa]
- L_{PA} Air-regenerated noise _____ [dB(A)]
- L_{PA} Case-radiated noise _____ [dB(A)]

Order options

TVR with EASYLAB

1 Type

TVLK VAV terminal unit made of plastic

2 Flange

No entry: none

FL Flanges on both ends

3 Nominal size

- 250 – 100** Bluff body 100
- 250 – 160** Bluff body 160
- 250 – D10** Venturi nozzle D10
- 250 – D16** Venturi nozzle D16

4 Accessories

No entry: none

GK Matching flanges for both ends

5 Control component

ELAB EASYLAB controller TCU3 with fast-running actuator

6 Equipment function – fume cupboard control

With face velocity transducer

FH-VS Face velocity control

With sash distance sensor

- FH-DS** Linear control strategy
- FH-DV** Safety-optimised control strategy

With switching steps for on-site switch contacts

- FH-2P** 2 switching steps
- FH-3P** 3 switching steps

Without signalling

FH-F Volume flow rate constant value

7 Expansion modules

Option 1: Supply voltage

No entry: 24 V AC

- T** EM-TRF for 230 V AC
- U** EM-TRF-USV for 230 V AC, provides uninterruptible power supply (UPS)

Option 2: Communications interface

No entry: none

- L** EM-LON for LonWorks FTT-10A
- B** EM-BAC-MOD-01 for BACnet MS/TP
- M** EM-BAC-MOD-01 for Modbus RTU

Option 3: Automatic zero point correction

No entry: none

- Z** EM-AUTOZERO Solenoid valve for automatic zero point correction

Option 4: Lighting

No entry: none

- S** EM-LIGHT Socket for switching the lighting on/off using the control panel (only with EM-TRF or EM-TRF-USV)

8 Operating values [m³/h or l/s]

Depending on the equipment function

- FH-VS**: $\dot{V}_{\min} - \dot{V}_{\max}$
- FH-DS**: $\dot{V}_{\min} - \dot{V}_{\max}$
- FH-DV**: $\dot{V}_{\min} - \dot{V}_{\max}$
- FH-2P**: \dot{V}_1 / \dot{V}_2
- FH-3P**: $\dot{V}_1 / \dot{V}_2 / \dot{V}_3$
- FH-F**: \dot{V}_1

Useful additions

Control panel for fume cupboard controllers, for displaying the functions of the control system according to EN 14175

- BE-SEG-**** with 2-character display
- BE-LCD-**** with 40-character display

Order options

TVLK with TCU-LON II

1 Type

TVLK VAV terminal unit made of plastic

2 Flange

No entry: none

FL Flanges on both ends

3 Nominal size [mm]

- 250 – 100** Bluff body 100
- 250 – 160** Bluff body 160
- 250 – D10** Venturi nozzle D10
- 250 – D16** Venturi nozzle D16

4 Accessories

No entry: none

GK Matching flanges for both ends

5 Control components

Example

- TMA** TCU-LON-II with fast-running actuator
- TMB** TCU-LON-II with fast-running actuator (brushless motor)
- BB3** Universal controller
- BPG** Universal controller with fast-running actuator

6 Equipment function

- FH** Fume cupboard (only TM*)
- RE** Extract air controller (only TM*)
- E2** Single room controller (only B**)
- F2** Constant volume flow controller (only B**)

7 Operating values [m³/h or l/s]

Depending on the equipment function

- FH**: $\dot{V}_{\min} - \dot{V}_{\max}$
- RE**: $\dot{V}_{\text{day}} / \dot{V}_{\text{night}} / \dot{V}_{\text{constant}}$
- E2**: $\dot{V}_{\min} - \dot{V}_{\max}$
- F2**: $\dot{V}_{\text{constant}}$

Useful additions

Control panel for fume cupboard controller for displaying the functions of the control system according to EN 14175

BE-TCU-LON-II 40-character display

1

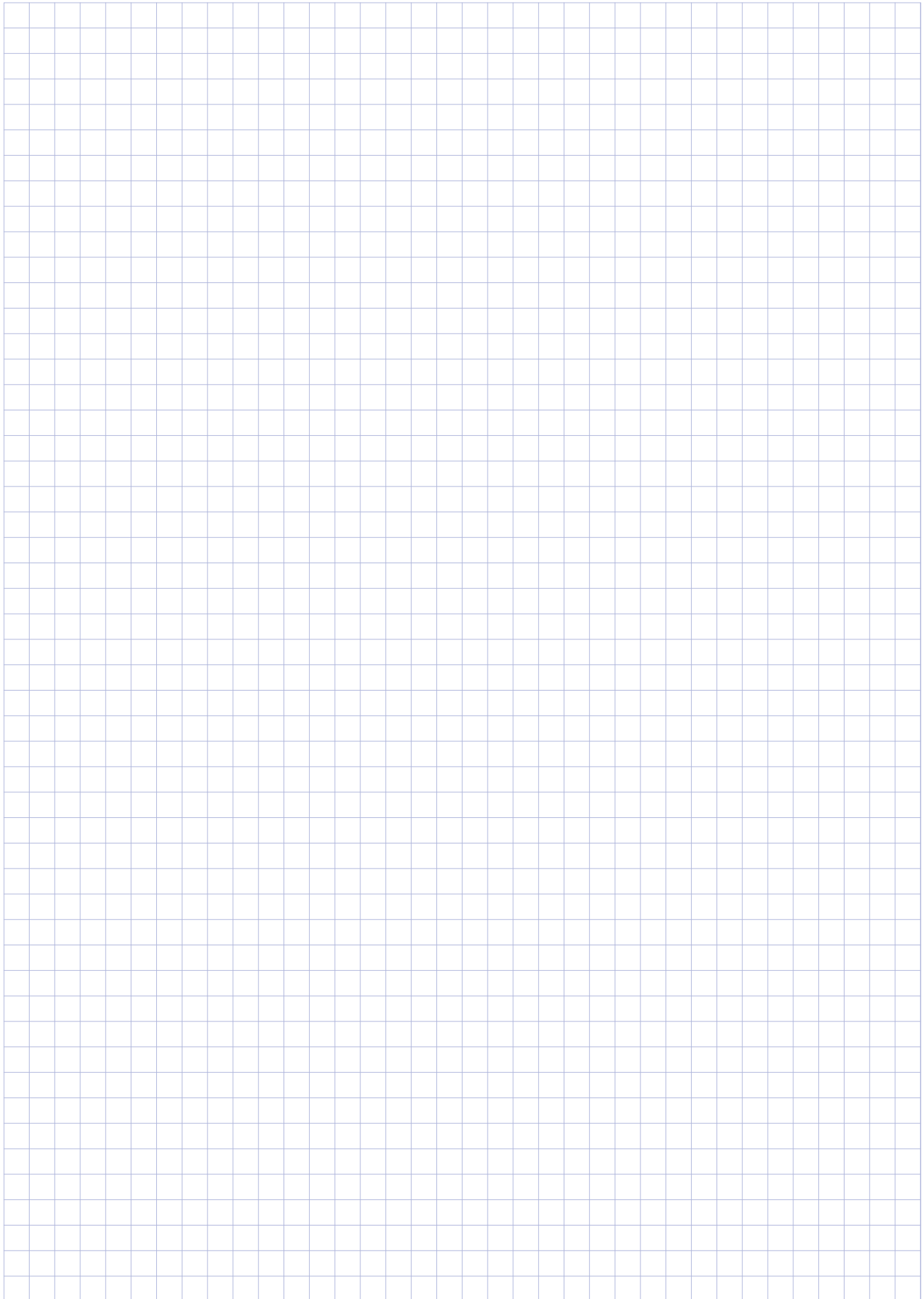

Secondary silencers for VAV terminal units Type CAK



For the reduction of noise in plastic circular ducts, suitable for all circular VAV terminal units and CAV controllers, plastic construction for contaminated air

Plastic circular silencers for the reduction of noise in the circular ducts of extract air systems for aggressive media

- Absorption material is non-combustible mineral wool with RAL quality mark, biosoluble and hence hygienically safe according to the German TRGS 905 (Technical Rules for Hazardous Substances) and EU directive 97/69/EG (Hazardous Substances) and EU directive 97/69/EG
- Mineral wool faced with non-woven glass fibre as protection against erosion due to airflow velocities up to 20 m/s
- Casing and perforated inner duct are flame-resistant polypropylene (PPs) to DIN 4102, building class B1
- Variant with spigot connection suitable for circular ducts according to DIN 8077 or DIN 8078
- Insertion loss tested to EN ISO 7235
- Casing air leakage to EN 15727, class D

Optional equipment and accessories

- With flanges on both ends

Type		Page
CAK	General information	1.2 – 2
	Order code	1.2 – 3
	Dimensions and weight – CAK	1.2 – 4
	Dimensions and weight – CAK/.../VF2	1.2 – 5
	Specification text	1.2 – 6
	Basic information and nomenclature	1.5 – 1

Description



Circular silencer
Type CAK

Application

- Plastic circular silencers Type CAK for the reduction of noise in the circular ducts of air conditioning systems
- Suitable for contaminated air
- For the reduction of air-regenerated noise of air terminal units TVRK and TVLK
- For the reduction of noise from the fan

Variants

- CAK: Circular silencer
- VF2: Circular silencer with flanges on both ends

Nominal sizes

- 125, 160, 200, 250, 315, 400

Accessories

- GZ: Matching flanges for both ends

Special features

- Insertion loss tested to EN ISO 7235
- Absorption material is non-combustible

Parts and characteristics

- Casing
- Perforated inner tube
- Absorption material

Construction features

- Circular casing
- Spigot connection suitable for circular ducts according to DIN 8077 or DIN 8078
- Maximum operating pressure 1000 Pa
- Operating temperature 10 to 100 °C

Materials and surface

- Casing and perforated inner duct are flame-resistant polypropylene (PPs) to DIN 4102, building class B1
- Lining is mineral wool

Mineral wool

- To EN 13501, fire rating class A2, non-combustible
- RAL quality mark RAL-GZ 388
- Biosoluble and hence hygienically safe according to the German TRGS 905 (Technical Rules for Hazardous Substances) and EU directive 97/69/EG
- Faced with non-woven glass fibre as protection against erosion through airflow velocities up to 20 m/s
- Inert to fungal and bacterial growth

Installation and commissioning

- Any installation orientation
- Installation in ducts outside of closed rooms requires sufficient protection against the effects of weather

Standards and guidelines

- Insertion loss tested to EN ISO 7235
- Casing air leakage to EN 15727, class D

Maintenance

- Maintenance-free as construction and materials are not subject to wear

Order code

CAK

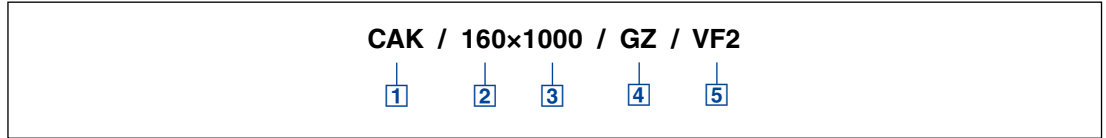

1 Type

CAK Circular silencer

2 Nominal size [mm]

- 125
- 160
- 200
- 250
- 315
- 400

3 Length [mm]

- 500
- 1000
- 1500

4 Matching flange

No entry: none

GZ on both ends (only VF2)

5 Type of connection

No entry: spigot

VF2 Flanges on both ends

Order example

CAK/200x1000

Nominal size200 mm
Length..... 1000 mm
Type of connection..... spigot

Application

- Circular silencer for the reduction of noise
- Spigot connection

Dimensions

Dimensional drawing of CAK

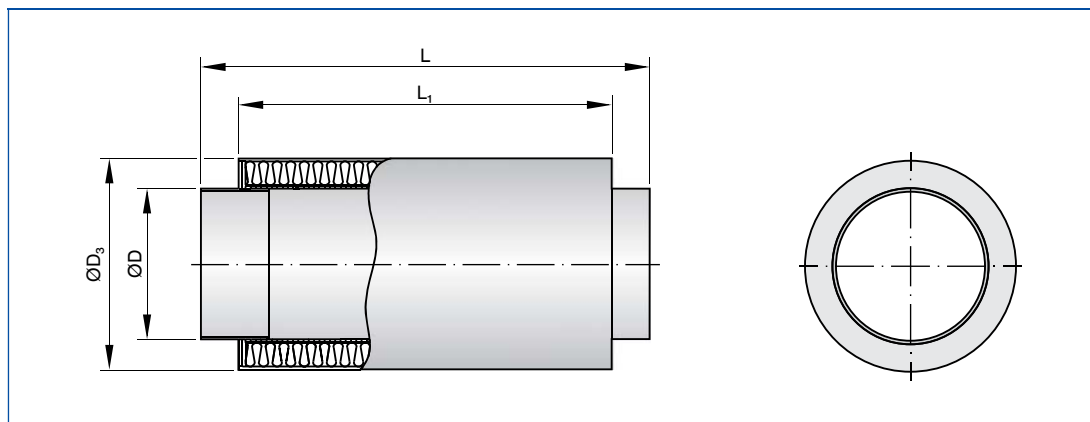

Dimensions

Nominal size	ØD	ØD ₃
	mm	mm
125	125	225
160	160	250
200	200	280
250	250	355
315	315	415
400	400	500

Dimensions

Nominal length	L	L ₁
	mm	mm
500	595	495
1000	1095	995
1500	1595	1495

Weight

Nominal size	500	1000	1500
	m	m	m
	kg	kg	kg
125	2.2	4.1	5.9
160	2.6	4.7	6.8
200	3.2	5.8	8.5
250	4.3	7.6	10.9
315	4.6	8.6	12.5
400	5.2	9.3	13.4

Application

- Circular silencer for the reduction of noise
- With flanges to make detachable connections to the ductwork

Dimensions

Dimensional drawing of CAK/.../VF2

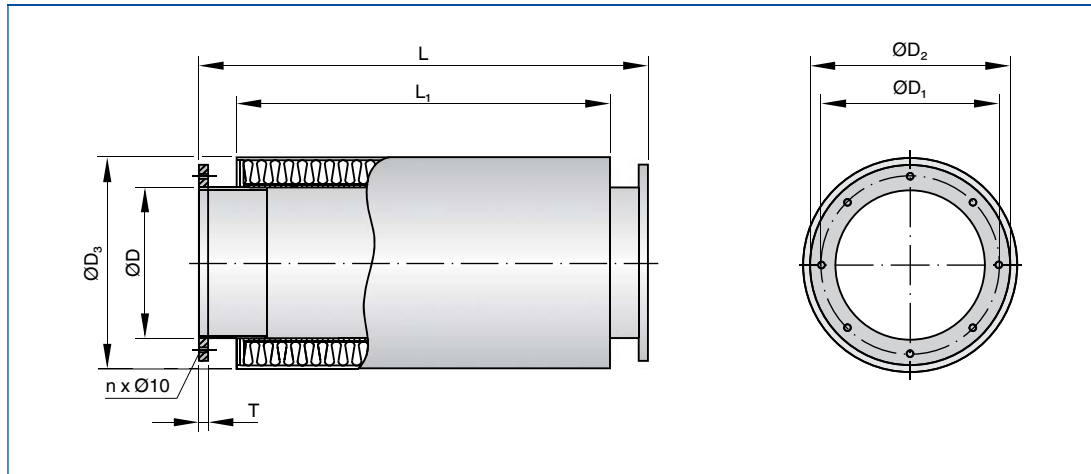

Dimensions

Nominal size	ØD	ØD ₃	ØD ₁	ØD ₂	n	T
	mm	mm	mm	mm		mm
125	125	225	165	185	8	8
160	160	250	200	230	8	8
200	200	280	240	270	8	8
250	250	355	290	320	12	8
315	315	415	350	395	12	10
400	400	500	445	475	16	10

Dimensions

Nominal length	L	L ₁
	mm	mm
500	595	495
1000	1095	995
1500	1595	1495

Weight

Nominal size	500	1000	1500
	m	m	m
	kg	kg	kg
125	2.5	4.4	6.2
160	3.0	5.1	7.2
200	3.6	6.2	8.9
250	4.9	8.2	11.5
315	5.3	9.3	13.7
400	6.8	10.9	15.0

Description

1 This specification text describes just one variant of the product that applies to many applications. Texts for other variants can be generated with our Easy Product Finder design programme.

Plastic circular silencers for use in extract air systems subject to aggressive media; they reduce the air-regenerated noise in plastic ducts (absorption principle).
Insertion loss tested to EN ISO 7235.
Absorption material is mineral wool with RAL quality mark RAL-GZ 388.
Spigot connection, suitable for ducts according to DIN 8077.
Casing air leakage to EN 15727, class D.

Special features

- Insertion loss tested to EN ISO 7235
- Absorption material is non-combustible

Materials and surface

- Casing and perforated inner duct are flame-resistant polypropylene (PPs) to DIN 4102, building class B1
- Lining is mineral wool

Mineral wool

- To EN 13501, fire rating class A2, non-combustible
- RAL quality mark RAL-GZ 388
- Biosoluble and hence hygienically safe according to the German TRGS 905 (Technical Rules for Hazardous Substances) and EU directive 97/69/EG
- Faced with non-woven glass fibre as protection against erosion through airflow velocities up to 20 m/s
- Inert to fungal and bacterial growth

Technical data

- Nominal sizes: 125 – 400 mm
- Operating pressure: 1000 Pa max.
- Operating temperature: 100 °C max.

Order options

1 Type

CAK Circular silencer

2 Nominal size [mm]

- 125
- 160
- 200
- 250
- 315
- 400

3 Length [mm]

- 500
- 1000
- 1500

4 Matching flange

No entry: none

- GZ** on both ends (only VF2)

5 Type of connection

No entry: spigot

- VF2** Flanges on both ends

Variable volume flow control 1

LABCONTROL

Basic information and nomenclature



- Product selection
- Principal dimensions
- Nomenclature
- Correction values for system attenuation
- Measurements
- Sizing and sizing example
- Function
- Operating modes

Variable volume flow control – VARYCONTROL

Basic information and nomenclature

Product selection

	Type											
	LVC-LowVelocity	TVR	TVJ	TVT	TZ-Silenzio	TA-Silenzio	TVZ	TVA	TVM	TVRK	TVLK	TVR-Ex
Type of system												
Supply air	●	●	●	●	●		●			●		●
Extract air	●	●	●	●		●		●		●	●	●
Dual duct (supply air)									●			
Duct connection, fan end												
Circular	●	●					●	●	●	●	●	●
Rectangular			●	●	●	●						
Volume flow rate range												
Up to [m³/h]	1080	6050	36360	36360	3025	3025	6050	6050	6050	6050	1295	6050
Up to [l/s]	300	1680	10100	10100	840	840	1680	1680	1680	1680	360	1680
Air quality												
Filtered	●	●	●	●	●	●	●		●	●	●	●
Office extract air	●	●	●	●		●		●		●	●	●
Polluted		○	○	○		○		○		●	●	○
Contaminated										●	●	
Control function												
Variable	●	●	●	●	●	●	●	●	●	●	●	●
Constant	●	●	●	●	●	●	●	●	●	●	●	●
Min/Max	●	●	●	●	●	●	●	●	●	●	●	●
Differential pressure control		○	○	○	○	○	○	○		○		○
Master/Slave	●	●	●	●	●	●	●	●	Master	●	●	●
Shut-off												
Leakage			●									
Low leakage	●	●		●	●	●	●	●	●	●	●	●
Acoustic requirements												
High < 40 dB (A)			○	○	●	●	●	●	○			
Low < 50 dB (A)	●	●	●	●	●	●	●	●	●	●	●	●
Other functions												
Volume flow rate measurement	●	●	●	●	●	●	●	●	●	●	●	●
Special areas												
Potentially explosive atmospheres												●
Laboratories, clean rooms, operation theatres (EASYPOL, TCU-LON II)		●	●	●			●	●		●	●	

● Possible

○ Possible under certain conditions: Robust unit variant and/or specific control component or useful additional product

□ Not possible

Variable volume flow control – VARYCONTROL

Basic information and nomenclature

Principal dimensions

$\varnothing D$ [mm]

VAV terminal units made of stainless steel:
Outside diameter of the connecting spigot
VAV terminal units made of plastic: Inside diameter of the connecting spigot

$\varnothing D_1$ [mm]

Pitch circle diameter of flanges

$\varnothing D_2$ [mm]

Outside diameter of flanges

$\varnothing D_4$ [mm]

Inside diameter of the screw holes of flanges

L [mm]

Length of unit including connecting spigot

L_1 [mm]

Length of casing or acoustic cladding

W [mm]

Width of the duct

B_1 [mm]

Screw hole pitch of air duct profile (horizontal)

B_2 [mm]

Outside dimension of air duct profile (width)

B_3 [mm]

Width of device

H [mm]

Duct height

H_1 [mm]

Screw hole pitch of air duct profile (vertical)

H_2 [mm]

Outside dimension of air duct profile (height)

H_3 [mm]

Unit height

n []

Number of flange screw holes

T [mm]

Flange thickness

m [kg]

Unit weight including the minimum required attachments (e.g. Compact controller)

Nomenclature

f_m [Hz]

Octave band centre frequency

L_{PA} [dB(A)]

A-weighted sound pressure level of air-regenerated noise of the VAV terminal unit, system attenuation taken into account

L_{PA1} [dB(A)]

A-weighted sound pressure level of air-regenerated noise of the VAV terminal unit with secondary silencer, system attenuation taken into account

L_{PA2} [dB(A)]

A-weighted sound pressure level of case-regenerated noise of the VAV terminal unit, system attenuation taken into account

L_{PA3} [dB(A)]

A-weighted sound pressure level of case-regenerated noise of the VAV terminal unit with acoustic cladding, system attenuation taken into account

Definition of noise

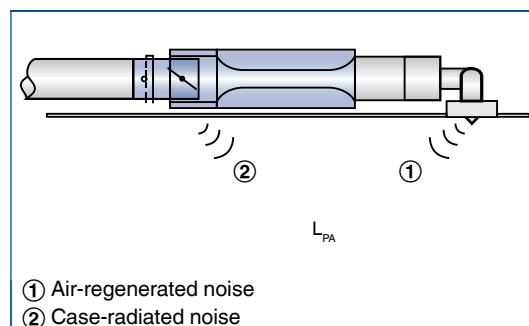

\dot{V}_{nom} [m³/h] and [l/s]

Nominal volume flow rate (100 %)

\dot{V} [m³/h] and [l/s]

Volume flow rate

$\Delta\dot{V}$ [± %]

Volume flow rate tolerance from setpoint value

$\Delta\dot{V}_{warm}$ [± %]

Volume flow rate tolerance for the warm air flow of dual duct terminal units

ΔP_{st} [Pa]

Static differential pressure

$\Delta P_{st min}$ [Pa]

Static differential pressure, minimum

Static differential pressure

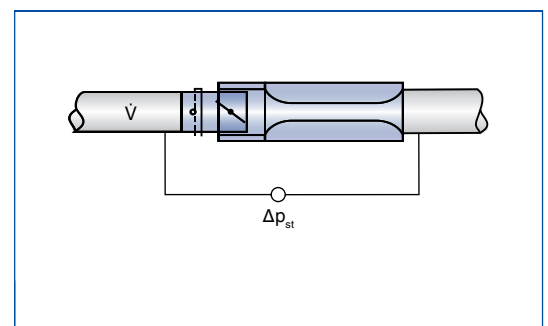

Variable volume flow control – VARYCONTROL

Basic information and nomenclature

1

The quick sizing tables show the sound pressure levels that can be expected in a room both for the air-regenerated noise and for the case-radiated noise. The sound pressure level in a room results from the sound power level of the products – for a given volume flow rate and differential pressure – and the attenuation and insulation on site. This is why generally accepted attenuation and insulation values have been taken into account for the tables.

The distribution of air across the ductwork, changes of direction, end reflection, and room attenuation all affect the sound pressure level of the air-regenerated noise. Ceiling insulation and room attenuation influence the sound pressure level of the case-radiated noise.

Reducing the sound pressure level of the air-regenerated noise

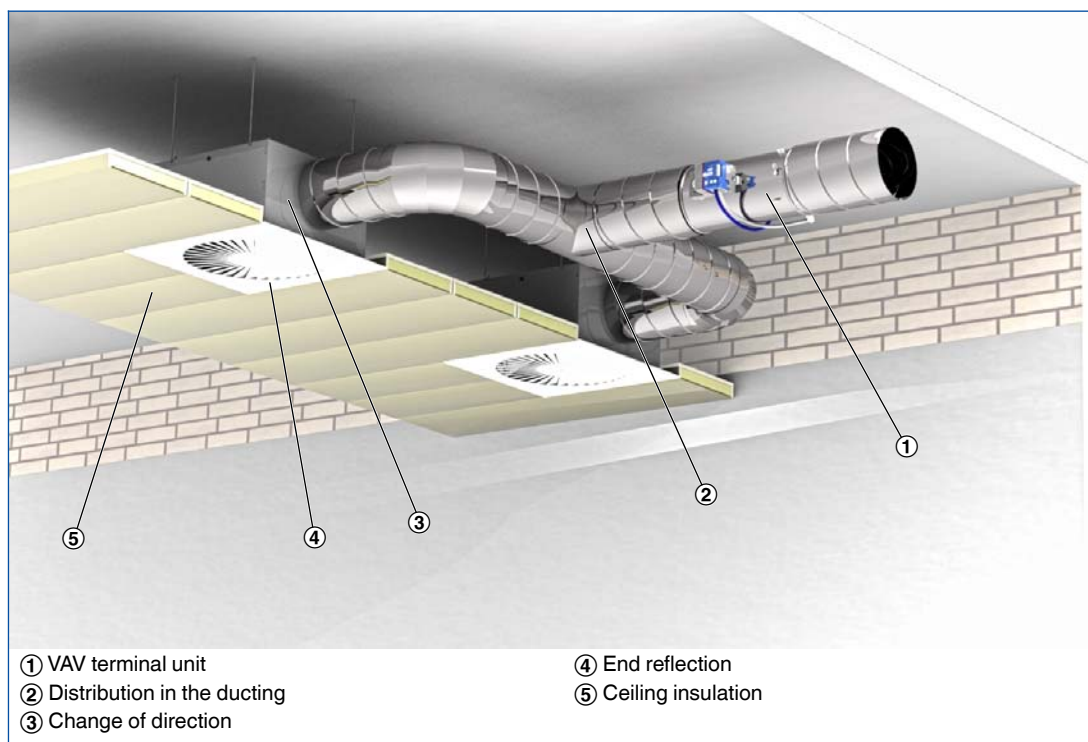

- ① VAV terminal unit
- ② Distribution in the ducting
- ③ Change of direction
- ④ End reflection
- ⑤ Ceiling insulation

Correction values for acoustic quick sizing

The correction values for the distribution in the ducting are based on the number of diffusers assigned to any one CAV controller. If there is just one diffuser (assumption: 140 l/s or 500 m³/h), no correction is necessary.

Octave correction for the distribution in the ducting, used to calculate the air-regenerated noise

\dot{V} [m ³ /h]	500	1000	1500	2000	2500	3000	4000	5000	6000
[l/s]	140	280	420	550	700	840	1100	1400	1700
[dB]	0	3	5	6	7	8	9	10	11

One change of direction, e.g. at the horizontal connection of the diffuser plenum box, has been taken into consideration for the system attenuation values. Vertical connection of the plenum box does not result in a system attenuation. Additional bends result in lower sound pressure levels.

System attenuation per octave to VDI 2081 for the calculation of the air-regenerated noise

Centre frequency [Hz]	63	125	250	500	1000	2000	4000	8000
	ΔL							
	dB	dB	dB	dB	dB	dB	dB	dB
Change of direction	0	0	1	2	3	3	3	3
End reflection	10	5	2	0	0	0	0	0
Room attenuation	5	5	5	5	5	5	5	5

Octave correction for the calculation of case-radiated noise

Centre frequency [Hz]	63	125	250	500	1000	2000	4000	8000
	ΔL							
	dB	dB	dB	dB	dB	dB	dB	dB
Ceiling insulation	4	4	4	4	4	4	4	4
Room attenuation	5	5	5	5	5	5	5	5

Variable volume flow control – VARYCONTROL

Basic information and nomenclature

Measurements

The acoustic data for the air-regenerated noise and case-radiated noise are determined according to EN ISO 5135. All measurements are carried out to EN ISO 3741 in a reverberation chamber.

Measuring the air-regenerated noise

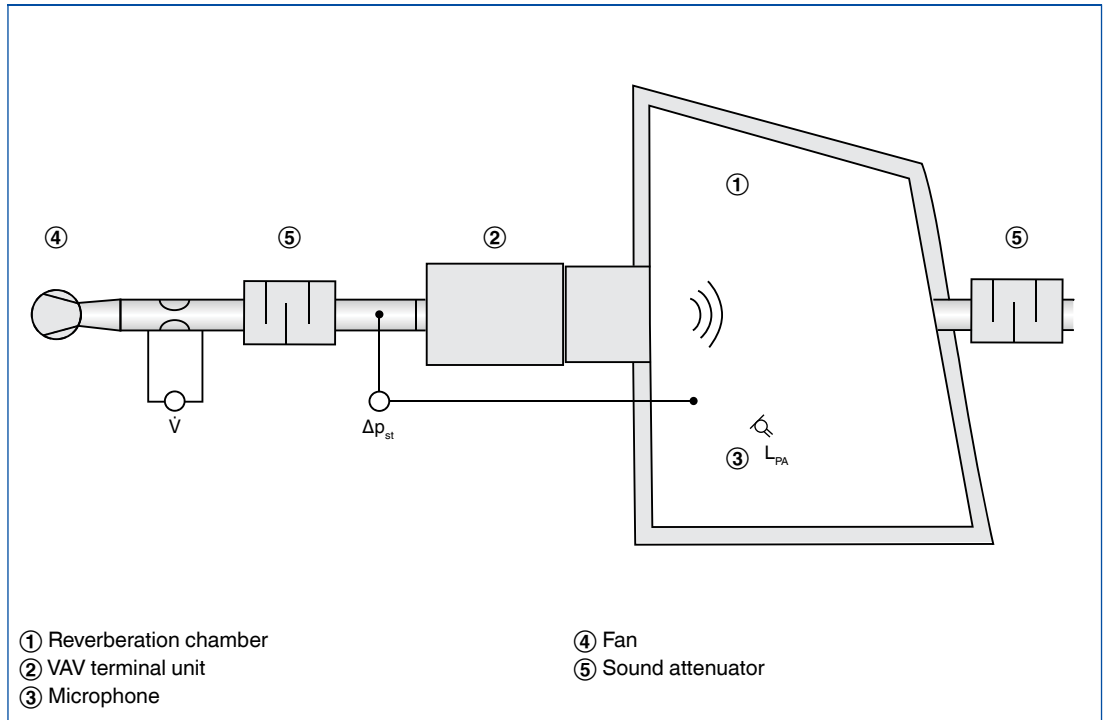

Measuring the case-radiated noise

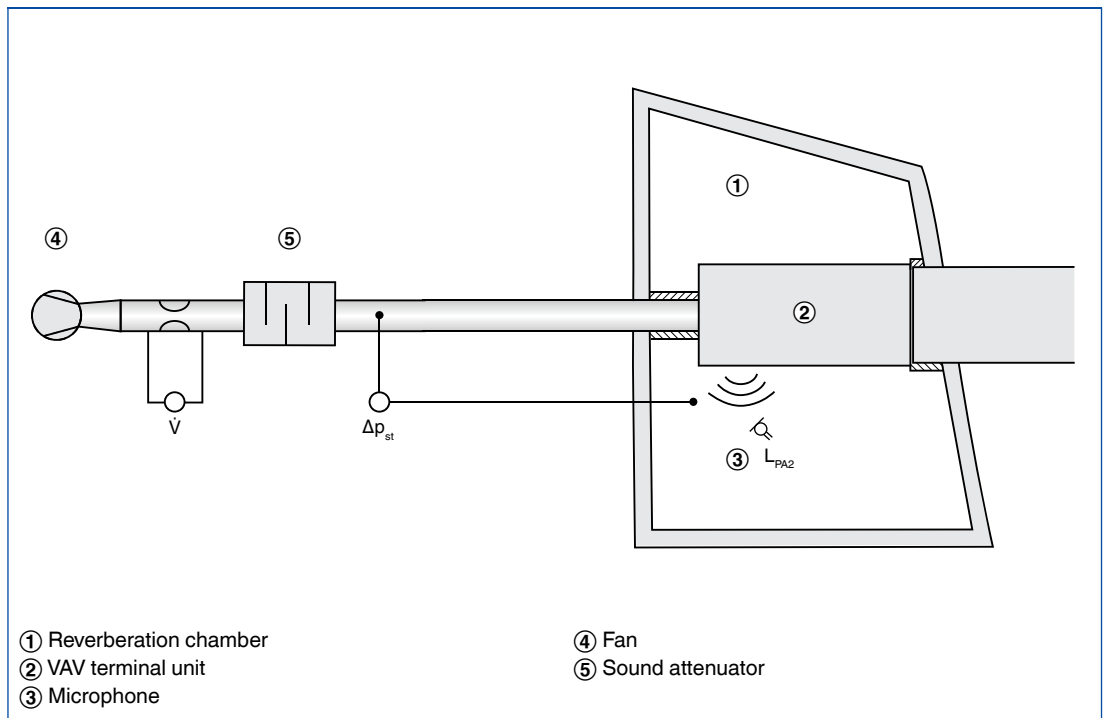

Variable volume flow control – VARYCONTROL

Basic information and nomenclature

1 Sizing with the help of this catalogue

This catalogue provides convenient quick sizing tables for VAV terminal units. The sound pressure levels for air-regenerated noise and for case-radiated noise are provided for all nominal sizes. In addition, generally accepted attenuation and insulation values have been taken

into account.

Sizing data for other volume flow rates and differential pressures can be determined quickly and precisely using the Easy Product Finder design programme.

Sizing example

Given data

$V_{\max} = 280 \text{ l/s}$ (1010 m³/h)
 $\Delta p_{\text{st}} = 150 \text{ Pa}$
 Required sound pressure level in the room
 30 dB(A)

Sizing

TVZ-D/200
 Air-regenerated noise $L_{\text{PA}} = 23 \text{ dB(A)}$
 Case-radiated noise $L_{\text{PA}} = 24 \text{ dB(A)}$

Sound pressure level in the room = 27 dB(A)
 (logarithmic addition since the terminal unit is installed in the suspended ceiling of the room)

Easy Product Finder



The Easy Product Finder allows you to size products using your specific data.

You will find the Easy Product Finder on our website.

The screenshot shows the 'Berechnung' (Calculation) tab of the Easy Product Finder software. It displays various input parameters and the resulting acoustic data for a TVZ-D/200 terminal unit.

Bestellschlüssel (Anklicken zum Ändern): TVZ / 200 / BCO / E0 / 144-1010 m³/h

Regelkomponente: nicht belastet (verzinktes Stahlblech)

Betriebsmedium: elektrisch

Betriebsfunktion: stetig / analoge Ansteuerung VAV

Ansteuerung: 0-10 VDC

Schnelllaufend: ohne

Sicherheitsfunktion: ohne

Regelung: BCO(VAV-Compact(0-10VDC))LMV-D2MP

Volumenstrom: variabel / konstant

$V_{\min} \leq$ [] m³/h (54...6048)

$V_{\max} \leq$ 1.010 m³/h (162...6048)

Volumenstrom-Regelgerät: Filter

Dämmschale: ohne Dämmschale

Schalldämpfer: ohne und mit

Serie	Abmessung	V_{\min} [m ³ /h]		V_{\max} [m ³ /h]		L_p [dB(A)]	
		von	bis	von	bis	Strömungsgerä...	Abstrahlgeräusch
TVZ	200	144	1458	432	1458	23	31
TVZ+TS	200	144	1458	432	1458	18	31
TVZ	250	216	2214	666	2214	18	26
TVZ+TS	250	216	2214	666	2214	<15	26

Akustische Eingabedaten:

L_p Strömung \leq 23 dB(A)

L_p Abstrahlung \leq 31 dB(A)

Δp_{st} 150 Pa (100...1000)

Akustische Ergebnisse:

Bar chart showing $L_{w, \text{str}}$ [dB] vs f [Hz]. The chart shows noise levels for different frequency bands: 63, 125, 250, 500, 1K, 2K, 4K, 8K Hz. The highest noise level is at 63 Hz, around 48 dB.

Variable volume flow control – VARYCONTROL

Basic information and nomenclature

Function

Volume flow control

The volume flow rate is controlled in a closed loop. The controller receives from the transducer the actual value that results from the effective pressure. For most applications, the setpoint value comes from a room temperature controller. The controller compares the actual value with the setpoint value and alters the command signal of the actuator if there is a difference between the two values.

Correction of duct pressure changes

The controller detects and corrects changes of the duct pressure that may occur, for example, due to volume flow rate changes from other units. Pressure changes will therefore not affect the room temperature.

Variable volume flow control

If the input signal is changed, the controller adjusts the volume flow rate to the new setpoint. The variable volume flow rate range is limited, i.e. there is a minimum value and a maximum value. This control strategy can be overridden, e.g. by shutting off the duct.

Control loop

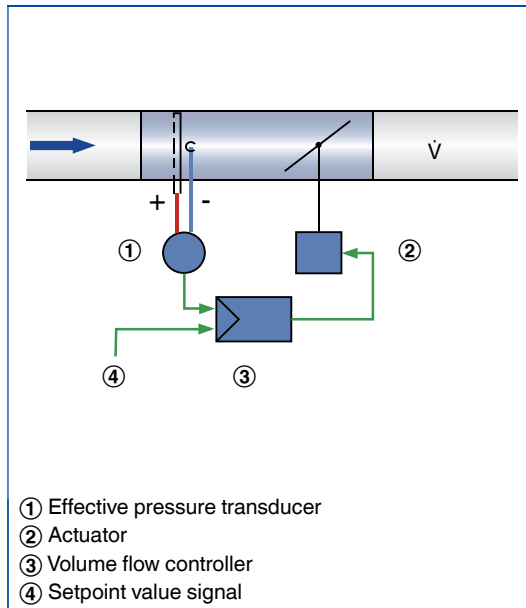

Control diagram

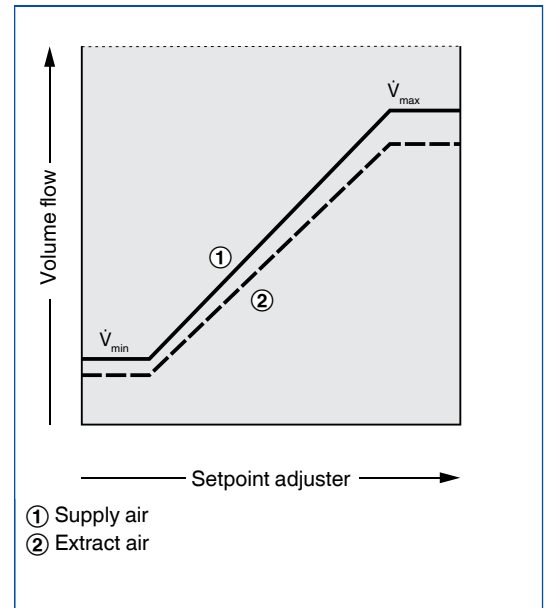

Operating modes

Single operation

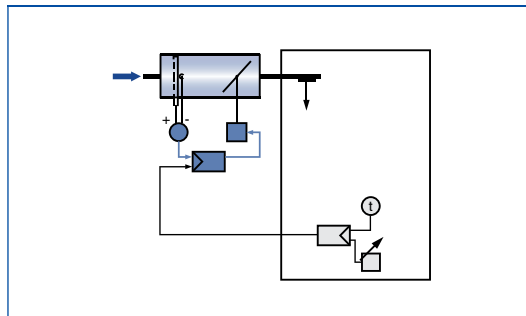

Master slave operation (master)

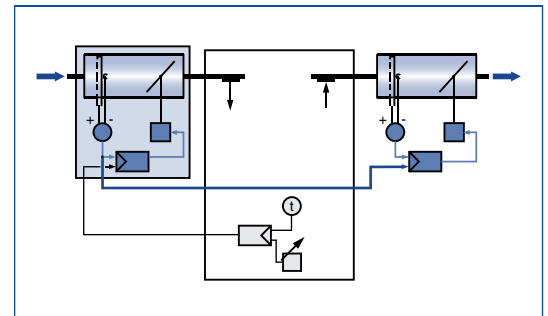

Constant value

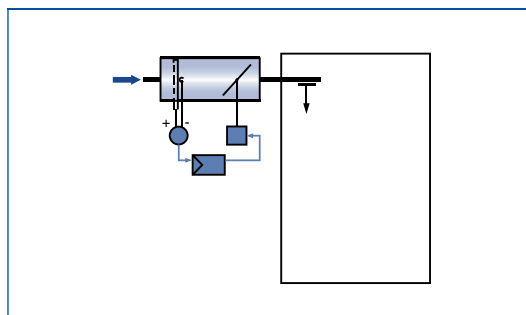

Master slave operation (slave)

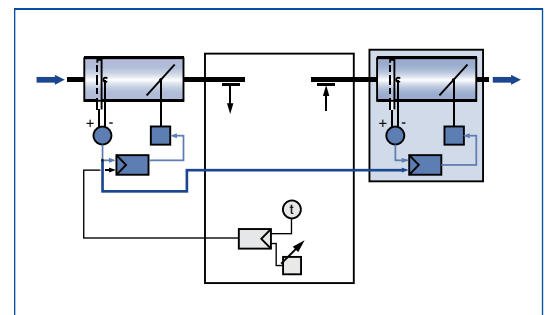

2 Air management control systems

EASYLAB and LABCONTROL are components for tailor-made solutions aimed at the safe and energy-efficient air management in critical areas such as laboratories, clean rooms, and hospitals. Because of their quick-response control loops they can be used for fume cupboards and for room pressure control. Complex room balancing functions and room monitoring functions are likewise possible.



2.1 Controller

Type

Page



EASYLAB controllers for the most demanding control engineering tasks

EASYLAB TCU3 2.1 – 1



Adapter module for the expansion of the EASYLAB system

TAM 2.1 – 27



LON controller for the most demanding control engineering tasks

TCU-LON-II 2.1 – 39

2.2 Monitoring systems



For the monitoring of volume flows

TFM-1 2.2 – 1



For the monitoring of differential pressure, volume flow rate or face velocity

TFM-2/TPM 2.2 – 7

2.3 Expansion modules



LonWorks interface for EASYLAB controllers and adapter modules

EM-LON 2.3 – 1



BACnet and Modbus interface for EASYLAB controllers and adapter modules

EM-BAC-MOD 2.3 – 19

2.3 Expansion modules	Type	Page
	For the connection of EASYLAB to the 230 V mains	EM-TRF 2.3 – 39
	For the connection of EASYLAB to the 230 V mains and for uninterruptible power supply	EM-TRF-USV 2.3 – 43
	Automatic zero point correction for EASYLAB	EM-AUTOZERO 2.3 – 49
	For the simple connection of lighting to an EASYLAB fume cupboard controller	EM-LIGHT 2.3 – 53
2.4 Sensor systems		
	For fume cupboard controllers EASYLAB and TCU-LON-II	VS-TRD 2.4 – 1
	For EASYLAB fume cupboard controllers	DS-TRD-01 2.4 – 7
	For the differential pressure recording and control in combination with EASYLAB and TCU-LON-II	Differential pressure transducer 2.4 – 13

2.5 Control panels **Type** **Page**



For EASYLAB fume cupboard controllers or room controllers, with text display

BE-LCD-01

2.5 – 1



For EASYLAB fume cupboard controllers

BE-SEG

2.5 – 9



For fume cupboard controllers TCU-LON-II

BE-TCU-LON-II

2.5 – 17

2.6 Configuration software



TCU-LON-II plug-in: Configuration software for the commissioning and diagnosis of TCU-LON-II

PlugIn TCU-LON-II **2.6 – 1**



For the commissioning and diagnosis of TFM and TPM

MConnect **2.6 – 5**

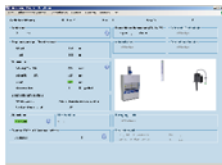

For the commissioning and diagnosis of EASYLAB components

EasyConnect **2.6 – 9**

2.7 Basic information and nomenclature



Air management control systems

2.7 – 1



Plug sockets on the outside



Variant with battery pack



For laboratories



For hospitals



For clean rooms, e.g. in semiconductor manufacturing

Controller

Type EASYLAB TCU3

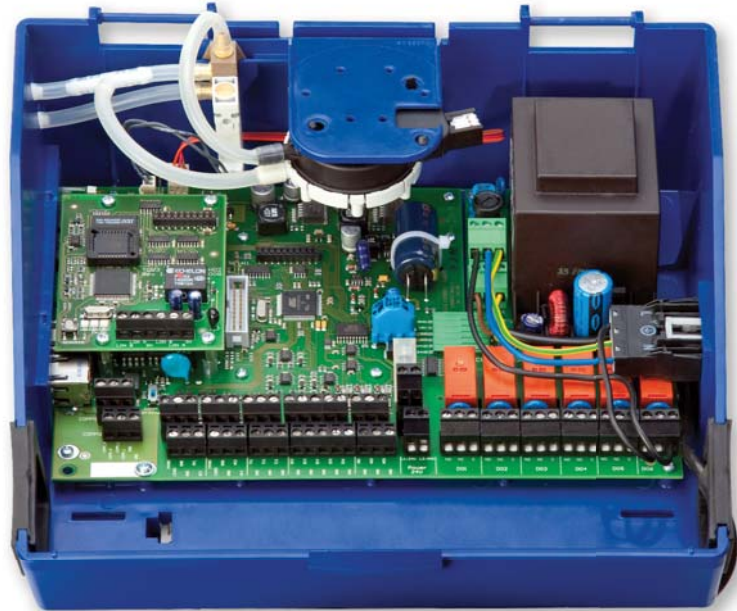

EASYLAB controllers for the most demanding control engineering tasks

Electronic controller that offers plug and play communication for demanding control tasks, yet simple wiring and commissioning

- Maximum control comfort for laboratories, clean rooms, hospital wards, and offices
- Perfect system for complete room solutions from a single source
- Demand-based and quick-response control for fume cupboards, and of supply air, extract air and pressure
- Interactive configuration software with commissioning wizard and Bluetooth adapter
- Plug-in communication cable for easy wiring
- Adaptable control panels and many special functions allow for individual operating modes and control strategies
- Fume cupboard control and monitoring according to EN 14175

Expansion options

- Connection to the mains (230 V)
- Expansion modules with LonWorks, BACnet or Modbus standard interfaces to the central BMS
- Automatic zero point correction for long-term stability and reduced maintenance
- Control panels for fume cupboards and for room control

Type		Page
EASYPAC TCU3	General information	2.1 – 2
	Order code	2.1 – 6
	Equipment functions – Fume cupboard control	2.1 – 9
	Equipment functions – Room control	2.1 – 15
	Room management function	2.1 – 19
	Specification text – Fume cupboard control	2.1 – 22
	Specification text – Room control	2.1 – 24
	Basic information and nomenclature	2.7 – 1

EASYPAC system solution for the control of fume cupboards, extract air, supply air, and pressure

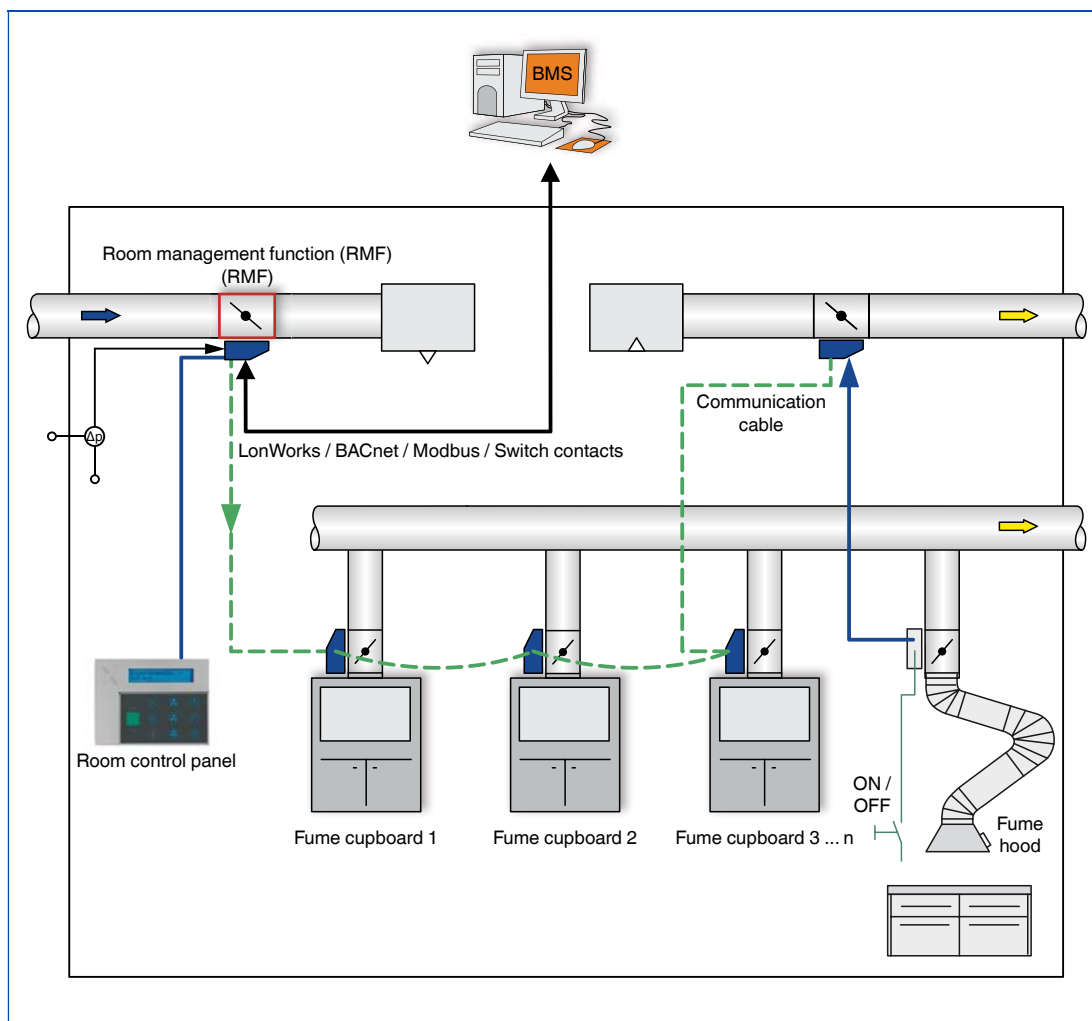

Description



EASYLAB controller
TCU3

Application

- Electronic controller Type EASYLAB TCU3 for the control of volume flow rates in fume cupboards and for the control of supply and extract air in laboratories; can also be used as an attachment for air terminal units
- For use in laboratories, clean rooms in the pharmaceutical and semiconductor industries, operation theatres, intensive care units, and offices with very demanding control requirements
- Fast and stable control of the volume flow rate for fume cupboards, and of room supply air and room extract air
- Fume cupboard control tested to EN 14175, part 6, for fume cupboards of all brands
- Controllers can be used individually or combined with other controllers for a complete room solution
- System solution for the volume flow control in rooms (room balance)
- For extract air led areas such as laboratories
- For supply air led areas such as clean rooms
- Numerous options for the integration of additional volume flows into the room balance
- Room pressure control or duct pressure control as cascade of differential pressure and volume flow rate
- Interface to the central BMS, voltage signals 0 – 10 V or with expansion modules for LonWorks, BACnet, Modbus

Equipment functions

Fume cupboard control

- FH-VS: Face velocity transducer – face velocity control
- FH-DS: Sash distance sensor – linear control strategy
- FH-DV: Sash distance sensor – safety-optimised control strategy
- FH-2P: 2 switching steps for on-site switch contacts
- FH-3P: 3 switching steps for on-site switch contacts
- FH-F: Volume flow rate constant value

Room control

Extract air led system for laboratories

- RS/LAB: Supply air control
- RE/LAB: Extract air control
- PC/LAB: Differential pressure control (supply air)

Supply air led system for clean rooms

- RS/CLR: Supply air control
- RE/CLR: Extract air control
- PC/CLR: Differential pressure control (extract air)

Attachments

Expansion modules are factory mounted or can be fitted at a later stage

- T: EM-TRF, power supply unit for connecting the controller to the 230 V AC mains voltage
- U: EM-TRF-USV, power supply unit for connecting the controller to the 230 V AC mains voltage and to ensure uninterrupted power supply
- Z: EM-AUTOZERO, automatic zero point correction for long-term stable volume flow rate measurement and hence reduced maintenance.
- L: EM-LON, LonWorks FTT-10A interface
- B: EM-BAC-MOD-01, interface configured for BACnet MS/TP
- M: EM-BAC-MOD-01, interface configured for Modbus RTU
- S: EM-LIGHT, wired socket (230 V) for the connection of lighting and for switching the lighting on/off using the control panel

Useful additions

- BE-SEG-**: Control panel for fume cupboard control
- BE-LCD-01: Control panel for fume cupboard control and room control
- TAM: Adapter module as an interface between fume cupboard control and room control, and to the central BMS
- Differential pressure transducers: Static differential pressure transducers for room pressure control or duct pressure control
- EasyConnect: Configuration software for the commissioning and diagnosis of EASYLAB components

Special features

- Plug and play communication system with automatic controller identification, no component addressing required
- Modular system for functional expansion
- Plug sockets and status displays on the outside of the controller casing
- Project-specific adjustments are possible using adaptable control panel for fume cupboard and room
- Project-specific adjustments can be achieved with configurable special functions, monitoring, and alarm signalling
- Permanent function monitoring of the system and the connected sensors
- Very simple commissioning, configuration changes and diagnosis
- Centralised configuring and permanent signalling of room settings (room management function)
- EasyConnect configuration software enables interactive navigation (also wireless)
- Factory tested and configured with project-specific parameters

Parts and characteristics

- Ready-to-commission controller, as an attachment for air terminal units
- Static differential pressure transducer for rapid actual value measurement
- Fast-running high-precision actuator, running time for 90° is 3 s
- Microprocessor system with programme and system data stored in nonvolatile memory
- Double-stack terminal blocks for supply voltage connection
- Connections for two control panels
- Connection of communication line to plug socket or screw terminals
- Digital outputs with screw terminals
- Digital inputs with screw terminals or plug socket
- Analog inputs with screw terminals or plug socket
- Analog outputs with screw terminals or plug socket (actuator)
- Integral terminal resistor for the communication line
- Alarm indicator lights on both sides of the casing
- Status indicator lights (heartbeat, communication and terminal resistor)
- Equipment function FH-VS: Face velocity transducer VS-TRD for measuring the face velocity for fume cupboards
- Equipment function FH-DS, FH-DV: Sash distance sensor DS-TRD-01 for capturing the sash position of a fume cupboard

Construction features

- Main PCB and expansion modules in one casing
- Controller casing is clip-fixed to the VAV terminal unit

- Controller casing can be opened without tools, except for TCU3 with EM-TRF or EM-TRF-USV
- Pin header socket for the connection of expansion modules
- Plug sockets for the most important connections on the outside of the casing
- Static differential pressure transducer with room air induction to protect the sensor

Materials and surface

- Casing made of ABS plastic, blue (RAL 5002)

Installation and commissioning

- Any installation orientation (some installation orientations may require adjusting the position of the differential pressure transducer in the controller casing)
- Carry out zero point correction of the static differential pressure transducer, except for EASYLAB TCU3 with EM-AUTOZERO expansion module
- Connect communication line and activate terminal resistors at both ends
- Component addressing and network management tool are not required
- If necessary, make adjustments using the EasyConnect configuration software
- Set parameters for the room control

Maintenance

- Zero point correction of the static differential pressure transducer should be carried out once per year (recommendation), except for EASYLAB TCU3 with EM-AUTOZERO expansion module

Technical data

Supply voltage	24 V AC ± 15 %; 230 V AC as option; 50/60 Hz
Power rating	35 VA fume cupboard controller with control panel; 29 VA room controller; 33 VA room controller with room control panel; 40 VA max. with all expansion modules
Micro fuse	2 A, slow blow, 250 V
Actuator	Fast-running high-precision actuator, running time for 90° is 3 s
Operating temperature	10 – 50 °C
IEC protection class	III (protective extra-low voltage)
Protection level	IP 20
EC conformity	EMC according to 2004/108/EG
Weight	1.4 kg

Recovery time	500 ms
2 interfaces for communication line	Network cable SF-UTP, 300 m max.; up to 24 devices
2 interfaces for control panels	Network cable SF-UTP, 40 m max.
6 digital inputs	for volt-free switch contacts; can be configured as make or break contacts
6 digital outputs	Relay with make/break contact, 250 V, 12 A; switch-on current 25 A
5 analog inputs	0 – 10 V, input resistance > 100 kΩ, characteristic can be configured
4 analog outputs	0 – 10 V, 10 mA max., characteristic can be configured

Function

Connections and status displays

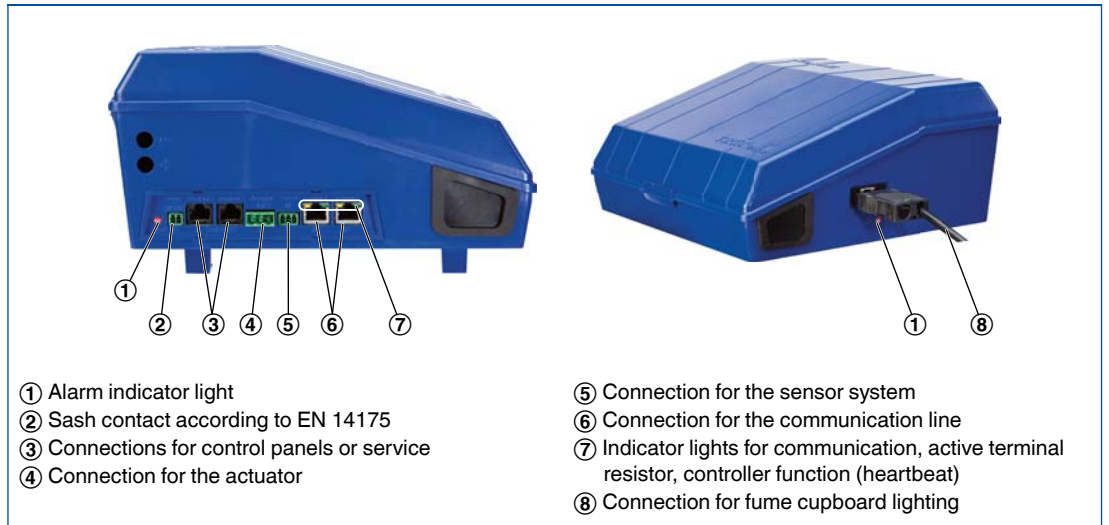

Order code

TVLK with EASYLAB for fume cupboard control

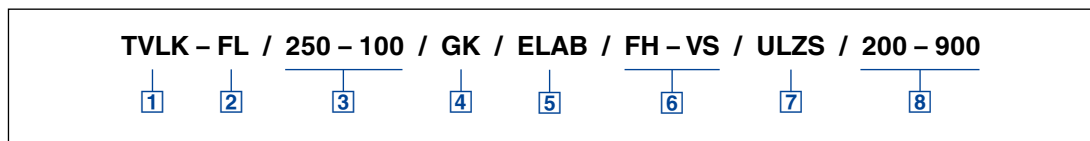

1 Type

TVLK VAV terminal unit made of plastic

2 Flange

No entry: none

FL Flanges on both ends

3 Nominal size

250 – 100 Bluff body 100

250 – 160 Bluff body 160

250 – D10 Venturi nozzle D10

250 – D16 Venturi nozzle D16

4 Accessories

No entry: none

GK Matching flanges for both ends

5 Control component

ELAB EASYLAB controller TCU3 with fast-running actuator

6 Equipment function – fume cupboard control

With face velocity transducer

FH-VS Face velocity control

With sash distance sensor

FH-DS Linear control strategy

FH-DV Safety-optimised control strategy

With switching steps for on-site switch contacts

FH-2P 2 switching steps

FH-3P 3 switching steps

Without signalling

FH-F Volume flow rate constant value

7 Expansion modules

Option 1: Supply voltage

No entry: 24 V AC

T EM-TRF for 230 V AC

U EM-TRF-USV for 230 V AC, provides uninterruptible power supply (UPS)

Option 2: Communications interface

No entry: none

L EM-LON for LonWorks FTT-10A

B EM-BAC-MOD-01 for BACnet MS/TP

M EM-BAC-MOD-01 for Modbus RTU

Option 3: Automatic zero point correction

No entry: none

Z EM-AUTOZERO Solenoid valve for automatic zero point correction

Option 4: Lighting

No entry: none

S EM-LIGHT Wired socket for the connection of lighting and for switching the lighting on/off using the control panel (only with EM-TRF or EM-TRF-USV)

8 Operating values [m³/h or l/s]

Depending on the equipment function

FH-VS: $\dot{V}_{\min} - \dot{V}_{\max}$

FH-DS: $\dot{V}_{\min} - \dot{V}_{\max}$

FH-DV: $\dot{V}_{\min} - \dot{V}_{\max}$

FH-2P: \dot{V}_1 / \dot{V}_2

FH-3P: $\dot{V}_1 / \dot{V}_2 / \dot{V}_3$

FH-F: \dot{V}_1

Useful additions

Control panel for fume cupboard controllers, for displaying the functions of the control system according to EN 14175

BE-SEG-** with 2-character display

BE-LCD-01 with 40-character display

Order example

TVLK/250-100/ELAB/FH-VS/Z/200-900 m³/h

Flange.....none

Nominal size.....250, with bluff body100

Accessoriesnone

Control component EASYLAB controller TCU3 with fast-running actuator

Equipment functionFume cupboard control with face velocity transducer

Expansion modulesEM-AUTOZERO Solenoid valve for automatic zero point correction

Operating values.....200 – 900 m³/h

TVR with EASYLAB for room control

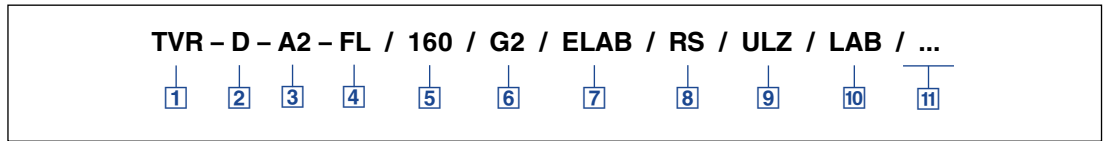

1 Type

TVR VAV terminal unit

2 Acoustic cladding

No entry: none

D With acoustic cladding

3 Material

No entry: galvanised sheet steel

P1 Powder-coated, silver grey (RAL 7001)

A2 Stainless steel

4 Flange

No entry: none

FL Both ends (not for TVR – D – P1)

5 Nominal size [mm]

100

125

160

200

250

315

400

6 Accessories

No entry: none

D2 Lip seals on both ends

G2 Matching flanges for both ends

7 Control component

ELAB EASYLAB controller TCU3 with fast-running actuator

8 Equipment function – room control

RS Room supply air

RE Room extract air

PC Differential pressure control

9 Expansion modules

Option 1: Supply voltage

No entry: 24 V AC

T EM-TRF for 230 V AC

U EM-TRF-USV for 230 V AC, provides uninterruptible power supply (UPS)

Option 2: Communications interface

No entry: none

L EM-LON for LonWorks FTT-10A

B EM-BAC-MOD-01 for BACnet MS/TP

M EM-BAC-MOD-01 for Modbus RTU

Option 3: Automatic zero point correction

No entry: none

Z EM-AUTOZERO Solenoid valve for automatic zero point correction

10 Additional functions

LAB Extract air led system (laboratories)

LAB-RMF Extract air led system with active room management function (laboratories)

CLR Supply air led system (clean room)

CLR-RMF Supply air led system with active room management function (clean room)

11 Operating values [m³/h or l/s, Pa]

Only with additional functions LAB-RMF or CLR-RMF

V1: Total room extract air/supply air – standard mode

V2: Total room extract air/supply air – reduced operation

V3: Total room extract air/supply air – increased operation

V4: Constant room supply air

V5: Constant room extract air

V6: Supply air/extract air difference

$\Delta p_{\text{setpoint}}$: Setpoint pressure (only with differential pressure control)

Useful additions

Room control panel

BE-LCD-01 with 40-character display

Order example

**TVR/160/ELAB/RS/Z/LAB-RMF/1500/1000/
2000/0/0/200 m³/h**

Acoustic cladding.....none
Material..... galvanised sheet steel
Nominal size 160 mm
Flange.....none
Accessoriesnone
Control component EASYLAB controller TCU3
with fast-running actuator
Equipment function –
room control..... Room supply air
Expansion modulesEM-AUTOZERO
Solenoid valve for automatic zero point correction
Additional functionExtract air led system with
active room management function
Operating values.... 1500/1000/2000/0/0/200 m³/h

2

Description

/ FH – ... /

Order code detail

Fume cupboard control

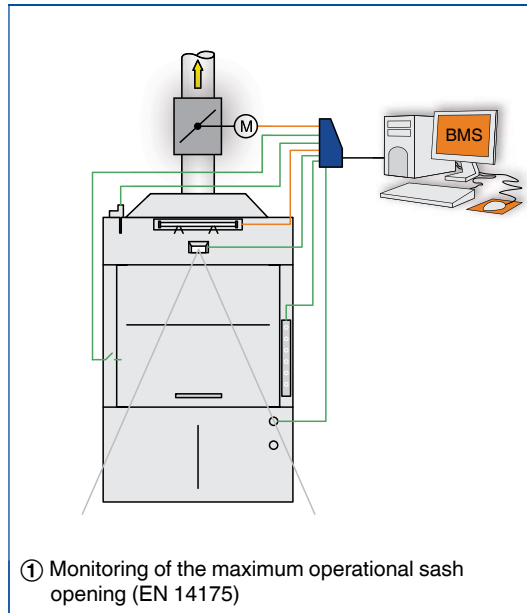

Application

- Volume flow control for fume cupboards
- Combination with plastic VAV terminal units Type TVLK or Type TVRK, or with galvanised sheet steel VAV terminal units Type TVR
- Variable volume flow control to save energy while providing maximum safety
- Control tested to EN 14175, part 6, by an independent testing institute; applies to all fume cupboards that have been tested to EN 14175
- Volume flow rate setpoint values \dot{V}_{min} and \dot{V}_{max} based on fume cupboard tests to EN 14175, carried out by the respective fume cupboard manufacturers

Monitoring and alarm function

- Monitoring of the volume flow rate including configurable optical and acoustic alarms
- Optional monitoring of the face velocity, including configurable optical and acoustic alarms (only for equipment function FH-VS)
- Monitoring of the sash position and signalling when the sash is opened beyond the maximum operational sash opening (EN 14175).
- Optical and acoustic signalling of operating states on the EASYLAB control panel BE-SEG-** or BE-LCD-01
- Two control panels can be used for each fume cupboard controller, e.g. for fume cupboards with sash windows on two sides
- Acoustic signals can be switched off or the signalling period can be limited depending on the monitoring function
- Alarms can be individually configured, e.g. no alarm during reduced operation, flashing alarm, permanent light

Operating modes

- Standard mode with evaluation of the connected sensor system
- Special operating modes: Increased operation, reduced operation, shut-off, and OPEN position

VAV terminal units Type TVLK



Operating mode default setting

- Three levels for setting operating mode defaults (central BMS, room, fume cupboard)
- Configuration options for prioritisation and shut-off
- Operating mode default setting can affect all controllers in a room or a single controller, e.g. 24-hour operation
- Default setting from the central BMS using network variables (LonWorks, BACnet, Modbus) or with switch contacts: room operating mode or fume cupboard operating mode
- Default setting using the room control panel with switch contacts: room operating mode or fume cupboard operating mode
- Default setting using the fume cupboard control panel: fume cupboard operating mode

Installation and commissioning

- Any installation orientation (some installation orientations may require adjusting the position of the differential pressure transducer in the controller casing)
- Install and connect (plug connection) the sensor system and the control panel
- Carry out zero point correction of the static differential pressure transducer, except for EASYLAB TCU3 with EM-AUTOZERO expansion module
- Connect communication line and activate terminal resistors at both ends
- Component addressing and network management tool are not required
- If necessary, make adjustments using the EasyConnect configuration software

Maintenance

- According to the German institution for statutory accident insurance and prevention in the chemical industry (BG Chemie), fume cupboard controllers are subject to maintenance once per year.
- Zero point correction of the static differential

pressure transducer should be carried out once per year (recommendation), except for EASYLAB TCU3 with EM-AUTOZERO expansion module

Special functions

- Application of diversity factors when using EASYLAB room controllers
- Support of fume cupboards with supportive flow technology
- Support of the safe operation of extract air scrubbers
- Connection of a motion sensor to signal 'sash open' or to reduce the face velocity when nobody is working at the fume cupboard
- Smoke extract function for opening or closing the damper blade
- Control of an automatic sash device
- Control of the fume cupboard lighting from the control panel
- Setting the controller action in case the supply voltage fails (only with expansion module EM-TRF-USV)

Interfaces

Inputs

4 analog inputs

- Up to 4 analog inputs with configurable characteristics for the integration of variable flows
- 3 inputs for equipment functions FH-VS, FH-DS, and FH-DV
- 4 inputs for equipment functions FH-2P, FH-3P, and FH-F

6 digital inputs

- The table below shows the available equipment functions, special functions, and the number of inputs required

Outputs

3 analog outputs

- Volume flow rate actual value
- Damper blade position
- Total extract air flow rate, total supply air flow rate, or total supply air flow rate setpoint value

6 digital outputs

- Alarm state
- Control of extract air scrubbers, supportive flow technology, automatic sash device, and fume cupboard lighting

central BMS

- LonWorks FTT-10A (EM-LON)
- BACnet MS/TP (EM-BAC-MOD-01)
- Modbus RTU (EM-BAC-MOD-01)

The following operating values and fault messages of the fume cupboard controller are signalled via the network:

- Volume flow rate actual value and setpoint value
- Damper blade position
- Operating mode
- Face velocity actual value and setpoint value
- Sash opening (FH-DS and FH-DV)
- Switching step (FH-2P and FH-3P)
- Alarm state
- Switching state of the digital inputs and outputs
- Number of controllers within the EASYLAB system
- Total extract air and total supply air volume flow rates
- Evaluated damper blade positions within the system

In addition, extract air and supply air volume flow rates can be permanently integrated into the room balance.

Expansion modules as interfaces to the

Equipment functions and special functions for which digital switching inputs are required

Function	Required inputs
Fume cupboard control with 2 switching steps (FH-2P)	1
Fume cupboard control with 3 switching steps (FH-3P)	up to 2
Monitoring of the maximum operational sash opening (EN 14175 for FH-VS, FH-2P, FH-3P, FH-F)	1
Activation of extract air scrubber	1
Fume cupboards with supportive flow technology	1
Motion detector	1
Smoke extract function	1
Operating mode default setting using switch contacts (only for fume cupboards to which the room operating mode does not apply)	1 per operating mode
Integration of constant volume flow rates using switch contacts	1 per volume flow rate

Control diagrams

/ FH - VS /

Order code detail

Face velocity control

- Variable volume flow control based on the measured face velocity
- Constant face velocity in a working range between \dot{V}_{min} and \dot{V}_{max}
- High thermal loads are detected and dissipated by an increased volume flow rate
- Face velocity can be monitored and displayed
- Non-contact measurement
- For fume cupboards with horizontal and vertical sashes

Control diagram for FH-VS (EASYPAC) and FH (TCU-LON-II)

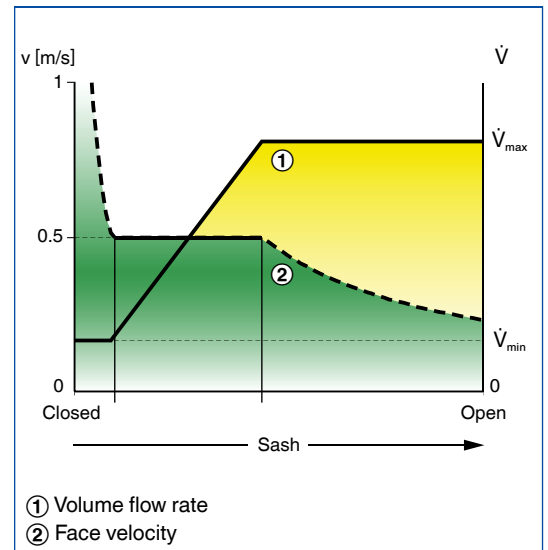

/ FH - DS /

Order code detail

Linear control strategy

- Variable volume flow control based on the measured sash distance
- Volume flow rate is linear to the sash position: OPEN corresponds to \dot{V}_{max} , CLOSED corresponds to \dot{V}_{min}
- Particularly suitable for fume cupboards in rooms with increased airflow (turbulence)
- Sash opening can be monitored according to EN 14175, without additional switch contact

Control diagram for FH-DS

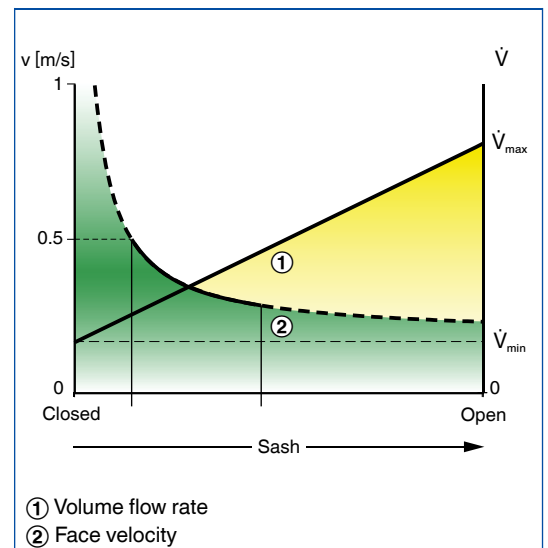

/ FH - DV /

Order code detail

Safety-optimised control strategy

- Safety-optimised volume flow control based on the measured sash distance
- The volume flow rate is linear to the sash position; the aim is to maintain a constant safe face velocity (0.5 m/s) even if the sash is fairly wide open
- Particularly suitable for fume cupboards in rooms with increased airflow (turbulence)
- Sash opening can be monitored according to EN 14175, without additional switch contact

Control diagram for FH-DV

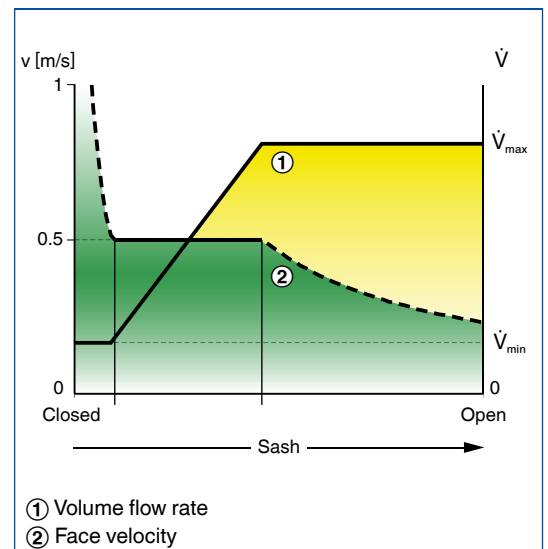

Control diagrams

/ FH – 3P /

Order code detail

Three switching steps

- Volume flow control with three setpoint values
- Switching with two switch contacts (to be provided by others)
- Switch contact for sash distance monitoring according to EN 14175 can be used for one switching step

Control diagram for FH-3P

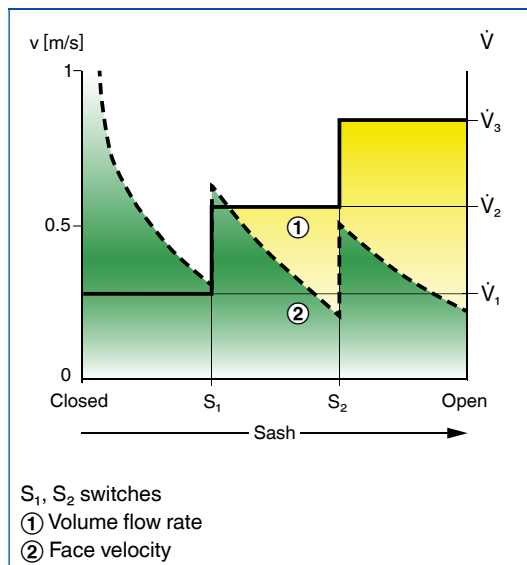

/ FH – 2P /

Order code detail

Two switching steps

- Volume flow control with two setpoint values
- Switching with a switch contact (to be provided by others)

Control diagram for FH-2P

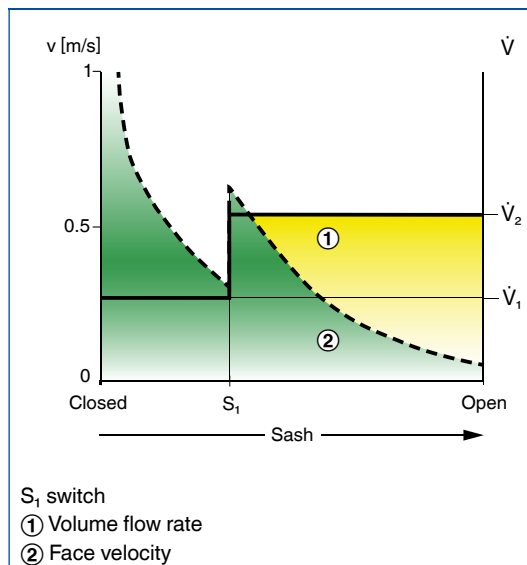

/ FH – F /

Order code detail

Volume flow rate constant value

- Volume flow control with a constant setpoint value

Control diagram for FH-F

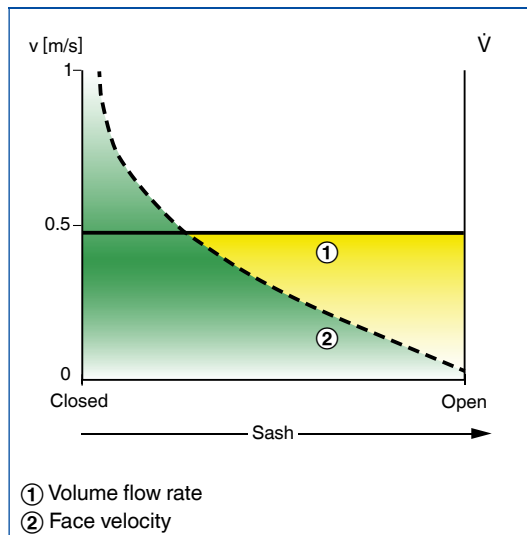

Diversity control

- In many large laboratories the simultaneous operation of all controllers at maximum power is either not desirable or not possible because of the limited capacity of the system
- Diversity control allows for the safe and economical operation of such systems
- With the room management function the total extract air flow rate can be monitored and limited if it exceeds a certain value
- Configuration is done on the controller with room management function
- Available with EASYLAB room controllers in extract air led systems (LAB)

Monitoring of the total extract air flow rate

- The total extract air flow rate is monitored
- An optical alarm is emitted on the room control panel
- Alarms are consolidated for signalling

Limiting the total extract air flow rate

- The total extract air flow rate is monitored
- If it exceeds a certain value, the volume flow rate is reduced for individual fume cupboards, and the total volume flow rate is limited as a consequence
- Reducing the volume flow rate for only selected fume cupboards ensures that as many fume cupboards as possible can be safely used at the same time
- Optical and acoustic alarms are emitted on the fume cupboard for which the volume flow rate has been reduced
- An optical alarm is emitted on the room control panel
- Alarms are consolidated for signalling

Diversity control

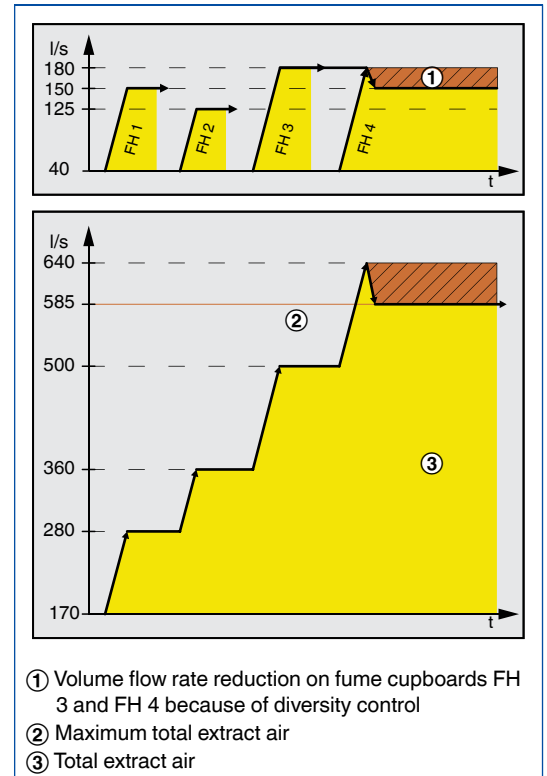

2

Measurement

For detailed information on sensors see Chapter K6 – 2.4

Measurement location of the face velocity transducer (FH-VS, FH)

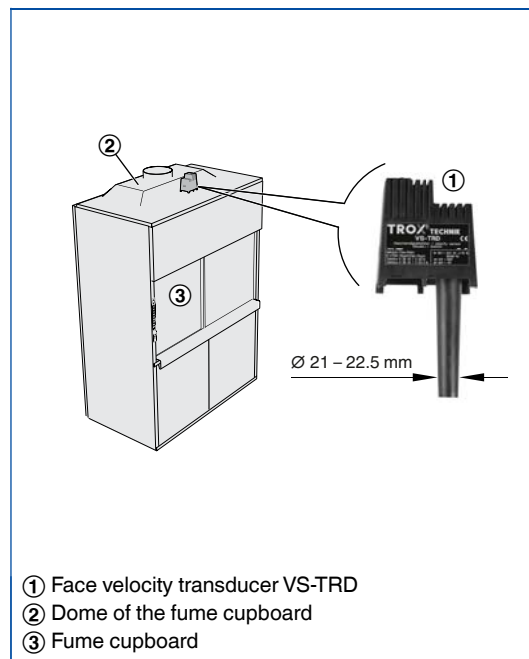

Measurement location of the sash distance sensor (FH-DS, FH-DV)

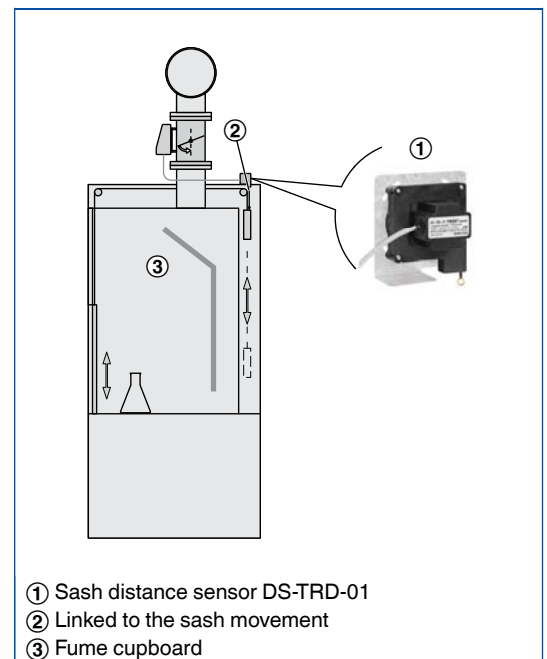

Operation

For detailed information on control panels see Chapter K6 – 2.5

EASYLAB control panel BE-SEG-01, display and control elements

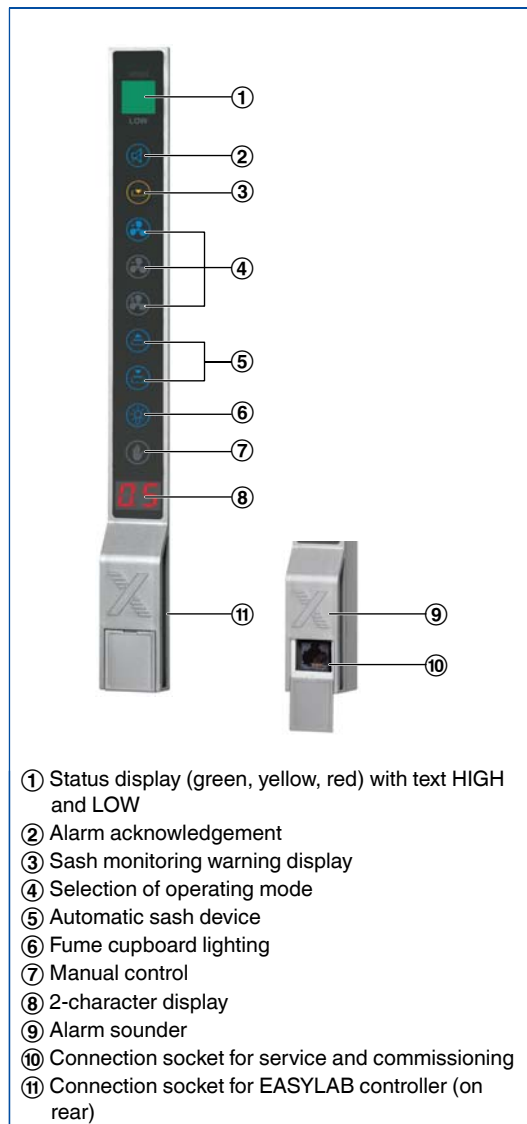

Control panel features

- Push buttons and functions can be configured individually
- Easy to use – available function buttons are visible, unavailable function buttons are not visible
- Buttons for available functions are blue
- Buttons for active functions are white
- Integral service socket for configuration and diagnosis of the controller

EASYLAB control panel BE-LCD-01, display and control elements

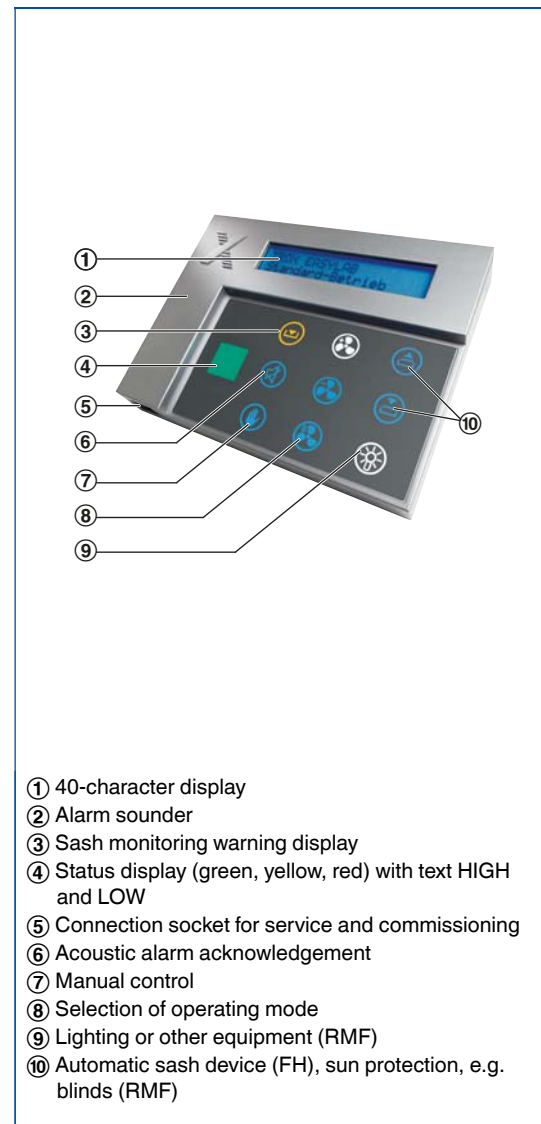

BE-SEG-**

- 2-digit display for system messages or display of the actual face velocity

BE-LCD-01

- Display of actual values, setpoint values, and status messages as text
- Text displays in several languages

Description

/ RS /
/ RE /
/ PC /

Order code detail

Supply air control (example)

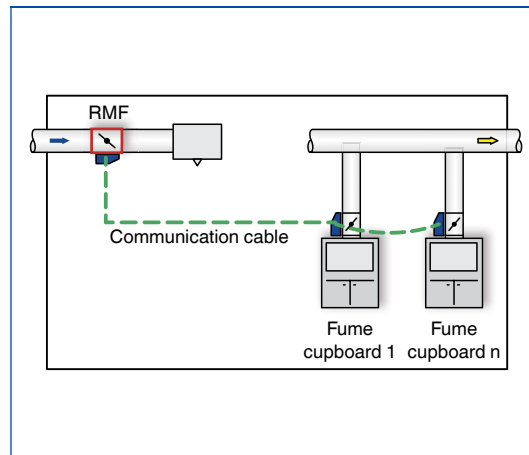

Extract air control (example)

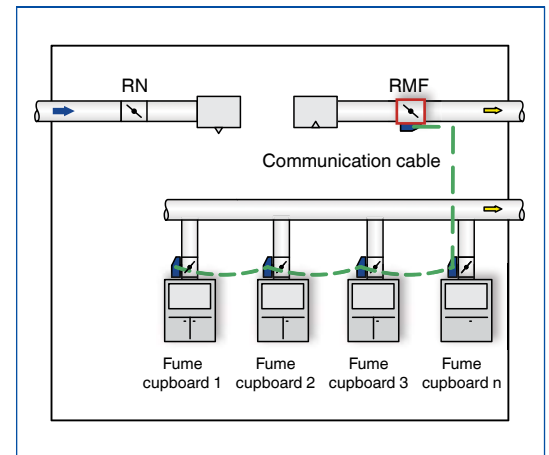

Application

- Variable supply air or extract air flow control for areas where quick-response and stable control is required, e.g. laboratories, clean rooms, hospital wards, and offices with demanding requirements
- Can be combined with VAV terminal units Type TVR, TVRK, TVJ, TVT, TVZ, or TVA
- EASYPAC room control with supply air led and extract air led systems can be configured for two specific applications
- Extract air led system: Rooms with negative pressure, e.g. laboratories
- Supply air led system: Rooms with positive pressure, e.g. clean rooms
- The controllers for a room must be suitable for the selected system, e.g. supply air controllers for RS/.../LAB-RMF, extract air controllers for RE/.../LAB
- Fume cupboard controllers can be used with both systems

Extract air led system (LAB)

- Sizing is based on the minimum total extract air for a room, e.g. to DIN 1946, part 7, 25 m³/h per m²
- Room control aims to maintain the minimum total extract air flow rate
- The extract air controller (master) controls the room extract air flow rate
- The supply air controller (slave) controls the supply air flow rate based on demand and depending on the actual total extract air flow rate
- As an option, the supply air controller can be used to control the differential pressure

Supply air led system (CLR)

- Sizing is based on the total supply air
- Room control aims to maintain the total supply air flow rate
- The supply air controller (master) controls the room supply air flow rate
- The extract air controller (slave) controls the room extract air flow rate based on demand and depending on the actual total extract air flow rate
- As an option, the extract air controller can be used to control the differential pressure

Volume flow rate balancing

- All supply air and extract air flow rates for a room are recorded and added together
- Up to 24 EASYPAC controllers
- Variable volume flow rate signals (voltage signals or network variables LonWorks, BACnet, Modbus)
- Constant volume flow rates can be integrated (using digital inputs)
- Constant volume flow rates (set parameters)

Room pressure or duct pressure control

- Linking volume flow rate balancing with differential pressure control by connecting a differential pressure transducer (room pressure)
- Switching between two pressure setpoint values
- Switching between setpoint values by means of switch contact or network variables LonWorks, BACnet, Modbus
- Adding of a door contact in order to optimise the control function and to emit an alarm when the door is open

Functions

- Stable room balance due to quick-response control
- Volume flow rate monitoring with optical alarm on the controller casing, as well as configurable alarm signalling
- Room operating mode can be overridden by an individual operating mode
- Extract air balance is optimised by a reduction of the room extract air if enough air is already extracted by fume cupboards (extract air led system)
- Automatic supply air or extract air flow distribution where several EASYPAC controllers are installed in a room; distribution according to identical or different volume flow rates (percentages)
- Controlled response in case of a power failure can be defined (EASYPAC TCU3 with expansion module EM-TRF-USV)
- Control input signal for sun protection/blinds (to be provided by others) or for shut-off dampers (to be provided by others) for the volume flow rate dependent optimisation of the diffuser discharge velocity

Operating modes

- Standard mode
- Special operating modes: Increased operation, reduced operation, shut-off, and OPEN position
- Room operating mode is defaulted

Installation and commissioning

- Any installation orientation (some installation orientations may require adjusting the position of the differential pressure transducer in the controller casing)
- Carry out zero point correction of the static differential pressure transducer, except for EASYLAB TCU3 with EM-AUTOZERO expansion module
- Connect communication line and activate terminal resistors at both ends
- Component addressing and network management tool are not required
- If necessary, make adjustments using the EasyConnect configuration software
- Enter room control parameters at one controller (room management function)

Maintenance

- Zero point correction of the static differential pressure transducer should be carried out once per year (recommendation), except for EASYLAB TCU3 with EM-AUTOZERO expansion module

Special functions

Room management function

- Central room interface
- Centralised configuring of room parameters
- Connection of room control panels

Interfaces

If the room management function has been activated, the inputs and outputs described here might be used differently

Inputs

4 analog inputs

- Analog inputs with configurable characteristics for the integration of variable air volume flows

6 digital inputs

- Digital inputs for the integration of constant volume flow rates using switch contacts

Outputs

3 analog outputs

- Volume flow rate actual value
- Controller damper blade position
- Total extract air flow rate, total supply air flow rate, or total supply air flow rate setpoint value (extract air led system)

3 digital outputs

Available functions:

- Alarm state
- Control input signal for shut-off dampers for the volume flow rate dependent optimisation of the diffuser discharge velocity (only equipment function RS)

Expansion modules as interfaces to the central BMS

- LonWorks FTT-10A (EM-LON)
- BACnet MS/TP (EM-BAC-MOD-01)
- Modbus RTU (EM-BAC-MOD-01)

The following operating values and fault messages of the room controller are transferred via the network:

- Volume flow rate actual value and setpoint value
- Damper blade position
- Operating mode
- Alarm state
- Switching state of the digital inputs and outputs
- Number of controllers within the EASYLAB system
- Total extract air and/or total supply air volume flow rates
- Evaluated damper blade position

In addition, extract air or supply air volume flows can be permanently integrated into the room balance.

Control diagrams

/ RS / ... / LAB

Order code detail

Supply air control in an extract air led system

- Control of the demand-based supply air flow rate which results from the actual total extract air flow for the room
- This strategy takes a user-defined difference into account in order to maintain the negative pressure in compliance with DIN 1946, part 7
- Supply air controller = slave

Control diagram for supply air control RS/.../LAB

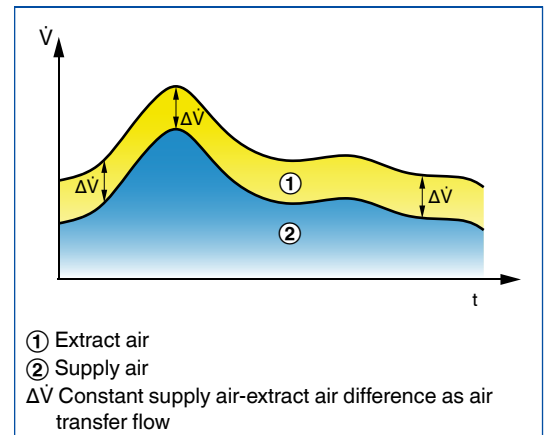

2

/ RE / ... / LAB

Order code detail

Extract air control in an extract air led system

- Control of the room extract air and limitation of the total extract air flow rate of the room
- The volume flow rates for all fume cupboards, extract air controllers, the constant extract air, and the additionally integrated extract air are taken into consideration
- If the total extract air flow rate is not sufficient, the room extract air is controlled accordingly
- Extract air controller = master

Energy saving functions

- If configured accordingly, the extract air controllers will close if sufficient air is extracted by the (open) fume cupboards
- If configured accordingly, the damper blades of the extract air controllers will close outside of normal operating times in order to save energy

Control diagram for equipment function RE/.../LAB

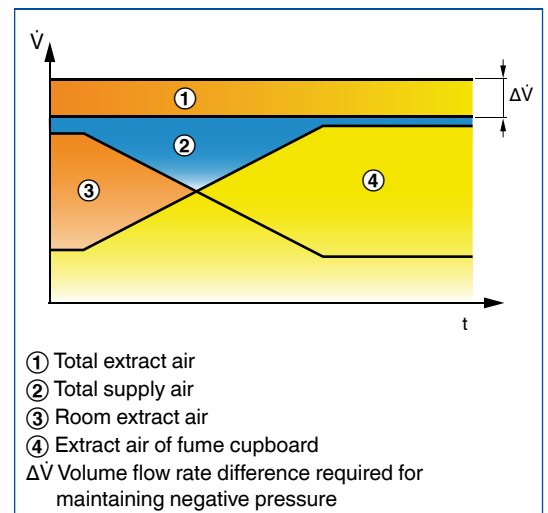

/ PC / ... / LAB

Order code detail

Differential pressure control in an extract air led system

- Linking of the room air balance control with the differential pressure control to quickly achieve a balanced and stable pressure
- The difference between supply air and extract air is variable in the case of differential pressure control
- Differential pressure is controlled by supply air controllers
- Area of application: Maintaining negative pressure in laboratories, for example

Control diagram for equipment function PC/.../LAB

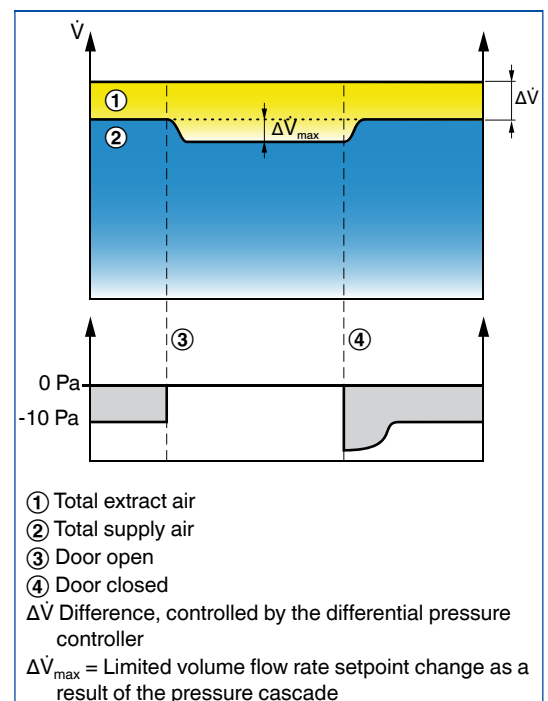

Control diagrams

/ RE / ... / CLR

Order code detail

Extract air control in a supply air led system

- Control of the demand-based extract air flow rate which results from the actual total supply air flow rate for the room
- This strategy takes a user-defined difference into account in order to maintain a positive pressure
- Extract air controller = slave

Control diagram for equipment function RE/.../CLR

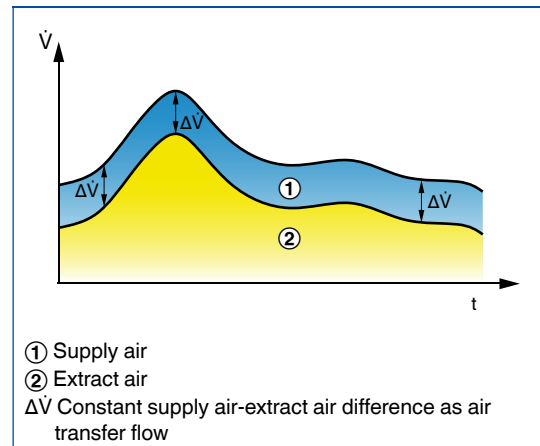

/ RS / ... / CLR

Order code detail

Supply air control in a supply air led system

- Control of the room supply air and limitation of the total supply air flow rate for the room
- The volume flow rates of all supply air controllers, the constant extract air, and the additionally integrated supply air are taken into consideration
- If the total supply air flow rate is not sufficient, the room supply air is controlled accordingly
- Supply air controller = master

Control diagram for equipment function RS/.../CLR

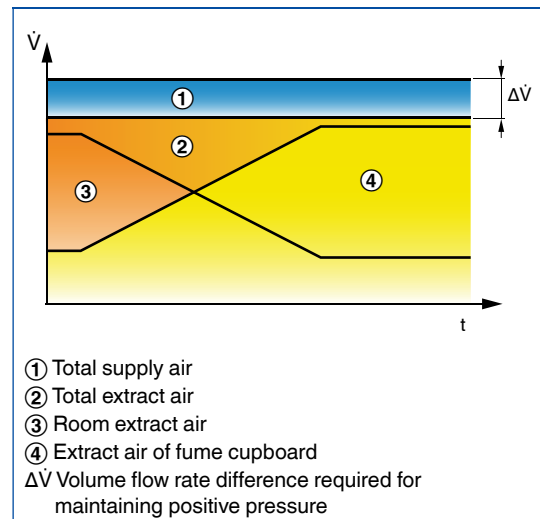

/ PC / ... / CLR

Order code detail

Differential pressure control in a supply air led system

- Linking of the room air balance control with the differential pressure control to quickly achieve a balanced and stable pressure
- The difference between extract and supply air is variable in the case of differential pressure control.
- Differential pressure is controlled by extract air controllers
- Area of application: Maintaining positive pressure in clean rooms, for example

Control diagram for equipment function PC/.../CLR

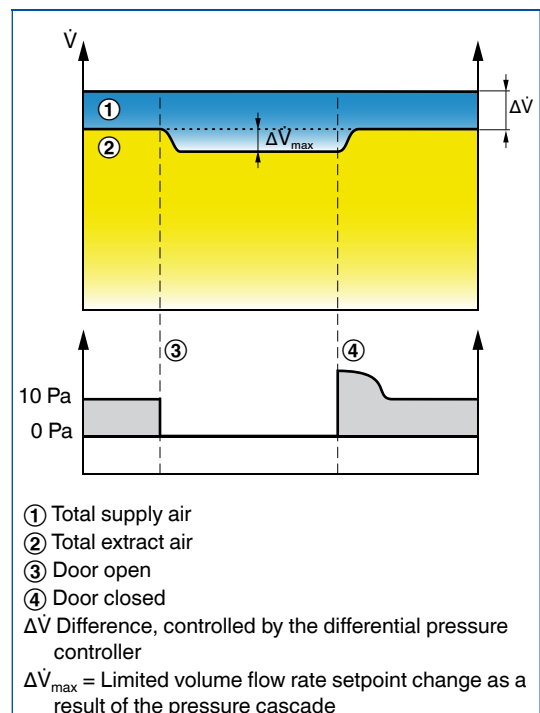

Description

/ LAB – RMF
/ CLR – RMF

Order code detail

Room management function

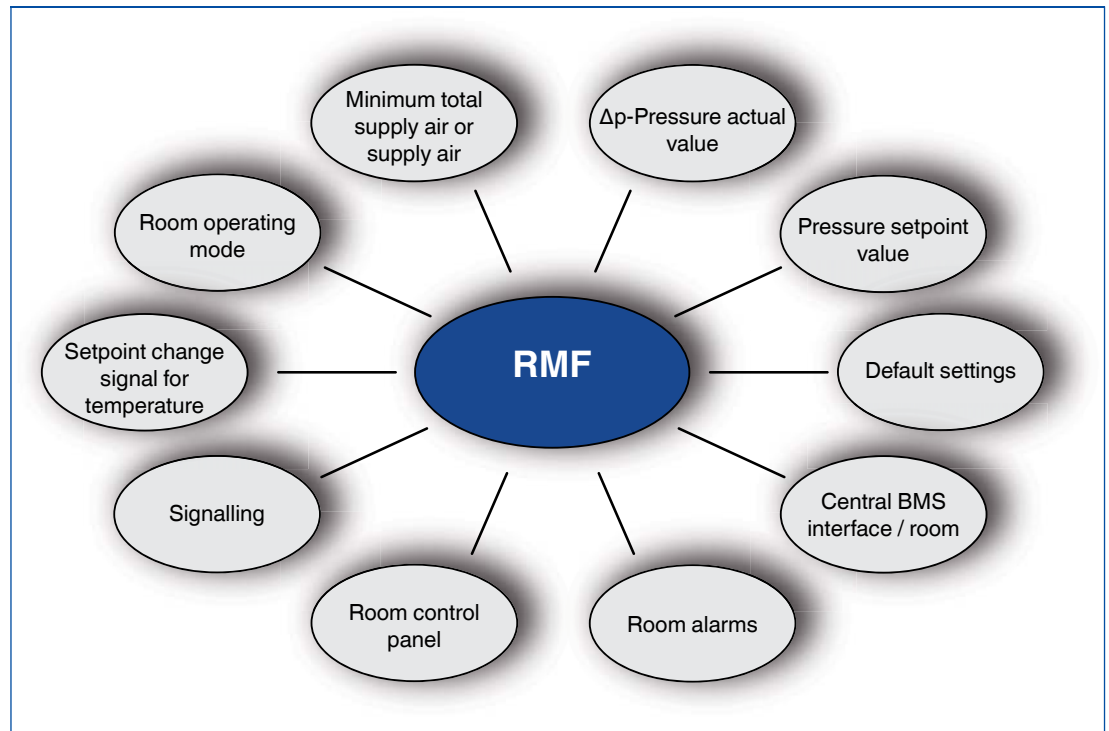

Application

- The room management function is a software option that provides functions for the entire room
- Within an EASYPAC system with a maximum of 24 controllers, the room management function is activated on one controller – supply air controller TCU3, extract air controller TCU3, or TAM adapter module
- Factory set parameters for the room management function
- On-site activation using the EasyConnect configuration software

Central interface point for room functions

- Room operating mode default setting for all controllers in the room; priority can be selected
- Room operating mode default setting using switch contacts LonWorks, BACnet, Modbus, or room control panel
- Volume flow rate setpoint change based on temperature control
- Volume flow rate setpoint change based on external differential pressure control
- Connection of a room pressure transducer, door contact, and setpoint value switching contact for internal differential pressure control
- Control input signal for sun protection/blinds (to be provided by others) and lighting

Centralised configuring of room parameters and functions

- Default setting for the minimum total extract air or the minimum total supply air for the room
- Default setting for the supply air-extract air difference

- Default setting for differential pressure control parameters
- Incorporation of constant, non-switched volume flow rates
- Extract air balance optimisation

Monitoring of room functions

- Exceeding of the specified total extract air (monitoring of diversity) or limitation of the specified total extract air (diversity control)

Configurable consolidated alarms

- Consolidated alarm means that all alarms for all controllers of an EASYPAC system are consolidated

Use of room control panels

- Connection of 2 BE-LCD-01 room control panels
- Status display for the volume flow rate or differential pressure control of a room, e.g. pressure setpoint value and pressure actual value
- Display of actual room parameters, e.g. the actual and setpoint values for the total extract air flow rate
- Service interface for accessing room parameters
- Control of sun protection/blinds (to be provided by others) and lighting

Interfaces

Inputs

4 analog inputs

- Volume flow rate setpoint change based on temperature control
- Volume flow rate setpoint change based on external differential pressure control
- Room pressure actual value for internal differential pressure control
- Connection of variable volume flow rates at inputs that are not used otherwise

6 digital inputs

Available functions:

- Room operating mode default setting: Standard mode, reduced operation, increased operation, shut-off, and OPEN position
- Prioritisation of the room operating mode: by the central BMS or locally
- Switching between two pressure setpoint values in case of internal differential pressure control
- Incorporation of a door contact for internal differential pressure control
- Integration of temporarily constant volume flow rates at inputs that are not used otherwise

Outputs

3 analog outputs

- Volume flow rate actual value for the controller
- Controller damper blade position
- Total extract air flow rate, total supply air flow rate, or total supply air flow rate setpoint value

6 digital outputs

- Alarm for the local controller
- Consolidated alarm for the room
- Differential pressure alarm (only for internal differential pressure control)
- Control input signal for sun protection/blinds (to be provided by others) or for shut-off dampers (to be provided by others) for the volume flow rate dependent optimisation of the diffuser discharge velocity
- Connection of lighting (to be provided by others)

Expansion modules as interfaces to the central BMS

- LonWorks FTT-10A (EM-LON)
- BACnet MS/TP (EM-BAC-MOD-01)
- Modbus RTU (EM-BAC-MOD-01)

The following operating values and fault messages for the room are transferred via the network:

- Operating mode default setting
- Prioritisation of operating mode default settings (central BMS, locally)
- Integration of a volume flow rate setpoint change with regard to temperature or differential pressure control
- Switching between two pressure setpoint values
- Integration of extract air and/or supply air flow rate values for room balancing
- Control input signal for sun protection/blinds (to be provided by others)

Feedback signals from the EASYLAB system (room):

- Room operating mode
- Total extract air flow rate actual value
- Total supply air flow rate actual value
- Evaluated damper blade positions
- Consolidated alarm
- Setpoint and actual values of the internal room pressure control
- Room pressure alarm

Operation

For detailed information on control panels see Chapter K6 – 2.5

EASYLAB control panel BE-LCD-01, display and control elements

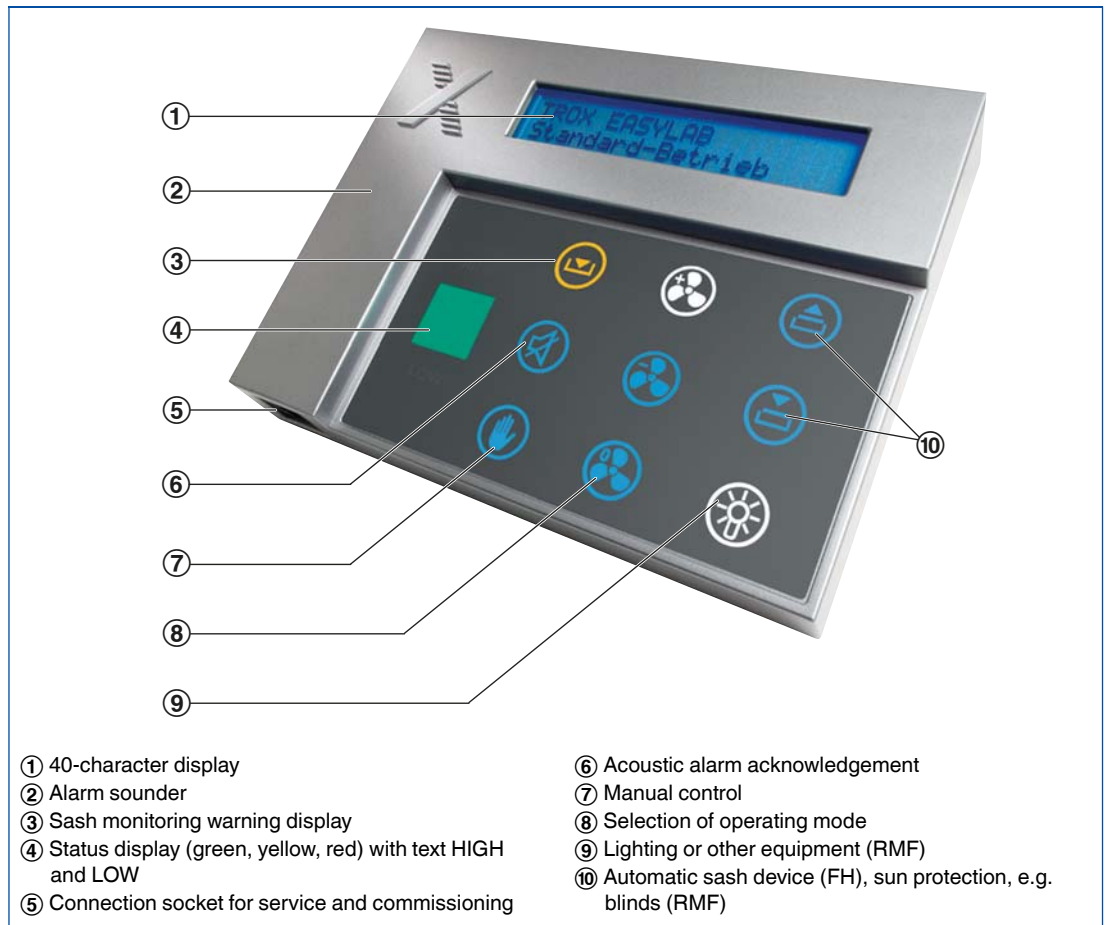

Control panel features

- Push buttons and functions can be configured individually
- Easy to use – available function buttons are visible, unavailable function buttons are not visible
- Buttons for available functions are blue
- Buttons for active functions are white
- Integral service socket for configuration and diagnosis of the controller

Fume cupboard control

Standard text

This specification text describes just one variant of the product that applies to many applications. Texts for other variants can be generated with our Easy Product Finder design programme.

Circular VAV terminal units made of polypropylene (PPs), for variable air volume systems and fume cupboards. Suitable for the control of extract air containing aggressive media since all components coming into contact with the airflow are made of plastic (no interior metal parts).

Ready-to-operate unit consists of the mechanical parts and the electronic control components. Each unit contains a damper blade and an averaging effective pressure sensor with bluff body or a Venturi nozzle for volume flow rate measurement. Factory-assembled control components complete with wiring and tubing.

Effective pressure sensor with 3 mm measuring holes, thus resistant to dust and pollution.

Spigot connection, suitable for ducts according to DIN 8077.

Position of the damper blade indicated externally at shaft extension.

Closed blade air leakage to EN 1751, class 4.

Casing air leakage to EN 1751, class C.

Technical data

- Nominal sizes: 250 mm
- Volume flow rate range: 30 to 360 l/s or 108 to 1296 m³/h
- Volume flow rate control range: approx. 15 to 100 % of the nominal volume flow rate
- Differential pressure range: 5 – 1000 Pa

Control component

Electronic controller for the demand-based control of variable volume flow rates in fume cupboards including the integrated monitoring of the aerodynamic function according to EN 14175 with optical and acoustic signalling.

Factory mounted onto the VAV terminal unit, complete with wiring and tubing, aerodynamically tested and factory set to the customer's parameters

Equipment function:

FH-VS: Volume flow control on the basis of the measured face velocity and incorporating thermal loads. Monitoring of volume flow rate and face velocity.

Control electronics using a microprocessor, with configuration settings stored in EEPROM memory and thus safe in case of a power failure. 5 analog inputs, 6 volt-free digital inputs, 3 analog outputs, and 6 digital outputs as relay changeover contacts. Static differential pressure transducer with room air induction to protect the measurement point. Maintaining of the volume flow rates through a permanent setpoint/actual value comparison in a closed loop with a limitation to minimum and maximum volume flow rates. Connections for all important communication and

peripheral devices are located on the outside of the casing and thus easily accessible. Indicator lights on the outside of the casing for alarms (on both sides), controller function (heartbeat), and communication.

Communication system with plug-in communication lines, automatic connection setup without manual network configuration, easy to expand with additional controllers (usually without integration issues).

Integration of variable or constant volume flow rates in the room balance using voltage signals, switch contacts or constant values. Signalling of volume flow rate actual values, damper blade positions, faults, and status messages to central BMS with analog or switch outputs.

Connection of one or two (for fume cupboards with sash windows on two sides) adaptable EASYPAC control panels BE-SEG-** or BE-LCD-01 with optical and acoustic signalling. Alarm sound can be deactivated or the duration can be limited.

Alarms and alarm signalling are configurable, e.g. suppressing alarms for certain operating modes or consolidating alarms from different levels.

Operating mode default setting by the central BMS, room control panel, or fume cupboard control panel, with flexible prioritisation and shut-off options. Supported special operating modes: increased operation, reduced operation, shut-off, and OPEN position

Additional special functions

- Support of fume cupboards with supportive flow technology
- Safe control of an extract air scrubber
- Connection of motion detectors
- Smoke extract function
- Control of the fume cupboard lighting
- Control of an automatic sash device
- Application of diversity factors in connection with EASYPAC room controllers

5 analog inputs for connecting the sensor system and for integrating up to 4 variable volume flows. 6 volt-free digital inputs for the integration of constant volume flow rates and/or for the control of special functions.

3 analog outputs for signalling volume flow rate actual values and the controller damper blade position as well as the total volume flow rate for the room (supply air, extract air, or supply air setpoint value).

1 digital output for volume flow rate alarm with configurable alarm conditions.

5 digital outputs for various special functions.

Fast-running actuator (run time 90° < 3 s)

Supply voltage 24 V AC

Order options

1 Type

TVLK VAV terminal unit made of plastic

2 Flange

No entry: none

FL Flanges on both ends

3 Nominal size

250 – 100 Bluff body 100

250 – 160 Bluff body 160

250 – D10 Venturi nozzle D10

250 – D16 Venturi nozzle D16

4 Accessories

No entry: none

GK Matching flanges for both ends

5 Control component

ELAB EASYPAC controller TCU3 with fast-running actuator

6 Equipment function – fume cupboard control

With face velocity transducer

FH-VS Face velocity control

With sash distance sensor

FH-DS Linear control strategy

FH-DV Safety-optimised control strategy

With switching steps for on-site switch contacts

FH-2P 2 switching steps

FH-3P 3 switching steps

Without signalling

FH-F Volume flow rate constant value

7 Expansion modules

Option 1: Supply voltage

No entry: 24 V AC

T EM-TRF for 230 V AC

U EM-TRF-USV for 230 V AC, provides uninterruptible power supply (UPS)

Option 2: Communications interface

No entry: none

L EM-LON for LonWorks FTT-10A

B EM-BAC-MOD-01 for BACnet MS/TP

M EM-BAC-MOD-01 for Modbus RTU

Option 3: Automatic zero point correction

No entry: none

Z EM-AUTOZERO Solenoid valve for automatic zero point correction

Option 4: Lighting

No entry: none

S EM-LIGHT Wired socket for the connection of lighting and for switching the lighting on/off using the control panel (only with EM-TRF or EM-TRF-USV)

8 Operating values [m³/h or l/s]

Depending on the equipment function

FH-VS: $\dot{V}_{\min} - \dot{V}_{\max}$

FH-DS: $\dot{V}_{\min} - \dot{V}_{\max}$

FH-DV: $\dot{V}_{\min} - \dot{V}_{\max}$

FH-2P: \dot{V}_1 / \dot{V}_2

FH-3P: $\dot{V}_1 / \dot{V}_2 / \dot{V}_3$

FH-F: \dot{V}_1

Useful additions

Control panel for fume cupboard controllers, for displaying the functions of the control system according to EN 14175

BE-SEG-** with 2-character display

BE-LCD-01 with 40-character display

Room control

Standard text

This specification text describes just one variant of the product that applies to many applications. Texts for other variants can be generated with our Easy Product Finder design programme.

Circular VAV terminal units for variable and constant volume flow systems, suitable for supply or extract air, available in 7 nominal sizes. High control accuracy (even with upstream bend $R = 1D$). Ready-to-operate unit consists of the mechanical parts and the electronic control components. Each unit contains an averaging effective pressure sensor for volume flow rate measurement, and a control damper blade. Factory-assembled control components complete with wiring and tubing. Effective pressure sensor with 3 mm measuring holes, thus resistant to dust and pollution. Spigot connection with groove for lip seal, suitable for connecting ducts according to EN 1506 or EN 13180. Position of the damper blade indicated externally at shaft extension. Closed blade air leakage to EN 1751, class 4 (nominal size 100, class 2; nominal sizes 125 and 160, class 3). Casing air leakage to EN 1751, class C.

Technical data

- Nominal sizes: 100 to 400 mm
- Volume flow rate range: 10 to 1680 l/s or 36 to 6048 m³/h
- Volume flow rate control range (unit with dynamic effective pressure measurement): approx. 10 to 100 % of the nominal volume flow rate
- Differential pressure range: 20 – 1500 Pa

Control component

Electronic controller for demand-based, variable volume flow control of supply or extract air in laboratories and for various tasks in hospitals and clean rooms.

Factory mounted onto the VAV terminal unit, complete with wiring and tubing, aerodynamically tested and factory set to the customer's parameters.

Equipment function:

RS/LAB: Control of the demand-based supply air flow rate which results from the actual total extract air flow for the room; this strategy takes a user-defined difference into account in order to maintain the negative pressure in compliance with DIN 1946, part 7.

Control electronics using a microprocessor, with configuration settings stored in EEPROM memory and thus safe in case of a power failure. 5 analog inputs, 6 volt-free digital inputs, 3 analog outputs, and 6 digital outputs as relay changeover contacts. Static differential pressure transducer with room air induction to protect the measurement point. Maintaining of the volume flow rates through a permanent setpoint/actual value comparison in a closed loop with a limitation to minimum and maximum volume flow rates.

Connections for all important communication and peripheral devices are located on the outside of the casing and thus easily accessible. Indicator lights on the outside of the casing for alarms (on both sides), controller function (heartbeat), and communication.

Communication system with plug-in

communication lines, automatic connection setup without manual network configuration, easy to expand with additional controllers (usually without integration issues).

Integration of variable or constant volume flow rates in the room balance using voltage signals, switch contacts or constant values. Signalling of volume flow rate actual values, damper blade positions, faults, and status messages to central BMS with analog or switch outputs.

Alarms and alarm signalling are configurable, e.g. suppressing alarms for certain operating modes or consolidating alarms from different levels.

Balancing of up to 24 controllers on the communication line (fume cupboards, extract air, supply air, other connections). Automatic distribution of the extract air or supply air flow rates across several EASYLAB volume flow controllers for one room; alternatively, distribution can be configured individually.

Control input signal for sun protection/blinds (to be provided by others) or for shut-off dampers (to be provided by others) for the volume flow rate dependent optimisation of the diffuser discharge velocity

Inputs and outputs

4 analog inputs for integrating variable volume flows

6 digital inputs for integrating constant volume flow rates

3 analog outputs for the signalling of volume flow rate actual value and controller damper blade position as well as (optional) total extract air flow rate, total supply air flow rate, total supply air flow rate setpoint value

1 digital output for volume flow rate alarm with configurable alarm conditions

2 digital outputs for balancing volume flow rates at diffusers

Fast-running actuator (actuation time $90^\circ < 3$ s)

Supply voltage 24 V AC

Additional functions with active room management function

- Connection of one or two adjustable EASYLAB room control panels BE-LCD-01
- Operating mode default setting for all controllers in the room
- Central interface point for individual or consolidated faults
- Monitoring of the room functions in case total extract air flow rate falls short of minimum value or total extract air flow rate exceeds maximum value (diversity)
- Limitation of the total extract air flow rate (diversity control)
- Operating mode default setting by the central BMS, room control panel, or fume cupboard control panel, with flexible prioritisation and shut-off options; special operating modes: increased operation, reduced operation, shut-off, and OPEN position
- Centralised configuring of room parameters
- Volume flow rate setpoint change based on temperature control or on external differential pressure control

- Connection of the pressure transducer for differential pressure control
 - Configurable consolidated alarms
- Inputs and outputs
4 analog inputs for integrating a volume flow rate setpoint change based on temperature, a volume flow rate setpoint change based on pressure, and/or a differential pressure transducer for internal differential pressure control. Unused inputs can be used for integrating variable volume flow rates.
6 volt-free digital inputs for operating mode default setting, switching between two pressure setpoint values and/or a door contact. The remaining inputs which are not used otherwise can be used for integrating constant volume flow rates.

- 3 analog outputs for the signalling of volume flow rate actual value and controller damper blade position as well as (optional) total extract air flow rate, total supply air flow rate, or total supply air flow rate setpoint value
6 digital outputs for volume flow rate alarm, pressure alarm with internal differential pressure control, consolidated alarm, volume flow rate optimisation at diffusers, or integration of sun protection/blinds and/or lighting or devices. Alarm conditions can be configured.

Order options

1 Type

- TVR** VAV terminal unit

2 Acoustic cladding

- No entry: none
 D With acoustic cladding

3 Material

- No entry: galvanised sheet steel
 P1 Powder-coated, silver grey (RAL 7001)
 A2 Stainless steel

4 Flange

- No entry: none
 FL Both ends (not for TVR – D – P1)

5 Nominal size [mm]

- 100**
 125
 160
 200
 250
 315
 400

6 Accessories

- No entry: none
 D2 Lip seals on both ends
 G2 Matching flanges for both ends

7 Control component

- ELAB** EASYLAB controller TCU3 with fast-running actuator

8 Equipment function – room control

- RS** Room supply air
 RE Room extract air
 PC Differential pressure control

9 Expansion modules

- Option 1: Supply voltage
No entry: 24 V AC
 T EM-TRF for 230 V AC
 U EM-TRF-USV for 230 V AC, provides uninterruptible power supply (UPS)
Option 2: Communications interface
No entry: none
 L EM-LON for LonWorks FTT-10A
 B EM-BAC-MOD-01 for BACnet MS/TP
 M EM-BAC-MOD-01 for Modbus RTU
Option 3: Automatic zero point correction
No entry: none
 Z EM-AUTOZERO Solenoid valve for automatic zero point correction

10 Additional functions

- LAB** Extract air led system (laboratories)
 LAB-RMF Extract air led system with active room management function (laboratories)
 CLR Supply air led system (clean room)
 CLR-RMF Supply air led system with active room management function (clean room)

11 Operating values [m³/h or l/s, Pa]

- Only with additional functions LAB-RMF or CLR-RMF
 $\dot{V}1$: Total room extract air/supply air – standard mode
 $\dot{V}2$: Total room extract air/supply air – reduced operation
 $\dot{V}3$: Total room extract air/supply air – increased operation
 $\dot{V}4$: Constant room supply air
 $\dot{V}5$: Constant room extract air
 $\dot{V}6$: Supply air/extract air difference
 $\Delta p_{\text{setpoint}}$: Setpoint pressure (only with differential pressure control)

Useful additions

- Room control panel
 BE-LCD-01 with 40-character display

2

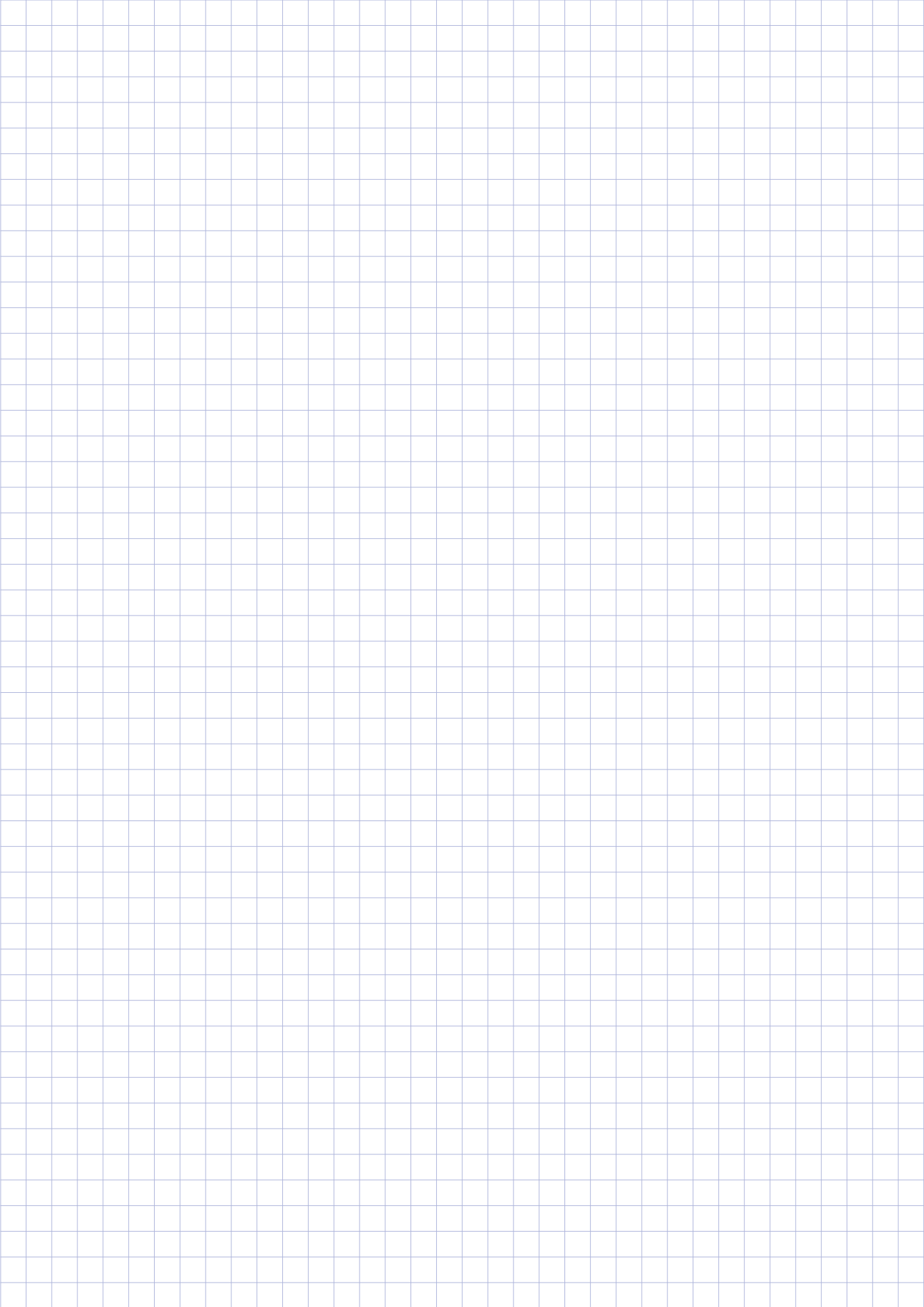

Controller

Type TAM



2

Adapter module for the expansion of the EASYLAB system

Adapter module as an interface between fume cupboard control and room control, and to the central BMS

- Plug and play communication with up to 23 EASYLAB controllers, fume cupboard controllers, or room controllers
- Additional data points for the integration of other variable and constant volume flow rates into the room balance, e.g. controllers or fume hoods
- Can be set up as room interface to the central BMS
- Connection of a room control panel for the signalling and use of room functions

Expansion options

- Connection to the mains (230 V)
- Expansion modules with LonWorks, BACnet or Modbus standard interfaces to the central BMS
- Room control panels for operating mode default setting

Type		Page
TAM	General information	2.1 – 28
	Order code	2.1 – 31
	Equipment functions	2.1 – 32
	Equipment functions – room management function	2.1 – 34
	Specification text	2.1 – 37
	Basic information and nomenclature	2.7 – 1

Expansion of the EASYLAB system using the TAM adapter module

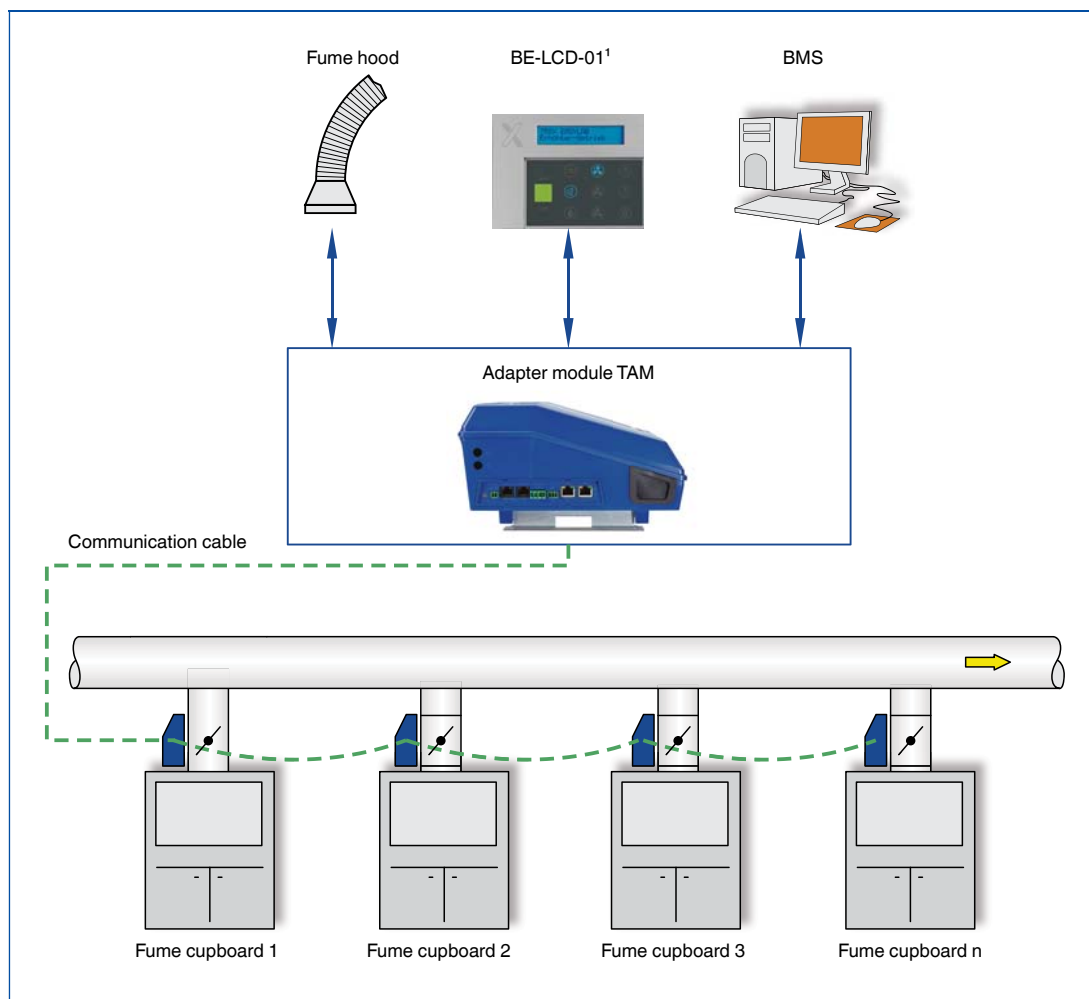

¹ only for a TAM with active room management function

Description



EASYLAB adapter module TAM

Application

- Adapter module Type TAM for the expansion of the EASYLAB system
- Interface between fume cupboard control and room control
- Interface to the central BMS, voltage signals 0 – 10 V or with expansion modules for LonWorks, BACnet, Modbus
- Very simple commissioning: automatic controller identification, no component addressing required (plug and play communication), configuration software with interactive menu navigation and extended diagnostic functions

- Project-specific configuration using expansion modules and room control panels
- Numerous options for the integration of additional volume flows into the room balance
- Room management function (RMF) can be activated
- For use in laboratories, clean rooms in the pharmaceutical and semiconductor industries, operation theatres, intensive care units, and offices with very demanding control requirements

Operating modes

- LAB: extract air led system for laboratories
- CLR: supply air led system for clean rooms
- LAB/CLR-RMF: System with active room management function

Attachments

Expansion modules are factory mounted or can be fitted at a later stage

- T: EM-TRF, power supply unit for connecting the controller to the 230 V AC mains voltage
- U: EM-TRF-USV, power supply unit for connecting the controller to the 230 V AC mains voltage and to ensure uninterrupted power supply
- L: EM-LON, LonWorks FTT-10A interface
- B: EM-BAC-MOD-01, interface configured for BACnet MS/TP
- M: EM-BAC-MOD-01, interface configured for Modbus RTU

Useful additions

- BE-LCD-01: Control panel for fume cupboard control and room control (only for operating mode ...-RMF)
- Differential pressure transducers: Static differential pressure transducers for room pressure control or duct pressure control
- EasyConnect: Configuration software for the commissioning and diagnosis of EASYLAB components

Special features

- Plug and play communication with automatic controller identification, no component addressing required
- Modular system for functional expansion
- Connections and status displays on the outside of the controller casing
- Project-specific adjustments using adaptable room control panels
- Project-specific adjustments can be achieved with configurable special functions, monitoring, and alarm signalling
- Permanent function monitoring of the system
- Very simple commissioning, configuration changes and diagnosis
- Centralised configuring and permanent signalling of room settings (room management function)
- EasyConnect configuration software enables interactive navigation (also wireless)
- Factory tested and configured with project-specific parameters

Parts and characteristics

- Microprocessor system with programme and system data stored in nonvolatile memory
- Double-stack terminal blocks for supply voltage connection
- Connections for two control panels
- Connection of communication line to plug socket or screw terminals
- Digital outputs with screw terminals
- Digital inputs with screw terminals or plug socket
- Analog inputs with screw terminals or plug socket
- Analog outputs with screw terminals
- Integral terminal resistor for the communication line
- Alarm indicator lights on both sides of the casing
- Status indicator lights (heartbeat, communication and terminal resistor)

Construction features

- Main PCB and expansion modules in one casing
- Angle bracket for fixing the casing in a switch cabinet or to a wall or ceiling
- Casing can be opened without tools, except for TAM with EM-TRF or EM-TRF-USV
- Pin header socket for the connection of expansion modules
- Plug sockets for the most important connections on the outside of the casing

Materials and surface

- Casing made of ABS plastic, blue (RAL 5002)

Installation and commissioning

- Use the angle bracket to fix the casing in a switch cabinet or to a wall or ceiling
- Connect communication line and activate terminal resistors at both ends
- Component addressing and network management tool are not required
- If necessary, make adjustments using the EasyConnect configuration software

Technical data

Supply voltage	24 V AC \pm 15 %; 230 V AC as option; 50/60 Hz
Power rating	9 VA max.
Micro fuse	2 A, slow blow, 250 V
Operating temperature	10 – 50 °C
IEC protection class	III (protective extra-low voltage)
Protection level	IP 20
EC conformity	EMC according to 2004/108/EG
Weight	1.7 kg including fixing bracket

Recovery time	500 ms
2 interfaces for communication line	Network cable SF-UTP, 300 m max.; up to 24 devices
2 interfaces for control panels	Network cable SF-UTP, 40 m max.
6 digital outputs	Relay with make/break contact, 250 V, 12 A; switch-on current 25 A
6 digital inputs	for volt-free switch contacts; can be configured as make or break contacts
5 analog inputs	0 – 10 V, input resistance > 100 k Ω , characteristic can be configured
4 analog outputs	0 – 10 V, 10 mA max., characteristic can be configured

Function

Connections and status displays – TAM

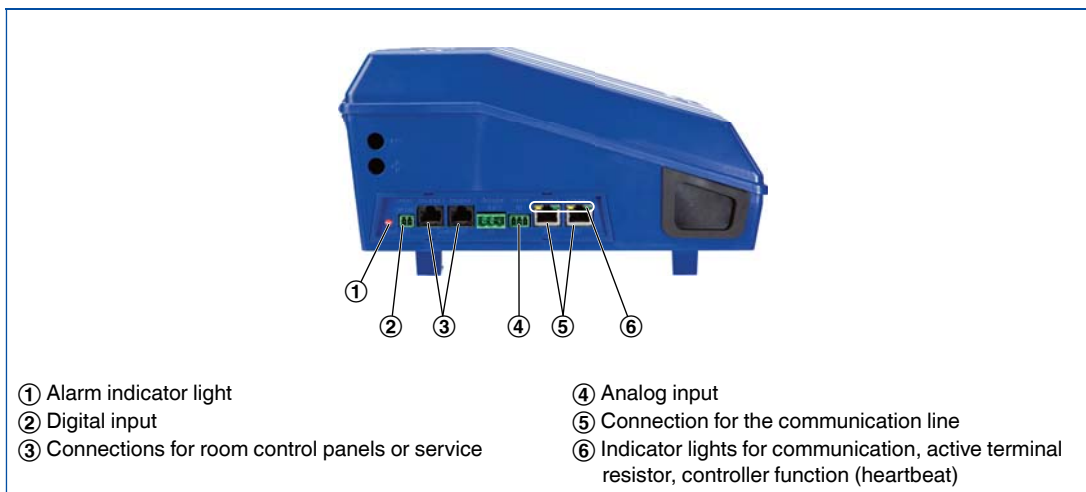

Order code

TAM

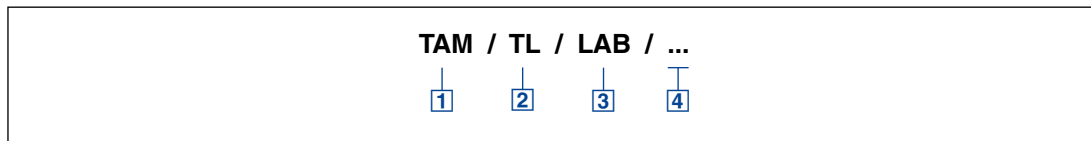

1 Type

TAM Adapter module

2 Expansion modules

Option 1: Supply voltage

No entry: 24 V AC

T EM-TRF for 230 V AC

U EM-TRF-USV for 230 V AC, provides uninterruptible power supply (UPS)

Option 2: Communications interface

No entry: none

L EM-LON for LonWorks-FTT-10A

B EM-BAC-MOD-01 for BACnet MS/TP

M EM-BAC-MOD-01 for Modbus RTU

3 Operating mode

LAB Extract air led system (laboratories)

LAB-RMF Extract air led system with active room management function (laboratories)

CLR Supply air led system (clean room)

CLR-RMF Supply air led system with active room management function

4 Operating values [m³/h or l/s, Pa]

Only with operating mode LAB-RMF or CLR-RMF

$\dot{V}1$ Total room extract air/supply air – standard mode

$\dot{V}2$ Total room extract air/supply air – reduced operation

$\dot{V}3$ Total room extract air/supply air – increased operation

$\dot{V}4$ Constant room supply air

$\dot{V}5$ Constant room extract air

$\dot{V}6$ Supply air/extract air difference

$\Delta p_{\text{setpoint}}$ Setpoint pressure (only with differential pressure control)

Useful additions

Room control panel

BE-LCD-01 with 40-character display

Order example

TAM/T/LAB

Expansion module EM-TRF for supply voltage

LAB..... Extract air led system

Description

Volume flow rate consolidated signal

The adapter module consolidates signals from all connected controllers and provides this consolidated signal as a voltage signal; with expansion modules EM-LON and EM-BAC-MOD-01 the signal is provided as network variable. Supply air and extract air signals are considered.

Variable volume flows

- The system considers up to 23 EASYLAB controllers that are connected to the communication line
- The system considers up to 5 voltage signals that are connected to the analog inputs
- The system considers up to 2 network variables, transferred via a LonWorks, BACnet, or Modbus interface

Constant volume flows

- The system considers up to 6 configurable constant volume flow rates, connected to the digital inputs

Room management function

- The room management function can be activated using the adapter module

Interfaces

Inputs

5 analog inputs

- Analog inputs with configurable characteristics for the integration of variable air volume flows

6 digital inputs

- Digital inputs for the integration of constant volume flow rates using switch contacts

Outputs

1 analog output

- Total extract air flow rate, total supply air flow rate, or total supply air flow rate setpoint value (setpoint value: only for extract air led system)

1 digital output

- Alarm state of the adapter module

Expansion modules as interfaces to the central BMS

- LonWorks FTT-10A (EM-LON)
- BACnet MS/TP (EM-BAC-MOD-01)
- Modbus RTU (EM-BAC-MOD-01)

The following operating values and fault messages of the adapter module are transferred via the network:

- Alarm state
- Switching state of the digital inputs and outputs
- Number of controllers within the EASYLAB system
- Total extract air flow rates and/or total supply air flow rates
- Evaluated damper blade positions within the system

In addition, extract air or supply air volume flows can be permanently integrated into the room balance.

TAM interfaces

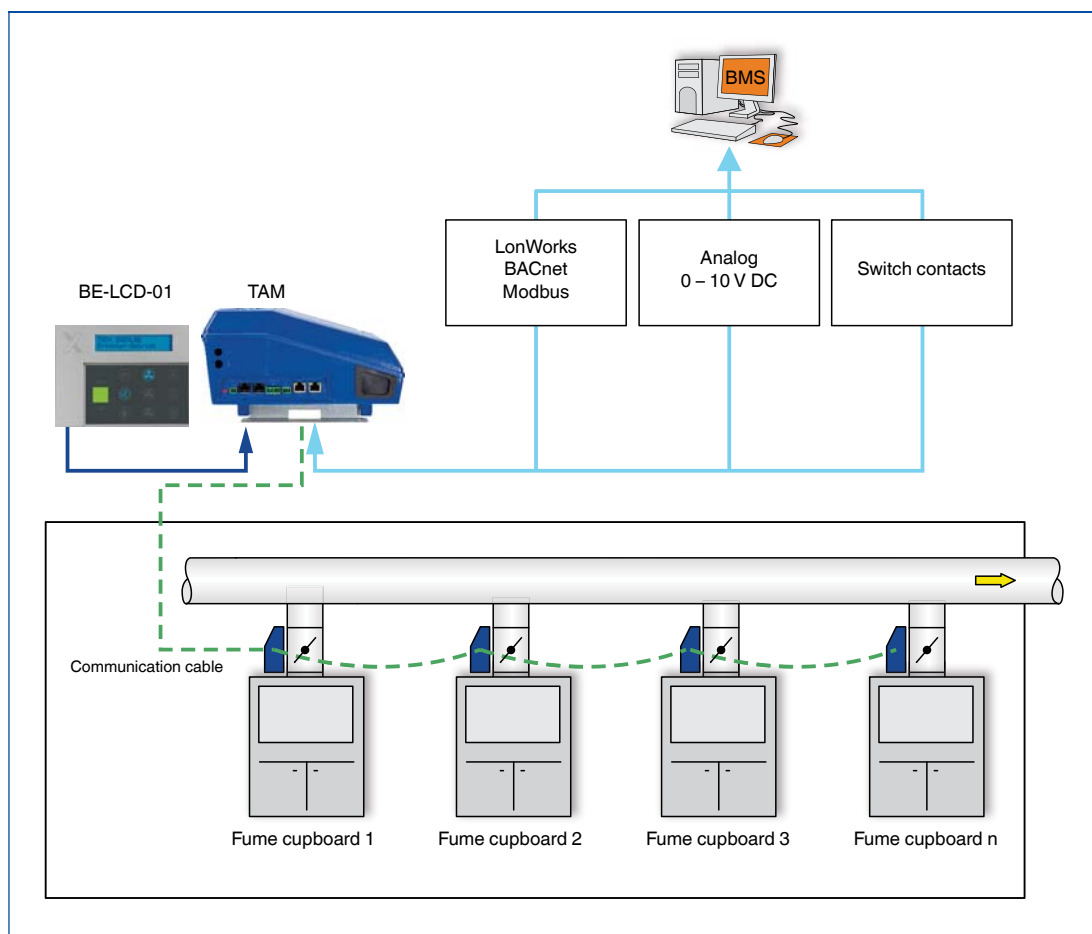

Description

/ LAB – RMF
/ CLR – RMF

Order code detail

Room management function

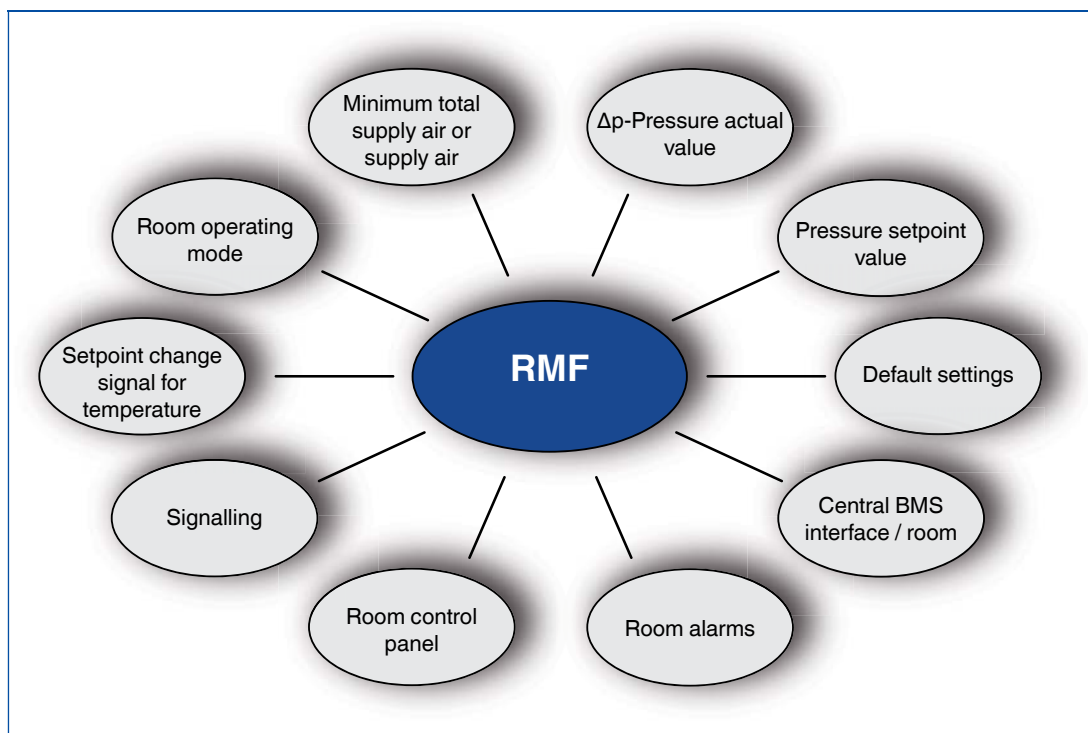

Application

- The room management function is a software option that provides functions for the entire room
- Within an EASYLAB system with a maximum of 24 controllers, the room management function is activated on one controller – supply air controller TCU3, extract air controller TCU3, or TAM adapter module
- Factory set parameters for the room management function
- On-site activation using the EasyConnect configuration software

Central interface point for room functions

- Room operating mode default setting for all controllers in the room; priority can be selected
- Room operating mode default setting using switch contacts LonWorks, BACnet, Modbus, or room control panel
- Volume flow rate setpoint change based on temperature control
- Volume flow rate setpoint change based on external differential pressure control
- Connection of a room pressure transducer, door contact, and setpoint value switching contact for internal differential pressure control
- Control input signal for sun protection/blinds (to be provided by others) and lighting

Centralised configuring of the room parameters and functions

- Default setting for the minimum total extract air or the minimum total supply air for the room
- Default setting for the supply air-extract air difference
- Default setting for differential pressure control parameters
- Incorporation of constant, non-switched volume flow rates
- Extract air balance optimisation

Monitoring of room functions

- Exceeding of the specified total extract air (monitoring of diversity) or limitation of the specified total extract air (diversity control)

Configurable consolidated alarms

- Consolidated alarm means that all alarms for all controllers of an EASYLAB system are consolidated

Use of room control panels

- Connection of 2 BE-LCD-01 room control panels
- Status display for the volume flow rate or differential pressure control of a room, e.g. pressure setpoint value and pressure actual value
- Display of actual room parameters, e.g. the actual and setpoint values for the total extract air flow rate
- Service interface for accessing room parameters
- Control of sun protection/blinds (to be provided by others) and lighting

Interfaces

Inputs

4 analog inputs

- Volume flow rate setpoint change based on temperature control
- Volume flow rate setpoint change based on external differential pressure control
- Room pressure actual value for internal differential pressure control
- Connection of variable volume flow rates at inputs that are not used otherwise

6 digital inputs

Available functions:

- Room operating mode default setting: Standard mode, reduced operation, increased operation, shut-off, and OPEN position
- Prioritisation of the room operating mode: by the central BMS or locally
- Switching between two pressure setpoint values in case of internal differential pressure control
- Incorporation of a door contact for internal differential pressure control
- Integration of temporarily constant volume flow rates at inputs that are not used otherwise

Outputs

1 analog output

- Total extract air flow rate, total supply air flow rate, or total supply air flow rate setpoint value

6 digital outputs

- Alarm for the local adapter module
- Consolidated alarm for the room
- Differential pressure alarm (only for internal differential pressure control)
- Control input signal for sun protection/blinds (to be provided by others) or for shut-off dampers (to be provided by others) for the volume flow rate dependent optimisation of the diffuser discharge velocity
- Connection of lighting (to be provided by others)

Expansion modules as interfaces to the central BMS

- LonWorks FTT-10A (EM-LON)
- BACnet MS/TP (EM-BAC-MOD-01)
- Modbus RTU (EM-BAC-MOD-01)

The following operating values and fault messages for the room are transferred via the network:

- Operating mode default setting
- Prioritisation of operating mode default settings (central BMS, locally)
- Integration of a volume flow rate setpoint change with regard to temperature or differential pressure control
- Switching between two pressure setpoint values
- Integration of extract air and/or supply air flow rate values for room balancing
- Control input signal for sun protection/blinds (to be provided by others)

Feedback signals from the EASYLAB system (room):

- Room operating mode
- Total extract air flow rate actual value
- Total supply air flow rate actual value
- Evaluated damper blade positions
- Consolidated alarm
- Setpoint and actual values of the internal room pressure control
- Room pressure alarm

Operation

For detailed information on control panels see Chapter K6 – 2.5

EASYPAN control panel BE-LCD-01, display and control elements

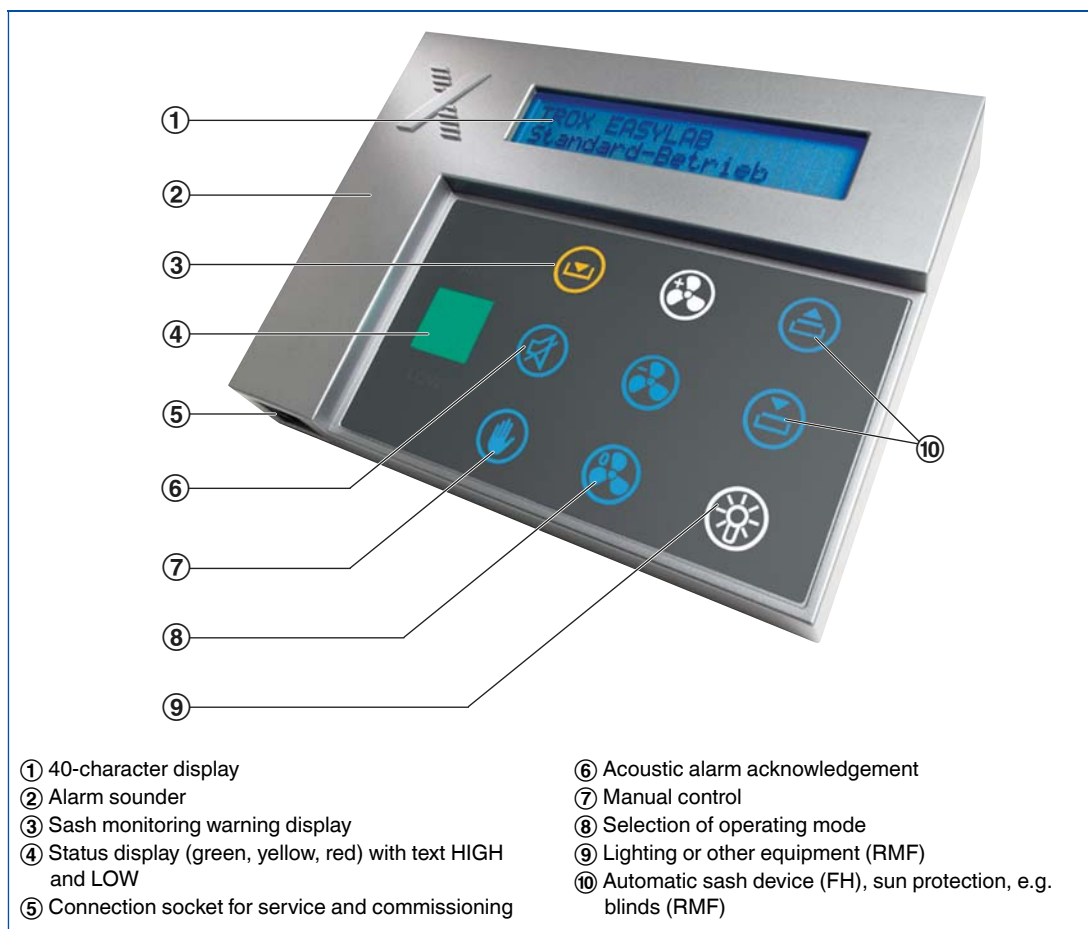

Control panel features

- Push buttons and functions can be configured individually
- Easy to use – available function buttons are visible, unavailable function buttons are not visible
- Buttons for available functions are blue
- Buttons for active functions are white
- Integral service socket for configuration and diagnosis of the controller

Standard text

This specification text describes just one variant of the product that applies to many applications. Texts for other variants can be generated with our Easy Product Finder design programme.

Adapter module for the EASYLAB system as an interface between fume cupboard control and room control

Control electronics using a microprocessor, with configuration settings stored in EEPROM memory and thus safe in case of a power failure.

Connections for all important communication and peripheral devices are located on the outside of the casing and thus easily accessible. Indicator lights on the outside of the casing for alarms (on both sides), controller function (heartbeat), and communication.

Communication system with plug-in communication lines, automatic connection setup without manual network configuration, easy to expand with additional controllers (usually without integration issues).

Integration of variable or constant volume flow rates in the room balance using analog signals, switch contacts or constant values. Signalling of volume flow rate consolidated signals, faults, and status messages to central BMS with analog or switch outputs.

5 analog inputs for the integration of variable volume flows.

6 volt-free digital inputs for the integration of constant flows and/or the control of special functions.

Analog output for signalling the total volume flow rate of the room (supply air or extract air)

Digital output for an alarm; alarm conditions can be configured.

Supply voltage 24 V AC

Special features

- Plug and play communication with automatic controller identification, no component addressing required
- Modular system for functional expansion
- Connections and status displays on the outside of the controller casing

- Project-specific adjustments using adaptable room control panels
- Project-specific adjustments can be achieved with configurable special functions, monitoring, and alarm signalling
- Permanent function monitoring of the system
- Very simple commissioning, configuration changes and diagnosis
- Centralised configuring and permanent signalling of room settings (room management function)
- EasyConnect configuration software enables interactive navigation (also wireless)
- Factory tested and configured with project-specific parameters

Materials and surface

- Casing made of ABS plastic, blue (RAL 5002)

Additional functions with active room management function

- Connection of one or two adaptable EASYLAB control panels BE-LCD-01 with optical and acoustic signalling
- The alarm sound can be suppressed or its duration limited; alarm signalling is configurable, e.g. suppressing alarms for certain operating modes or consolidating alarms from different levels
- Operating mode default setting by the central BMS and/or room control panel with flexible suppression and prioritisation options
- Supported special operating modes: increased operation, reduced operation, shut-off, and open position
- Operating mode default setting for all controllers in the room
- Central interface for individual faults
- Monitoring of room functions
- Centralised configuring of room parameters

Order options

1 Type

TAM Adapter module

2 Expansion modules

- Option 1: Supply voltage
No entry: 24 V AC
- T** EM-TRF for 230 V AC
 - U** EM-TRF-USV for 230 V AC, provides uninterruptible power supply (UPS)
- Option 2: Communications interface
No entry: none
- L** EM-LON for LonWorks-FTT-10A
 - B** EM-BAC-MOD-01 for BACnet MS/TP
 - M** EM-BAC-MOD-01 for Modbus RTU

3 Operating mode

- LAB** Extract air led system (laboratories)
- LAB-RMF** Extract air led system with active room management function (laboratories)
- CLR** Supply air led system (clean room)
- CLR-RMF** Supply air led system with active room management function

4 Operating values [m³/h or l/s, Pa]

- Only with operating mode LAB-RMF or CLR-RMF
- $\dot{V}1$ Total room extract air/supply air – standard mode
 - $\dot{V}2$ Total room extract air/supply air – reduced operation
 - $\dot{V}3$ Total room extract air/supply air – increased operation
 - $\dot{V}4$ Constant room supply air
 - $\dot{V}5$ Constant room extract air
 - $\dot{V}6$ Supply air/extract air difference
 - $\Delta p_{\text{setpoint}}$ Setpoint pressure (only with differential pressure control)

Useful additions

- Room control panel
- BE-LCD-01** with 40-character display

2





TCU-LON-II with fast-running actuator



LonMark Partner



For laboratories



For hospitals



For clean rooms, e.g. in semiconductor manufacturing

Controller Type TCU-LON-II



LON controller for the most demanding control engineering tasks

Electronic controller with LON communication for demanding control tasks in buildings with LonWorks infrastructure

- Maximum control comfort for laboratories, clean rooms, hospital wards, and offices
- Perfect system for complete room solutions from a single source
- Demand-based and quick-response control for fume cupboards, and of supply air, extract air and pressure
- LonWorks FTT-10A interface: Two-core cable with reverse voltage protection, hence minimum wiring effort
- Standard network variables (SNVT) ensure simple integration into central BMS
- Complete configuration of controllers due to LonWorks and remote access
- Can be combined with volume flow controllers: TVLK, TVRK, TVR, TVA, TVZ, TVT, TVJ

When used for fume cupboard control

- Control and monitoring with display according to EN 14175
- Many configurable special functions

Type		Page
TCU-LON-II	General information	2.1 – 40
	Order code	2.1 – 44
	Equipment functions – Fume cupboard control	2.1 – 46
	Equipment functions – Room control	2.1 – 51
	Specification text – Fume cupboard control	2.1 – 57
	Specification text – Room control	2.1 – 59
	Basic information and nomenclature	2.7 – 1

Description



TCU-LON-II

Application

- Electronic controller Type TCU-LON-II that meets the most demanding volume flow control requirements
- Controllers can be used individually or combined with other controllers for a complete room solution
- Integral LonWorks interface, hence particularly suitable for buildings with LonWorks infrastructure
- Fast and stable volume flow control for fume cupboards, supply air and extract air
- Fume cupboard control to EN 14175
- System solution for the volume flow control in rooms (room balance)
- Room pressure control or duct pressure control as cascade of differential pressure and volume flow rate
- Temperature control with control input signal for a reheater with LonWorks-compatible valve actuator
- Many configurable special functions allow for project-specific adjustments
- Integration of LonWorks peripheral devices such as operating and display units
- Interface to central BMS
- For use in laboratories, clean rooms in the pharmaceutical and semiconductor industries, operation theatres, intensive care units, and offices with very demanding control requirements

Equipment functions

- FH: Fume cupboard control
- RS: Supply air control (Room Supply)
- RE: Extract air control (Room Extract)
- PS: Differential pressure control – supply air (Pressure Supply)
- PE: Differential pressure control – extract air (Pressure Extract)
- Differential pressure transducers for equipment functions PS and PE are included in the supply package
- The required flow rate range must be specified at the time of ordering

Useful additions

- BE-TCU-LON-II: Fume cupboard control panel
- TCU-LON-II plug-in: Configuration software for the commissioning and diagnosis of TCU-LON-II
- LON-WA5/B, LON-WA5/B-TAG: Integration of volume flow controllers with 0 – 10 V signal into the LonWorks system

Special features

- Long-term stable volume flow rate measurement and reduced maintenance due to automatic zero point correction of the differential pressure transducer
- Temperature control with control input signal for a reheater is possible
- Consideration of diversity factors when many fume cupboards in a room are to be controlled
- Complete LonWorks interface allows for the integration of all controllers with the central BMS: central access to all controllers for data exchange, configuration, remote maintenance, standard interface with LonWorks standard network variables SNVT, two-core cable with reverse voltage protection, reduced wiring effort when compared with conventional systems that use 0 – 10 V signals for single data transmission
- Alarm signalling using relay changeover contacts
- VAV terminal units are shipped complete with ready-to-use electronic controller TCU-LON-II
- Configuration software plug-in TCU-LON-II with interactive navigation
- Factory tested and configured with project-specific parameters
- Integral power failure recognition with maintenance-free Goldcap capacitor

Parts and characteristics

- Ready-to-commission controller, as an attachment for air terminal units
- Microprocessor system with programme and system data stored in nonvolatile memory
- Fast-running high-precision actuator, running time for 90° is 3 s
- Permanent function monitoring of the system and the connected sensors
- Double-stack terminal blocks for supply voltage connection
- 2 digital inputs with clamp terminals
- 1 digital output with clamp terminals
- 1 analog output for plug-in actuator
- Analog input for plug connection (on the fume cupboard controller it is reserved for the face velocity transducer)
- LonWorks interface with double-stack terminal block
- Clamp terminals can also be used for fine wires with sleeves of up to 1.0 mm²
- Connection socket for control panel
- Static differential pressure transducer for rapid actual value measurement with automatic zero point correction

Construction features

- Factory mounted to volume flow controllers of Type TVLK, TVRK, TVR, TVA, TVZ, TVT, or TVJ
- Controller casing can be opened without tools
- Microprocessor system with neuron chip; programme and system data stored in non-volatile EEPROM
- Equipment functions can be adjusted using different software applications and parameters
- Hardware for fume cupboard control, supply air control, extract air control, differential pressure control
- Quick-response volume flow control loop with fast-running actuator
- LonWorks-FTT-10A interface for free-topology networks
- Activation of LonWorks service pin push button on the controller CPU or on the control panel
- Communication with standard network variables (SNVT)
- Static differential pressure transducer with room air induction to protect the sensor
- Automatic zero point correction of the transducer
- Integral power failure recognition
- Digital inputs for special functions
- Alarm output with relay change contact
- Analog input for sensor system, signalling
- Connection for BE-TCU-LON-II control panel (only for fume cupboard control)
- Service connection on the controller and on the control panel

Materials and surface

- Casing made of sheet steel, powder-coated, silver grey (RAL 7001)

Installation and commissioning

Design and installation of LonWorks infrastructure by the system integrator

- Design network structure and accessory components
- Determine transmission paths (binding) for controller information using the network management tool
- Install the complete network including router and terminators

Installation

- Installation orientation must be as shown on the sticker

Commissioning

- Commissioning by the system integrator
- If necessary, make adjustments using the TCU-LON-II configuration software plug-in for the network management tool

Standards and guidelines

- Type certification: Volume flow control system for fume cupboards to EN 14175

Room control with TCU-LON-II

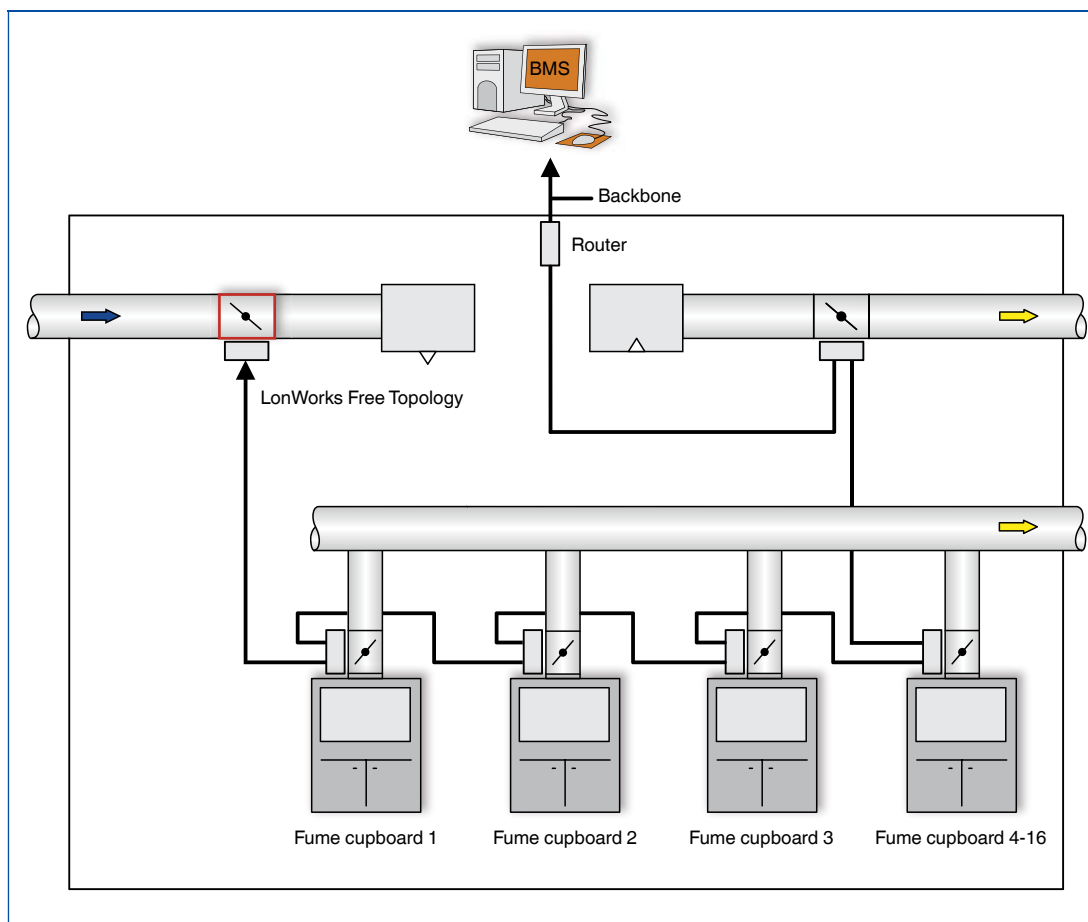

Technical data

Supply voltage	24 V AC \pm 10 %, 50 Hz
Power consumption	25 VA
Glass fuse	MT2.5 A
Operating temperature	10 – 40 °C
Switch rating of the alarm relay	250 V AC, 5 A
IEC protection class	III (protective extra-low voltage)
Protection level	IP 20
EC conformity	EMC according to 2004/108/EG
Dimensions (B x H x T)	approx. 210 x 261 x 84 mm
Weight	1.7 kg

Design fundamentals

- Connection of the controllers in a free topology network
- No more than 20 TCU-LON-II controllers per network segment (subnet), including no more than 16 fume cupboard controllers (FH)
- Additional network segments can be added via routers
- Network data cable UTB-flex 4PR AWG 26/7 Cat 5 or JY(St)Y 2 x 2 x 0.8; other types of cable must comply with the LonMark recommendations; only twisted-pair cables must be used
- Maximum length for all cables in a network segment: 500 m; greater lengths require repeaters
- Line termination within a network segment requires a terminal resistor at one end

Function

Functional description

The TCU-LON-II electronic controller was designed for sophisticated control-engineering tasks. Extensive information can be transmitted via the integral LonWorks interface. The interface reduces the wiring effort considerably when compared to the transmission of voltage and switching signals. Standard network variables (SNVT) are used for the communication within the LonWorks infrastructure. Actual values, setpoint values, operating mode default settings and alarms are transmitted as input or output variables.

The open communication facilitates the integration into a LonWorks network and with the central BMS.

The volume flow rate is determined by measuring the effective pressure. For this purpose the VAV terminal unit is fitted with an effective pressure sensor. The integral differential pressure transducer transforms the effective pressure into a voltage signal. The volume flow rate actual value is available as a network variable.

The automatic zero point correction ensures long-term stable volume flow rate measurement and reduced maintenance. The volume flow rate setpoint value is calculated based on the set operating mode (default) and on demand. The controller compares the volume flow rate setpoint value to the actual value and controls the actuator accordingly if there is a difference.

Volume flow control

- The volume flow controller works independent of the duct pressure
- Differential pressure fluctuations do not result in permanent volume flow rate changes
- To prevent the control from becoming unstable, a dead band is allowed within which the damper blade does not move.

Order code

TVLK with TCU-LON-II for fume cupboard control

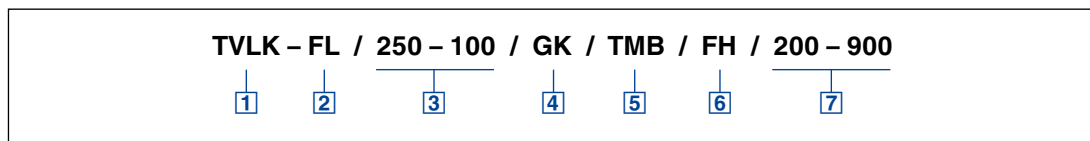

1 Type

TVLK VAV terminal unit made of plastic

2 Flange

No entry: none

FL Flanges on both ends

3 Nominal size [mm]

250 – 100 Bluff body 100

250 – 160 Bluff body 160

250 – D10 Venturi nozzle D10

250 – D16 Venturi nozzle D16

4 Accessories

No entry: none

GK Matching flanges for both ends

5 Control components

TMA TCU-LON-II with fast-running actuator

TMB TCU-LON-II with fast-running actuator
(brushless motor)

6 Equipment function

FH Fume cupboard

Face velocity control with face velocity transducer

7 Operating values [m³/h or l/s]

FH: $\dot{V}_{\min} - \dot{V}_{\max}$

Useful additions

Control panel for fume cupboard controller, for displaying the functions of the control system according to EN 14175

BE-TCU-LON-II

Order example

TVLK/250-100/TMA/FH/200-900 m³/h

Flange.....none
 Nominal size 250, with bluff body 100
 Accessoriesnone
 Control componentTCU-LON-II with fast-running actuator
 Equipment function....Fume cupboard control with face velocity transducer
 Operating values.....200 – 900 m³/h

Order code

TVR with TCU-LON-II for room control

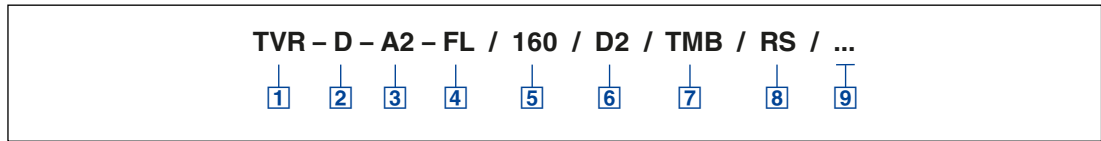

1 Type

TVR VAV terminal unit

2 Acoustic cladding

No entry: none

D With acoustic cladding

3 Material

No entry: galvanised sheet steel

P1 Powder-coated, silver grey (RAL 7001)

A2 Stainless steel

4 Flange

No entry: none

FL Both ends (not for TVR – D – P1)

5 Nominal size [mm]

100

125

160

200

250

315

400

6 Accessories

No entry: none

D2 Lip seals on both ends

GK Matching flanges for both ends

7 Control components

TMA TCU-LON-II with fast-running actuator

TMB TCU-LON-II with fast-running actuator (brushless motor)

8 Equipment function – room control

RS Room supply air

RE Room extract air

PS Differential pressure control – supply air (Pressure Supply)

PE Differential pressure control – extract air (Pressure Extract)

9 Operating values [m³/h or l/s, Pa]

Depending on equipment function:

RS: $\Delta\dot{V} / \dot{V}_{\text{constant}}$

RE: $\dot{V}_{\text{day}} / \dot{V}_{\text{night}} / \dot{V}_{\text{constant}}$

PS: $\Delta\dot{V} / \dot{V}_{\text{constant}} / \Delta p_{\text{setpoint}}$

PE: $\dot{V}_{\text{day}} / \dot{V}_{\text{night}} / \dot{V}_{\text{constant}} / \Delta p_{\text{setpoint}}$

Order example

TVR/160/TMA/RS/-100/50 m³/h

Acoustic cladding.....none

Material..... galvanised sheet steel

Flange.....none

Nominal size 160 mm

Accessoriesnone

Control componentTCU-LON-II with fast-running actuator

Equipment function Supply air controller

Operating values.....-100/50

Description

Fume cupboard control

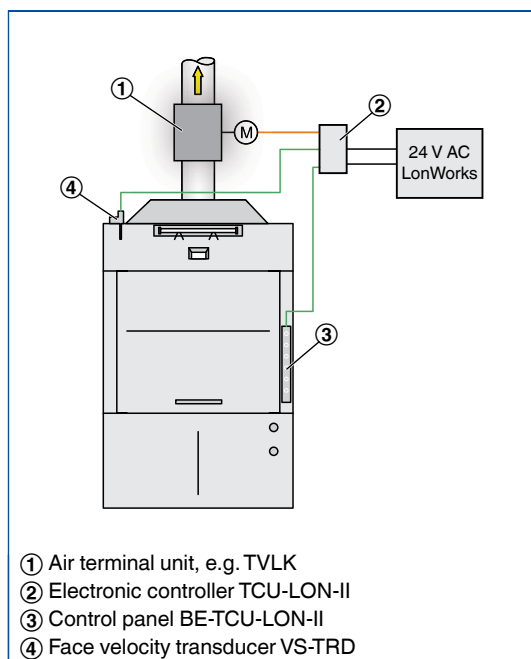

Fume cupboard control with motion detector and additional switch functions

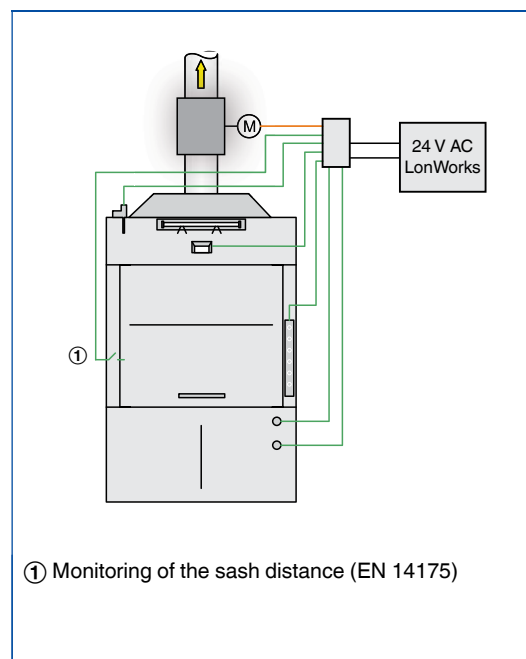

Application

- Volume flow control for fume cupboards
- Combination with plastic VAV terminal units Type TVLK or Type TVRK, or with galvanised sheet steel VAV terminal units Type TVR
- Variable volume flow control to save energy while providing maximum safety
- Control tested to EN 14175, part 6, by an independent testing institute; applies to all fume cupboards that have been tested to EN 14175
- Volume flow rate setpoint values based on fume cupboard tests to EN 14175
- Integrated monitoring of the aerodynamic function with optical and acoustic alarms according to EN 14175

Control strategies

- Variable volume flow rate control based on the measured face velocity (face velocity transducer included with the supply package)
- Non-contact measurement of the face velocity, hence not subject to wear
- Particularly suitable for fume cupboards with horizontal and vertical sashes
- Volume flow rate control with two setpoint values, controlled using a switch contact provided by others.
- Constant volume flow control control

Monitoring function

- Monitoring of the volume flow rate including configurable optical and acoustic alarms
- Optional monitoring of the face velocity, including configurable optical and acoustic alarms
- Optional monitoring of the sash distance and signalling when the sash is opened beyond the maximum operational sash opening (EN 14175)

- Optical and acoustic signalling of operating states on the BE-TCU-LON-II control panel
- Configurable alarms, e.g. duration of alarm, alarm suppression, type of signalling

Operating modes

- Standard mode (i.e. lab operation, day operation): Variable volume flow rate based on demand and on sash distance
- Reduced operation (night-time operation): Constant volume flow rate 1
- Increased operation (\dot{V}_{max} or emergency operation): Constant volume flow rate 2
- Shut-off mode
- OPEN position

Increased operation can also be activated using the control panel on the fume cupboard controller. Activation on the control panel overrides all other operating mode settings; it is possible to enter a time limit for the new operating mode.

Operating mode default setting

- Usually from the central BMS with LonWorks variables on a room controller (master)
- Operating mode default setting can affect all controllers in a room or a single controller, e.g. 24-hour operation
- Operating mode default setting is also possible using switch contacts on the controller

Maintenance

- According to the German institution for statutory accident insurance and prevention in the chemical industry (BG Chemie), fume cupboard controllers are subject to maintenance once per year.

- Special functions**
- Support of fume cupboards with supportive flow technology
 - Connection of a motion sensor to signal 'sash open' or to reduce the face velocity when nobody is working at the fume cupboard
 - Application of diversity factors in connection with TCU-LON-II room controllers

- Interfaces**
- Inputs
- 1 analog input for the face velocity transducer
 - 2 digital inputs for special functions
- Outputs
- 1 digital output for alarm signalling
- Interface to central BMS
- LonWorks data points as standard network variables (SNVT) for detailed data exchange

Input variables

SNVT parameters for TCU-LON-II as fume cupboard controller

Name of variable	Data type	Unit	Usage
nviMode	SNVT_state		Operating mode default setting
nviMode_prio	SNVT_switch		DI (state=0) or nviMode (state=1) has priority

Output variables

SNVT parameters for TCU-LON-II as fume cupboard controller

Name of variable	Data type	Unit	Usage
nvoMode_FB	SNVT_state		Signalling of operating mode default setting
nvoMode_act	SNVT_state		Output of operating mode
nvoState	SNVT_state		Display of status and fault messages
nvoAlarm_V	SNVT_switch		Output for volume flow rate alarm
nvoV_set	SNVT_flow	l/s	Volume flow rate setpoint value
nvoV_act	SNVT_flow	l/s	Volume flow rate actual value
nvoVeloc_act	SNVT_speed_mil	m/s	Face velocity actual value
nvoVeloc_set	SNVT_speed_mil	m/s	Face velocity setpoint value

Control diagrams

/ FH /

Order code detail

Face velocity control

- Variable volume flow control based on the measured face velocity
- Constant face velocity in a working range between \dot{V}_{min} and \dot{V}_{max}
- High thermal loads are detected and dissipated by an increased volume flow rate
- Non-contact measurement
- For fume cupboards with horizontal and vertical sashes

Two switching steps

- Volume flow control with two setpoint values
- Switching with a switch contact (to be provided by others)

Volume flow rate constant value

- Volume flow control with a constant setpoint value

Control diagram for face velocity

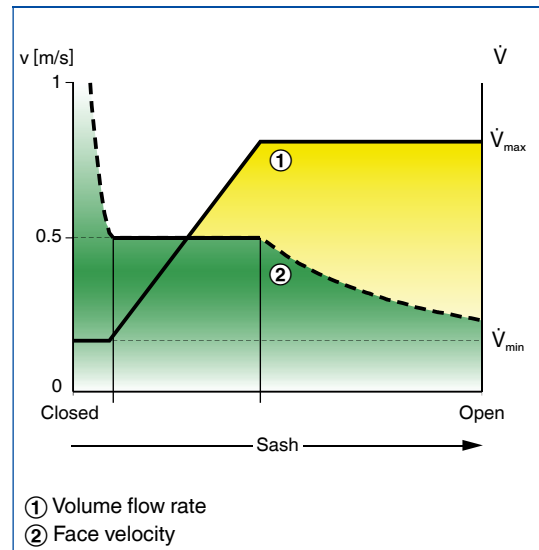

Control diagram with two switching steps

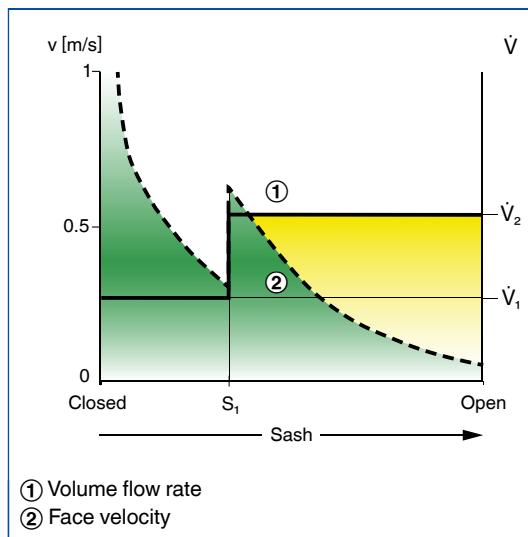

Control diagram for volume flow rate constant value

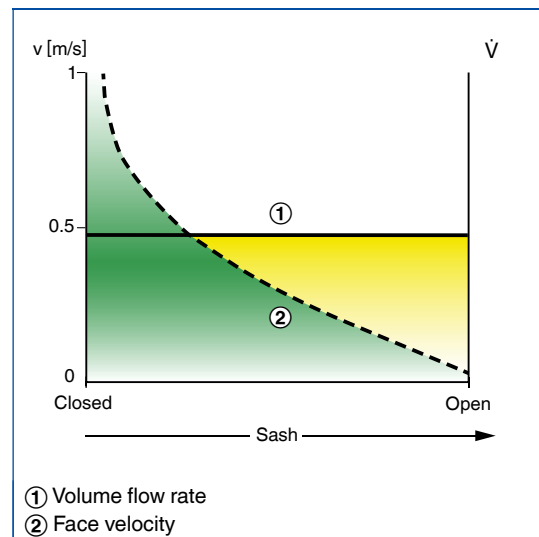

Diversity control

- In many large laboratories the simultaneous operation of all controllers at maximum power is either not desirable or not possible because of the limited capacity of the system
- It is therefore not usually possible to operate all controllers simultaneously at maximum power
- Diversity control allows for the safe and economical operation of such systems
- The total extract air flow rate is monitored; if it is not sufficient, an optical and/or acoustic alarm may be emitted
- The total extract air flow rate is monitored and, when exceeded, limited by a reduction of the volume flow rate of individual fume cupboards

Diversity control

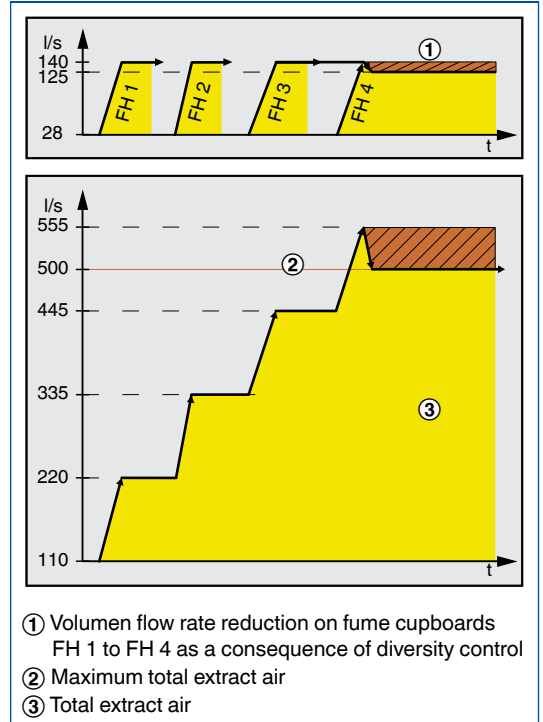

2

Measurement

Measurement location of the face velocity transducer (FH-VS, FH)

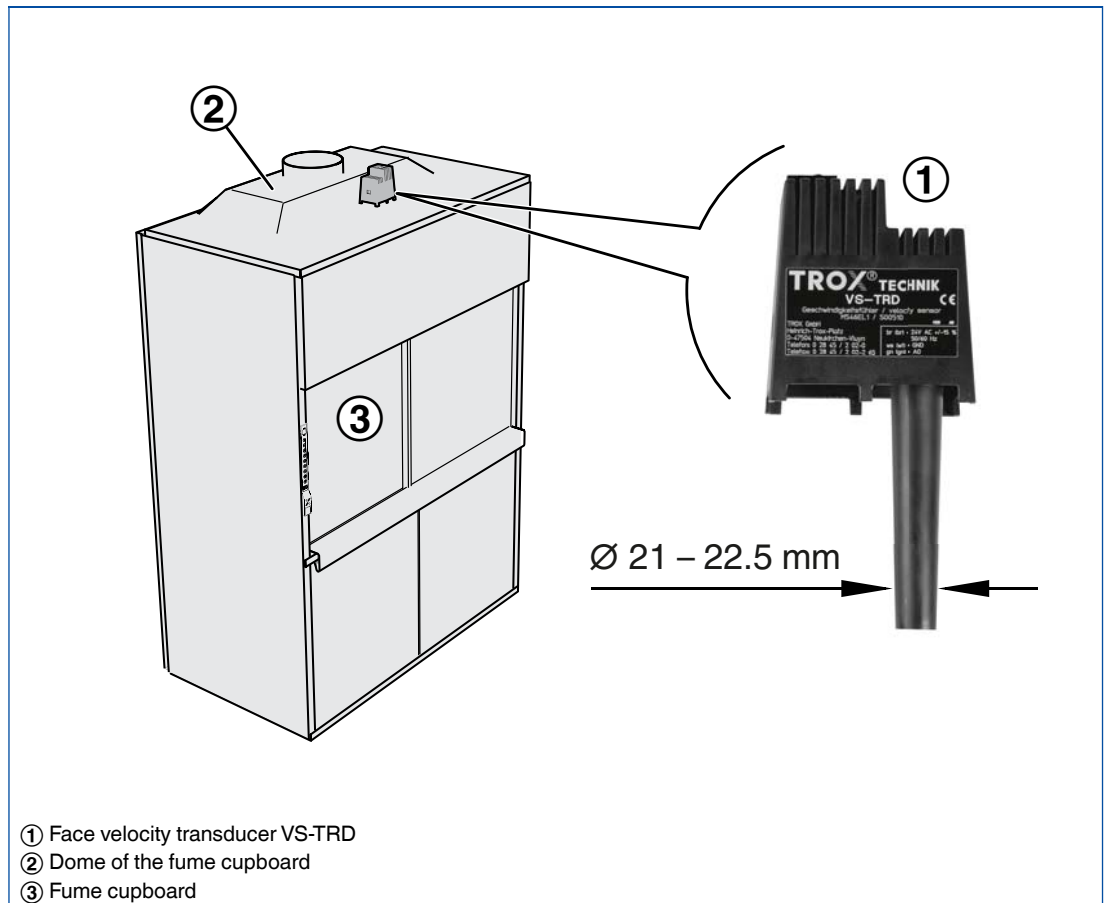

Operation

Control panel BE-TCU-LON-II

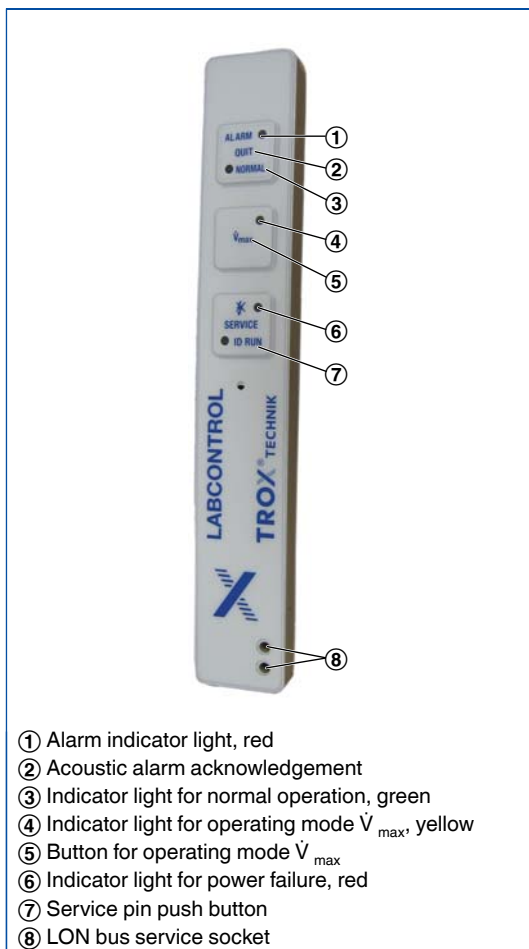

Optional motion detector

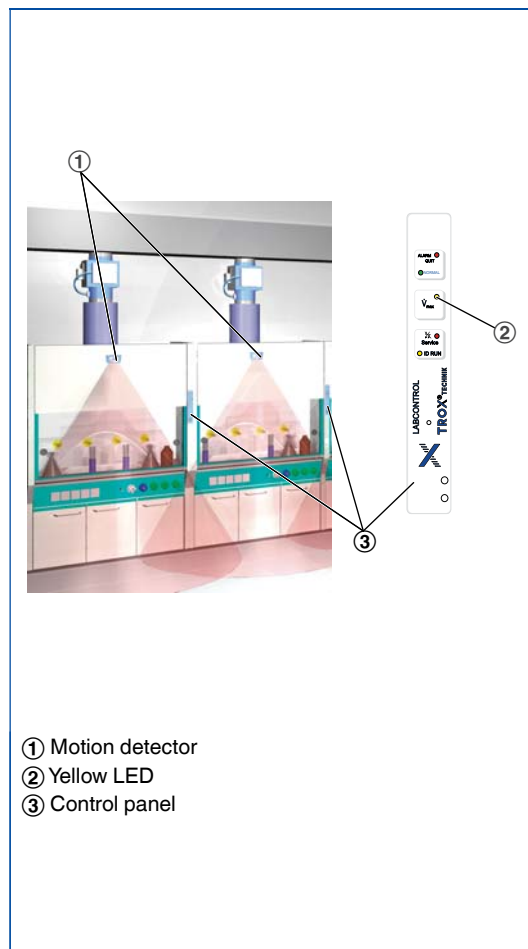

Description

Room control with TCU-LON-II

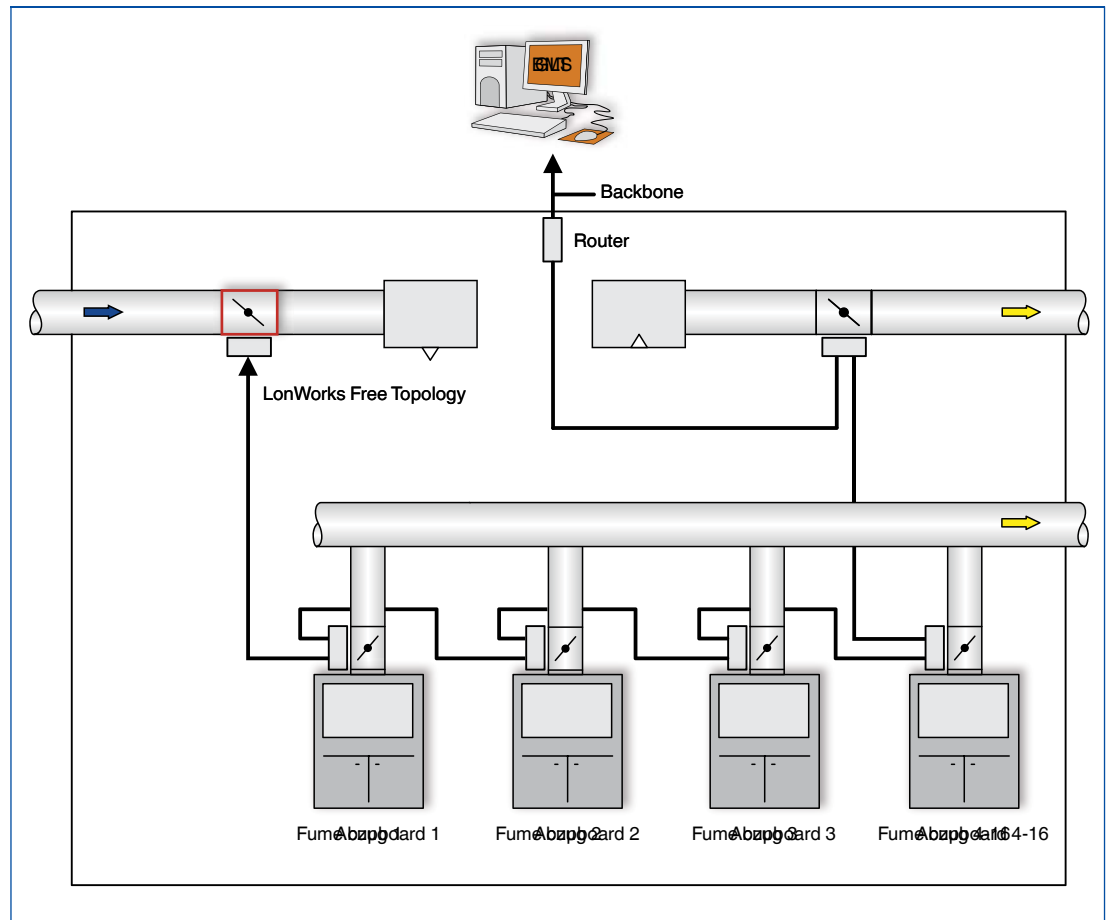

2

Application

- Variable supply air or extract air flow control for areas where quick-response and stable control is required, e.g. laboratories, clean rooms, hospital wards, and offices with demanding requirements
- Can be combined with VAV terminal units Type TVR, TVRK, TVJ, TVT, TVZ, or TVA
- Volume flow rate balancing for connected supply air and extract air flows
- For balancing, the volume flow rate actual values of up to 16 fume cupboards, room controllers or other connected extract air flows are signalled to the room controller via the LonWorks network
- Optional differential pressure control
- Using the same electronic controllers for room supply air, room extract air and fume cupboards ensures fast volume flow rate adjustment for all operating situations and hence a stable room balance
- This is all the more important as rooms are increasingly insulated to comply with fire protection requirements
- Temperature and room differential pressure can be signalled within the network; in addition, temperature, room differential pressure or other control components can be connected to an analog input

Operating modes

- Standard mode (i.e. lab operation, day operation): Variable volume flow rate based on demand and on sash distance
- Reduced operation (night-time operation): Constant volume flow rate 1
- Increased operation (\dot{V}_{max} or emergency operation): Constant volume flow rate 2
- Shut-off mode
- OPEN position

Operating mode default setting

- Usually from the central BMS with LonWorks variables on a room controller (master)
- Operating mode default setting can affect all controllers in a room or a single controller, e.g. 24-hour operation
- Operating mode default setting is also possible using switch contacts on the controller

Special functions

Integration of volume flow rates into the room balance:

- A variable volume flow can be integrated as voltage signal 0 – 10 V DC, e.g. for extraction arms or fume hoods; the characteristic for voltage signal and volume flow can be individually configured
- A constant volume flow can be integrated as switching signal, e.g. switched extraction arms or fume hoods, switching input 1 or 2 as well as the constant volume flow can be individually configured
- A permanently constant volume flow can be integrated, e.g. a CAV controller Type RN or EN; the constant volume flow rate can be individually configured

Interfaces

Inputs

- 1 analog input for special functions
- 2 digital inputs for special functions

Outputs

- 1 digital output for alarm signalling

Interface to central BMS

- LonWorks data points as standard network variables (SNVT) for detailed data exchange

Input variables

SNVT parameters for TCU-LON-II as room controller

Name of variable	Data type	Unit	Usage
nviMode	SNVT_state		Operating mode default setting
nviMode_prio	SNVT_switch		DI (state=0) or nviMode (state=1) has priority
nviV_act_01	SNVT_flow	l/s	Volume flow rate actual value 01
nviV_act_02	SNVT_flow	l/s	Volume flow rate actual value 02
nviV_act_03	SNVT_flow	l/s	Volume flow rate actual value 03
nviV_act_04	SNVT_flow	l/s	Volume flow rate actual value 04
nviV_act_05	SNVT_flow	l/s	Volume flow rate actual value 05
nviV_act_06	SNVT_flow	l/s	Volume flow rate actual value 06
nviV_act_07	SNVT_flow	l/s	Volume flow rate actual value 07
nviV_act_08	SNVT_flow	l/s	Volume flow rate actual value 08
nviV_act_09	SNVT_flow	l/s	Volume flow rate actual value 09
nviV_act_10	SNVT_flow	l/s	Volume flow rate actual value 10
nviV_act_11	SNVT_flow	l/s	Volume flow rate actual value 11
nviV_act_12	SNVT_flow	l/s	Volume flow rate actual value 12
nviV_act_13	SNVT_flow	l/s	Volume flow rate actual value 13
nviV_act_14	SNVT_flow	l/s	Volume flow rate actual value 14
nviV_act_15	SNVT_flow	l/s	Volume flow rate actual value 15
nviV_act_16	SNVT_flow	l/s	Volume flow rate actual value 16
nviPress_set	SNVT_press_p	Pa	External default setting of room pressure setpoint value
nviPress_act	SNVT_press_p	Pa	External default setting of room pressure actual value
nviTemp_set	SNVT_temp_p	°C	External default setting of room temperature setpoint value
nviTemp_act	SNVT_temp_p	°C	External default setting of room temperature actual value
nviV_offset	SNVT_switch	%	External default setting of volume flow rate setpoint change

Output variables

SNVT parameters for TCU-LON-II as room controller

Name of variable	Data type	Unit	Usage
nvoMode_FB	SNVT_state		Signalling of operating mode default setting
nvoMode_act	SNVT_state		Output of operating mode
nvoState	SNVT_state		Display of status and fault messages
nvoAlarm_1	SNVT_switch		Configurable alarm output 1
nvoAlarm_2	SNVT_switch		Configurable alarm output 2
nvoAlarm_3	SNVT_switch		Configurable alarm output 3
nvoV_set	SNVT_flow	l/s	Volume flow rate setpoint value
nvoV_act	SNVT_flow	l/s	Volume flow rate actual value
nvoPress_set	SNVT_press_p	Pa	Room pressure setpoint value
nvoPress_act	SNVT_press_p	Pa	Room pressure actual value
nvoTemp_set	SNVT_temp_p	°C	Room temperature setpoint value
nvoTemp_act	SNVT_temp_p	°C	Room temperature actual value
nvoV_AI_act	SNVT_flow	l/s	Volume flow rate actual value at analog input
nvoV_total_sup	SNVT_flow	l/s	Total supply air flow rate
nvoV_total_exh	SNVT_flow	l/s	Total extract air flow rate
nvoAct_pos	SNVT_lev_percent	%	Temperature control signal for the valve actuator

Control diagrams

/ RS / ...

Order code detail

Supply air control for equipment function RS

- Control of the demand-based supply air flow rate which results from the actual total extract air flow for the room
- This strategy takes a user-defined difference into account in order to maintain the negative pressure in compliance with DIN 1946, part 7
- Other volume flow rate signals, e.g. signals from volume flow controllers with 0 – 10 V output, can be incorporated into the LonWorks network using modules such as the LON-WA-5B

Control diagram for supply air control

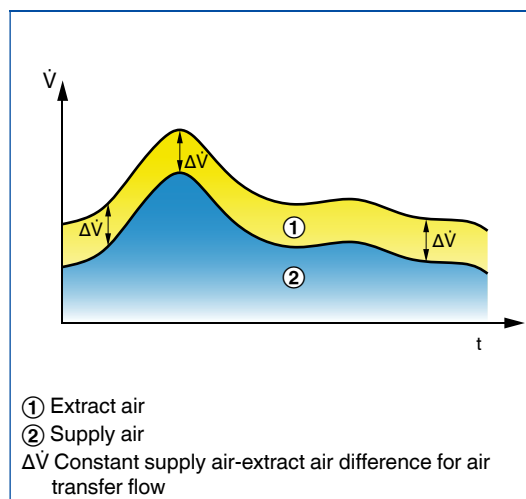

/ RE / ...

Order code detail

Extract air control for equipment function RE

- Control of the room extract air and limitation of the total extract air flow rate of the room
- If the total extract air flow rate is not sufficient, the room extract air is controlled accordingly

Volume flow rates from fume cupboard controllers and extract air controllers are incorporated

- Connection of variable flows as network variables
- Connection of variable flows as voltage signal
- Connection of constant volume flow rates as switch contact
- Pre-configured constant volume flow rates

Control diagram for extract air control

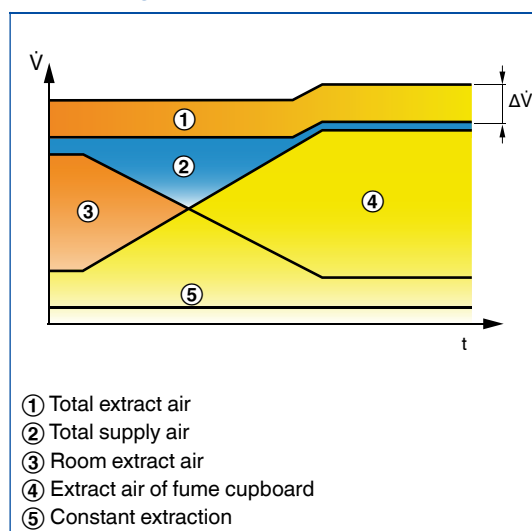

/ RE /

Order code detail

External temperature control

- Connection of a volume flow rate setpoint change from a room temperature controller (supplied by others)
- Voltage signal 0 – 10 V DC with configurable characteristic or LonWorks input variable
- The volume flow rate of the controller is increased according to the setpoint change signal
- If the volume flow rate setpoint change is connected to the extract air controller the supply air flow rate will also be adapted since the control loops maintain the set room balance
- This effect can be used for room temperature control

Internal room temperature control

- Connection of room temperature with temperature sensor (to be provided by others)
- Voltage signal 0 – 10 V DC with configurable characteristic or LonWorks input variable
- The setpoint value can be set (configuration) or signalled
- Voltage signal 0 – 10 V DC with configurable characteristic or LonWorks input variable
- The TCU-LON-II controller compares the actual value with the setpoint value and alters the volume flow rates if there is a difference between the two values
- Summer/winter changeover for cooling or heating can be switched at a digital input
- Control input signal for reheater using a LonWorks output variable (valve actuator with LonWorks interface)

Note

- The number of digital and analog inputs of the TCU-LON-II controller may affect (limit) the combination options for the described special functions
- It may be possible to use equivalent LonWorks variables as alternatives
- The extract air controller is typically used for external and internal temperature control

Control diagram for extract air control with volume flow rate setpoint change

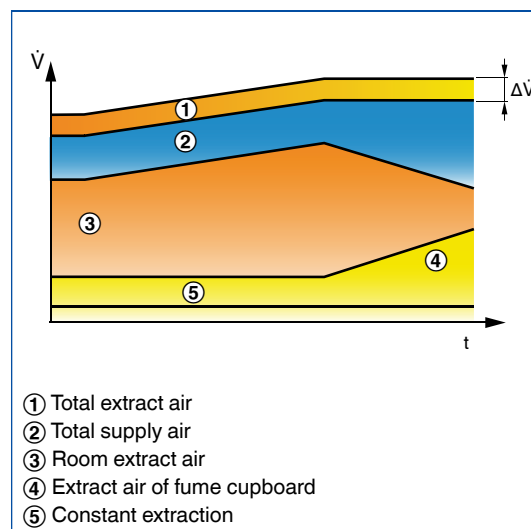

Control diagrams

/ PS / ...
/ PE / ...

Order code detail

Differential pressure control for equipment function PS (supply air) or PE (extract air)

- Linkage of room balancing and room pressure control
- Room balance control combined with differential pressure control to quickly achieve a balanced and stable pressure
- Individual extract air volume flow rates are recorded and signalled to the room controller
- The necessary room extract or room supply air is then balanced on the room controller
- Room pressure actual value as a cascade
- The required room pressure is ensured by varying the difference between supply air and extract air
- The setpoint value can be set (configuration) or signalled
- Voltage signal 0 – 10 V DC with configurable characteristic or LonWorks input variable
- Positive and negative pressure can be connected to the same digital input
- Negative pressure (for laboratories) is typically controlled by the supply air controller; positive pressure (for clean rooms) is typically controlled by the extract air controller

Note

- Connection options for the pressure actual value: Voltage signal 0 – 10 V DC with configurable characteristic or LonWorks input variable
- Differential pressure and temperature cannot be controlled with the same controller
- Differential pressure transducers for equipment functions PS and PE are included in the supply package; the volume flow rate range must be specified with the order

Control diagram for differential pressure control

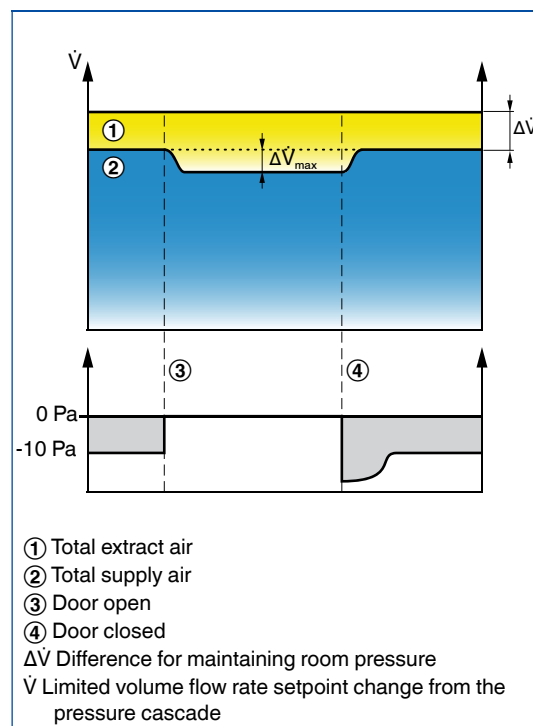

Standard text

This specification text describes just one variant of the product that applies to many applications. Texts for other variants can be generated with our Easy Product Finder design programme.

Circular VAV terminal units made of polypropylene (PPs), for variable air volume systems and fume cupboards. Suitable for the control of extract air containing aggressive media since all components coming into contact with the airflow are made of plastic (no interior metal parts).

Ready-to-operate unit consists of the mechanical parts and the electronic control components. Each unit contains a damper blade and an averaging effective pressure sensor with bluff body or a Venturi nozzle for volume flow rate measurement. Factory-assembled control components complete with wiring and tubing. Differential pressure sensor with 3 mm measuring holes, thus resistant to dust and pollution. Spigot connections suitable for circular connecting ducts to DIN 8077.

Position of the damper blade indicated externally at shaft extension. Closed blade air leakage to EN 1751, class 4. Casing air leakage to EN 1751, class C.

Technical data

- Nominal sizes: 250 mm
- Volume flow rate range: 30 to 360 l/s or 108 to 1296 m³/h
- Volume flow rate control range: approx. 15 to 100 % of the nominal volume flow rate
- Differential pressure: 5 – 1000 Pa

Control component

Electronic controller for the demand-based control of variable volume flow rates of fume cupboards including the integrated monitoring of the aerodynamic function according to EN 1415 with optical and acoustic signalling.

Non-contact measurement of the face velocity and direction using a separate transducer without mechanical recording of the sash position (no wear and tear as there are no moving parts), automatic detection of thermal loads in the fume cupboard, and increase of the volume flow rate in order to safely dissipate thermal loads. Increased operation (\dot{V}_{max}) independent of the sash position can be switched using, for example, the control panel.

Variable fume cupboard control with non-contact capturing of the sash distance based on the measured face velocity and detection of thermal loads

General features – Control component

- Electronic control components installed on and wired to the air terminal unit at the factory
- Control electronics using a microprocessor, with configuration settings stored in EEPROM memory and thus safe in case of a power failure
- Integrated system and sensor monitoring
- Supply voltage 24 V AC \pm 15 %
- LonWorks communication system FTT-10A: Only standard network variables (SNVT) are used for the communication with room extract air controllers, room supply air controllers, and

- the central BMS, i.e. actual values, setpoint value, fault signals, and status messages
- Integral static differential pressure transducer for the volume flow rate measurement, with room air induction to protect the measurement point, with cyclic automatic zero point correction
- Maintaining of the volume flow rates through a permanent setpoint/actual value comparison in a closed loop with a limitation to minimum and maximum volume flow rates.
- Fast-running actuator (actuation time $90^\circ < 3$ s)
- Configuration, commissioning and diagnosis within the LonWorks network using software plug-ins for the network management tool; remote access is also possible
- Factory set project-specific configuration and aerodynamic testing

Special features – Fume cupboard control

- Face velocity transducer with plug-in cable; simple installation by inserting it into a 21 – 22.5 mm drilled hole in the dome of the fume cupboard; voltage supplied by the controller
- Integrated monitoring of the aerodynamic function, i.e. volume flow rate and/or face velocity; optical and acoustic alarms
- Monitoring and signalling of the maximum sash opening according to EN 14175; acoustic signalling can be switched off or the duration can be limited
- Connection for control panel
- Operating mode default setting by the central BMS and switch contacts (increased operation, standard operation, reduced operation, shut-off, and open position of the damper blade) or from the fume cupboard control panel (increased operation, standard operation)
- Alarm parameters can be set. Alarm sound can be deactivated or the duration can be limited
- Power failure is displayed on the control panel (maintenance-free capacitor buffer)
- Application of diversity factors in connection with room controllers
- Integration of constant volume flow rates in the room balance using switch contacts or constant values
- Support of fume cupboards with supportive flow technology
- Ready to integrate motion detectors
- Reduction of the face velocity when no motion is detected at the fume cupboard; optical and acoustic signal as a prompt to close the sash to save energy

Inputs

- LonWorks standard network variables for operating mode default settings
- 1 analog input to connect a face velocity transducer
- 2 volt-free digital inputs to integrate constant volume flow rates or to signal operating modes, or to activate special functions

Outputs

- LonWorks standard network variables for actual and setpoint values, fault signals, and status messages
- 1 digital switch output (relay change contact) to signal fault messages; depending on the various operating modes the signalling can be configured, i.e. it is possible to suppress it for certain operating modes (reduced operation, shut off, damper blade open)
- 1 analog output to control the actuator

Technical data

- LonWorks interface FTT-10A (Free Topology Twisted Pair) with double stack terminal block to facilitate network wiring
- Integral static differential pressure transducer, 0 – 300 Pa, with automatic zero point correction
- Supply voltage 24 V AC, ± 10 %, 50 Hz
- Power consumption 25 VA
- Temperature range 10 – 40 °C
- Protection level IP 20

Order options

TVR with EASYLAB

1 Type

TVLK VAV terminal unit made of plastic

2 Flange

No entry: none

FL Flanges on both ends

3 Nominal size [mm]

- 250 – 100** Bluff body 100
- 250 – 160** Bluff body 160
- 250 – D10** Venturi nozzle D10
- 250 – D16** Venturi nozzle D16

4 Accessories

No entry: none

GK Matching flanges for both ends

5 Control components

- TMA** TCU-LON-II with fast-running actuator
- TMB** TCU-LON-II with fast-running actuator (brushless motor)

6 Equipment function

- FH** Fume cupboard
- Face velocity control with face velocity transducer

7 Operating values [m³/h or l/s]

FH: $\dot{V}_{\min} - \dot{V}_{\max}$

Useful additions

Control panel for fume cupboard controller, for displaying the functions of the control system according to EN 14175

BE-TCU-LON-II

Standard text

This specification text describes just one variant of the product that applies to many applications. Texts for other variants can be generated with our Easy Product Finder design programme.

Circular VAV terminal unit for variable and constant volume air flow systems, suitable for supply or extract air, available in 7 nominal sizes. High control accuracy (even with upstream bend $R = 1D$). Ready-to-operate unit consists of the mechanical parts and the electronic control components. Each unit contains an averaging effective pressure sensor for volume flow rate measurement, and a control damper blade. Factory-assembled control components complete with wiring and tubing. Differential pressure sensor with 3 mm measuring holes, thus resistant to dust and pollution. Spigot connections with groove for lip seal; suitable for circular connecting ducts to EN 1506 or EN 13180. Position of the damper blade indicated externally at shaft extension. Closed blade air leakage to EN 1751, class 4 (nominal size 100, class 2; nominal sizes 125 and 160, class 3). Casing air leakage to EN 1751, class C.

Technical data

- Nominal sizes: 100 to 400 mm
- Volume flow rate range: 10 to 1680 l/s or 36 to 6048 m³/h
- Volume flow rate control range (unit with dynamic effective pressure measurement): approx. 10 to 100 % of the nominal volume flow rate
- Differential pressure : 20 – 1500 Pa

Control component

Electronic control system for the demand-based variable volume flow control of supply or extract air and depending on the room settings and the actual room balance.

Control strategy

- Room supply air controller (RS) controls the difference between the total extract air flow rate actual value and the setpoint value
- Switched variable volume flows and the parameters for the constant volume flow rates are taken into consideration
- The differential pressure and the direction of the transfer flow can be set

General features – Control component

- Electronic control components installed on and wired to the air terminal unit at the factory
- Control electronics using a microprocessor, with configuration settings stored in EEPROM memory and thus safe in case of a power failure
- Integrated system and sensor monitoring
- Supply voltage 24 V AC \pm 15 %
- LonWorks communication system FTT-10A: Only standard network variables (SNVT) are used for the communication with fume cupboard controllers, room supply air controllers, and the central BMS, i.e. actual values, setpoint value, fault signals, and status messages are signalled
- Integral static differential pressure transducer for the volume flow rate measurement, with room air induction to protect the measurement point, with cyclic automatic zero point correction

- Independent of the duct pressure the maintaining of the volume flow rates through a permanent setpoint/actual value comparison in a closed loop and limitation to minimum and maximum volume flow rates
- Fast-running actuator (actuation time $90^\circ < 3$ s)
- Configuration, commissioning and diagnosis within the LonWorks network using software plug-ins for the network management tool; remote access is also possible
- Factory set project-specific, electric and aerodynamic testing

Special features – Room control (supply air/ extract air)

- Operating mode defaults are set by the central BMS or provided using switch contacts
- Integration of volume flows into the room balance: Up to 16 variable volume flows can be integrated using network variables, 1 constant extract air flow can be integrated with a switch contact, and 1 variable volume flow can be integrated with an analog signal
- Alarm functions can be configured
- Optional room temperature control by signalling a flow rate setpoint change or by internal control using a temperature signal
- Diversity control is possible if there are several fume cupboards per room or zone: 1 – If a volume flow rate limit is exceeded, an alarm is signalled to the network and relay output; 2 – If a volume flow rate limit is exceeded, a signal to reduce the volume flow is sent to the fume cupboard controller

Inputs

- LonWorks standard network variables for operating mode default settings
- 1 analog input for connecting a volume flow, a temperature value (temperature control), or a temperature controller (setpoint change signal)
- 2 volt-free digital inputs to integrate constant volume flow rates or to signal operating modes, or to activate special functions

Outputs

- LonWorks standard network variables for actual and setpoint values, fault signals, and status messages
- 1 digital switch output (relay change contact) to signal fault messages; depending on the various operating modes the signalling can be configured, i.e. it is possible to suppress it for certain operating modes (reduced operation, shut off, damper blade open)
- 1 analog output to control the actuator

Technical data

- LonWorks interface FTT-10A (Free Topology Twisted Pair) with double stack terminal block to facilitate network wiring
- Integral static differential pressure transducer, 0 – 300 Pa, with automatic zero point correction
- Supply voltage 24 V AC, \pm 10 %, 50 Hz
- Power consumption 25 VA
- Temperature range 10 – 40 °C
- Protection level IP 20

Order options

TVR with EASYLAB

1 Type

- TVR** VAV terminal unit

2 Acoustic cladding

- No entry: none
 D With acoustic cladding

3 Material

- No entry: galvanised sheet steel
 P1 Powder-coated, silver grey (RAL 7001)
 A2 Stainless steel

4 Flange

- No entry: none
 FL Both ends (not for TVR – D – P1)

5 Nominal size [mm]

- 100**
 125
 160
 200
 250
 315
 400

6 Accessories

- No entry: none
 D2 Lip seals on both ends
 GK Matching flanges for both ends

7 Control components

- TMA** TCU-LON-II with fast-running actuator
 TMB TCU-LON-II with fast-running actuator (brushless motor)

8 Equipment function – room control

- RS** Room supply air
 RE Room extract air
 PS Differential pressure control – supply air (Pressure Supply)
 PE Differential pressure control – extract air (Pressure Extract)

9 Operating values [m³/h or l/s, Pa]

Depending on equipment function:

RS: $\Delta\dot{V} / \dot{V}_{\text{constant}}$

RE: $\dot{V}_{\text{day}} / \dot{V}_{\text{night}} / \dot{V}_{\text{constant}}$

PS: $\Delta\dot{V} / \dot{V}_{\text{constant}} / \Delta p_{\text{setpoint}}$

PE: $\dot{V}_{\text{day}} / \dot{V}_{\text{night}} / \dot{V}_{\text{constant}} / \Delta p_{\text{setpoint}}$

Monitoring systems

TFM-1



For the monitoring of volume flows

Monitoring system with integral static differential pressure transducer and measuring probe for fume cupboards, fume hoods and similar components of the supply air or extract air system

- Two values can be monitored, switching between the two is possible; alarms can be configured; monitoring can be switched off
- Optical and acoustic alarms are emitted on the control panel
- Control panel with lighting button that also displays power failures
- Monitoring parameters and additional functions can be adjusted using MConnect configuration software
- For new installations and for refurbishment

Alternative recording of the volume flow being monitored

- Using volume flow rate measuring unit Type VMR, VME or VMLK



Volume flow rate measuring units Type VMLK with Venturi nozzle and flange

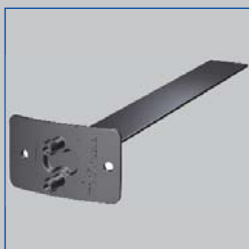

Measuring probe is part of the supply package

Type		Page
TFM-1	General information	2.2 – 2
	Specification text	2.2 – 4
	Basic information and nomenclature	2.7 – 1

Description



Fume cupboard monitoring system TFM-1

Application

- Monitoring system TFM-1 for volume flow monitoring on fume cupboards, fume hoods and similar components
- Simple solution for fume cupboards with a constant extract air flow
- Optical and acoustic alarms as well as alarm signalling to higher-level systems (central BMS)
- Measured value recording by means of a measuring probe and an integral static differential pressure transducer
- For use in laboratories, clean rooms in the pharmaceutical and semiconductor industries, operation theatres, intensive care units, and offices
- For new installations, retrofit, and refurbishment projects

The correct aerodynamic function of a fume cupboard must be monitored and displayed (EN 14175-2, for refurbishment projects DIN 12924 may apply). Any fault must be indicated by an optical and acoustic alarm. The monitoring system TFM-1 meets these requirements.

Variants

- TFM-1: Monitoring system
- TFM-1 230 V: Monitoring system with mains supply connection 230 V AC

Useful additions

- MConnect: Configuration software for on-site configuration and service

Special features

- Two values can be monitored, switching between the two is possible; alarms can be configured; monitoring can be switched off
- Signalling of normal operation, volume flow rate higher or lower than setpoint, power failure
- Control of the fume cupboard lighting from the control panel
- Service access from the control panel
- On-site configuration with free-of-charge configuration software MConnect

Parts and characteristics

- Microprocessor system with programme and system data stored in nonvolatile memory
- Static differential pressure transducer, suitable for aggressive media
- Plastic measuring probe, easy to install in the duct
- Digital inputs for special functions, can be configured as make/break contacts
- Digital outputs for alarm signalling and special functions
- Power failure indication

Control panel

- Display: Volume flow rate or differential pressure alarm, red; power failure, flashing red
- Display: Normal operation, green
- Display: Volume flow rate exceeds setpoint or differential pressure deviates from setpoint, yellow
- Alarm acknowledgement
- Alarm sounder
- Socket to connect a notebook for service and commissioning

Construction features

- Casing can be opened and closed without tools
- Control panel with plug-in connecting cable

Materials and surface

- Casing made of galvanised sheet steel, powder-coated, white
- Control panel made of plastic, light grey

Installation and commissioning

- Install measuring probe in the duct
- Install monitoring device near the volume flow rate measurement location; ensure the correct installation orientation
- Mount the control panel
- Set all monitoring parameters using MConnect
- Carry out zero point correction and functional test

Technical data

TFM-1 and TFM-1-230-V

Supply voltage	24 V AC \pm 15 %, 50/60 Hz
Supply voltage (TFM-1-230-V)	230 V AC \pm 10 %, 50/60 Hz
Power rating	3.5 VA
Measuring range, static differential pressure transducer	5 – 280 Pa
Switching signal input	3 volt-free switch contacts
Alarm output	1 volt-free change-over contact
Switching function output	3 volt-free make contacts
Operating temperature	10 – 40 °C
Switch rating of relay outputs	250 V AC, 5 A
IEC protection class	III (protective extra-low voltage)
Protection level	IP 20
EC conformity	EMC to 2004/108/EG, low voltage to 2006/95/EG
Weight	1.7 kg

Function

Functional description

The volume flow rate is determined by measuring the effective pressure. For this purpose the measuring probe is installed in the duct. Instead of a measuring probe a measuring unit can be used, e.g. Type VMLK, VMRK or VMR.

The integral differential pressure transducer transforms the effective pressure into a voltage signal. During commissioning with the MConnect configuration software a constant that depends on the duct size is saved. This constant is used for calculating the volume flow rate actual value.

The monitoring system considers a minimum volume flow rate and a maximum volume flow rate (switching, e.g. from daytime to night-time operation). Separate alarms can be configured in

case the actual flow rate exceeds the setpoint or falls short of the setpoint.

- Alarm delay
- Duration of the alarm sounding; sound can also be suppressed

Alarms can be signalled to the central BMS if the alarm relay is wired to the central BMS

Operating states are displayed on the control panel; optical and acoustic alarms are also emitted on the control panel.

Room occupants can acknowledge alarms on the control panel. Depending on the setup it might be possible to switch the fume cupboard lighting on/off from the control panel.

The monitoring function can be switched off.

Functional diagram

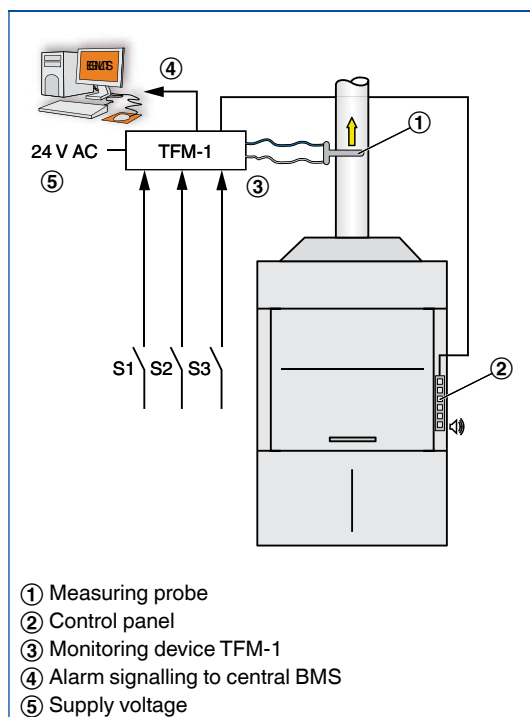

Order code

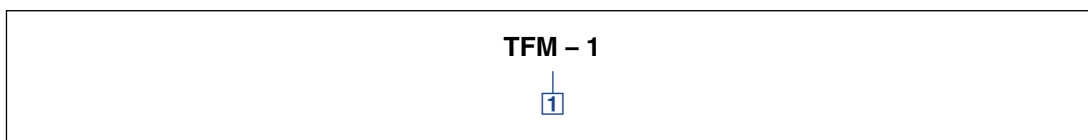

1 Type

TFM-1 Monitoring system, supply voltage 24 V AC

TFM-1-230-V Monitoring system,
supply voltage 230 V AC

Operation

Control panel for monitoring systems TFM-1 and TFM-2

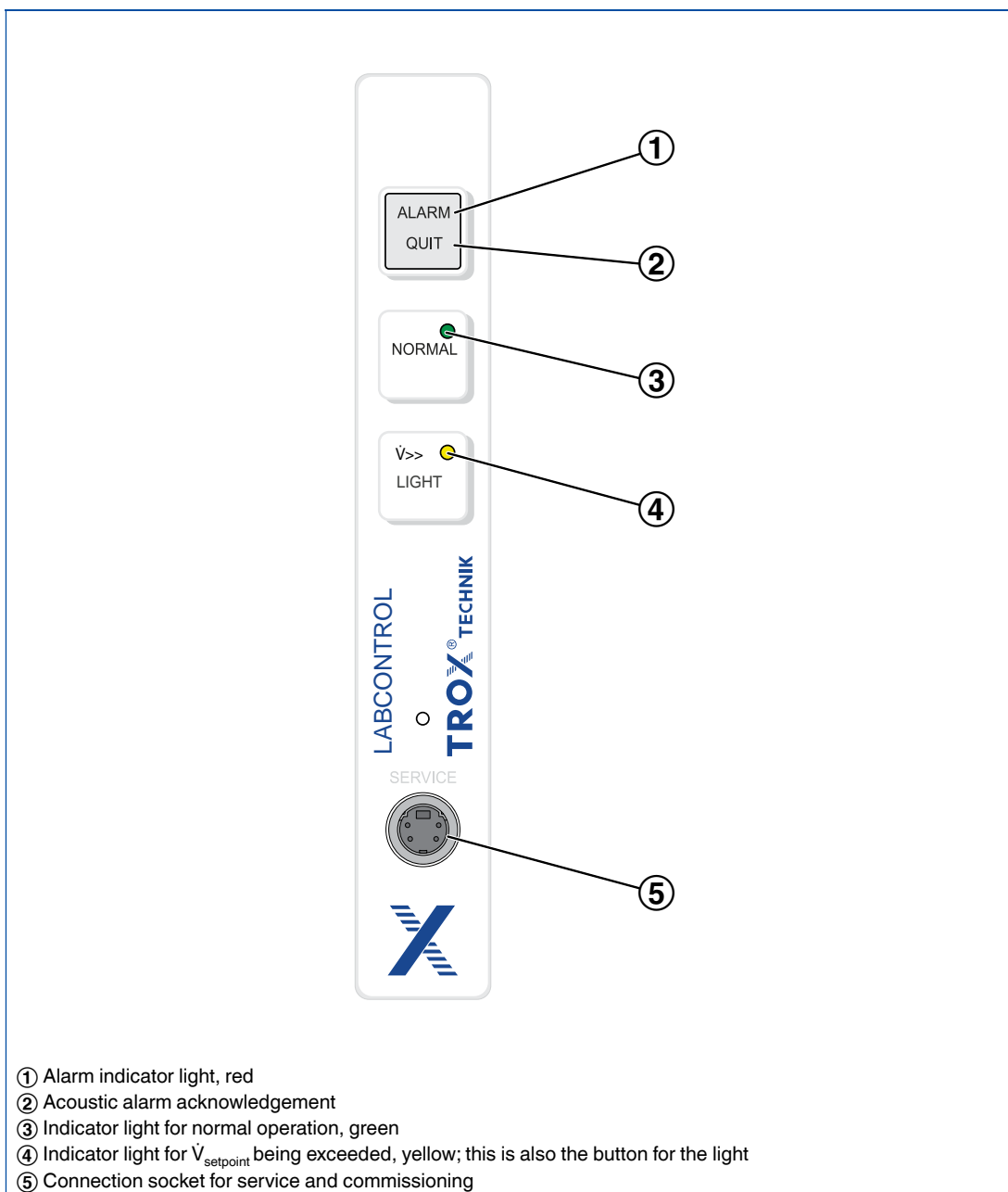

Standard text

Monitoring systems for volume flow monitoring on fume cupboards, fume hoods and similar components. Suitable for all kinds of laboratory extraction arms to EN 14175. Ready-to-use unit consists of the electronic system including a static differential pressure transducer in the same casing, a measuring probe to be installed in the ducting, a control panel, and measuring tubes. Volume flow rate monitoring of two limit values, minimum and maximum, with corresponding alarm functions that can be configured (alarm delay, duration of the alarm sounding, alarm suppression), output on a digital output. Control panel to display the operating state, to acknowledge alarms, to set special functions such as the lighting. Switching inputs for switching between the monitoring values or to switch off the monitoring function.

Special features

- Two values can be monitored, switching between the two is possible; alarms can be configured; monitoring can be switched off
- Signalling of normal operation, volume flow rate higher or lower than setpoint, power failure
- Control of the fume cupboard lighting from the control panel
- Service access from the control panel
- On-site configuration with free-of-charge configuration software MConnect

Materials and surface

- Casing made of galvanised sheet steel, powder-coated, white
- Control panel made of plastic, light grey

Technical data

- Supply voltage: 24 V AC, 50/60 Hz
- Power rating: 3.5 VA
- Measuring range, static differential pressure transducer: 5 – 280 Pa
- Switching signal: 3 volt-free switch contacts
- Alarm output: 1 volt-free change-over contact
- Switching function output: 3 volt-free make contacts

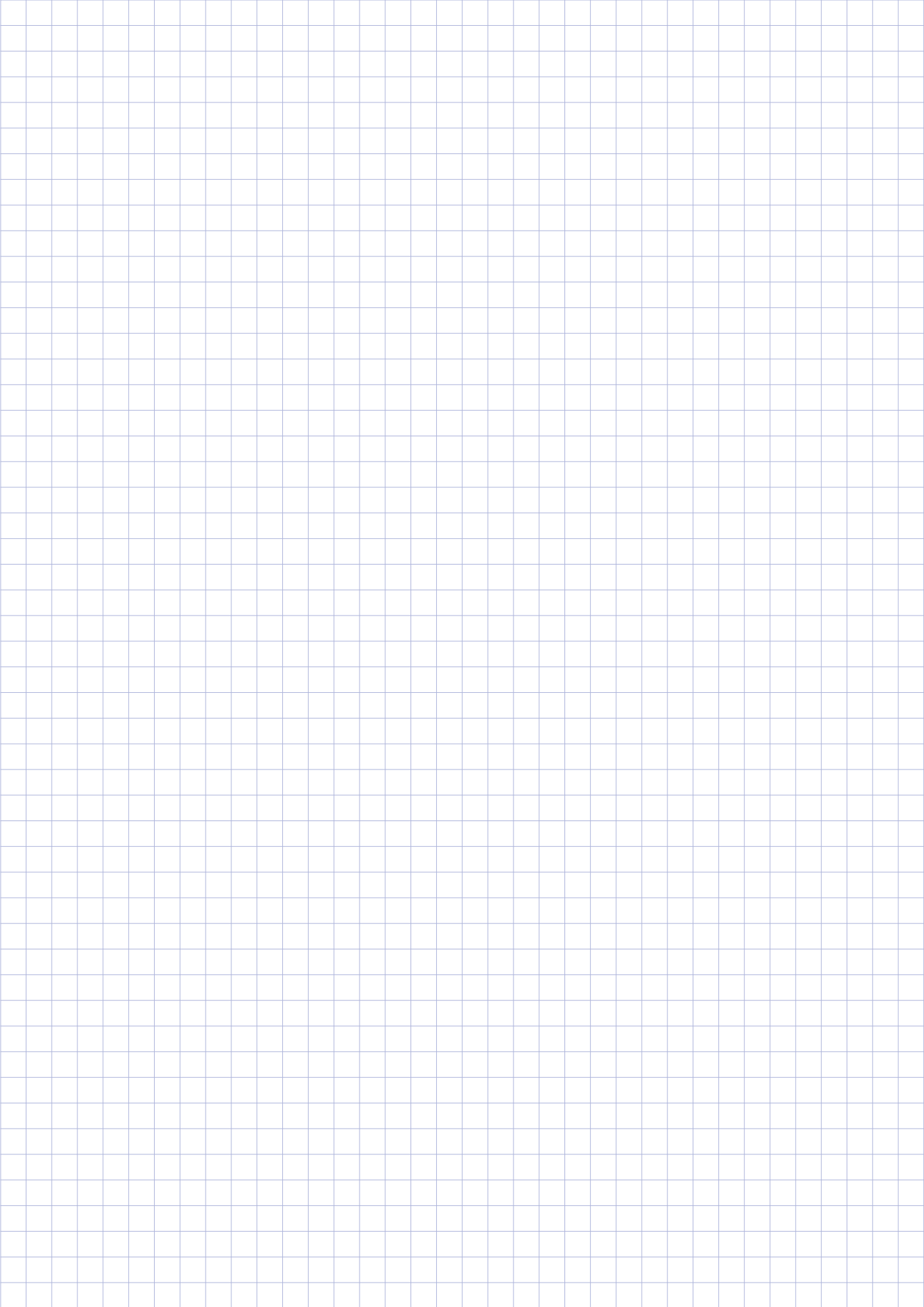

Monitoring systems

Type TFM-2-TPM



For the monitoring of differential pressure, volume flow rate or face velocity

Monitoring system for measuring variables from an external transducer

- Areas of application: Monitoring of differential pressure in rooms or ducting, of volume flow rates, and of the face velocity on fume cupboards
- Connection of voltage signals 0 – 10 V with characteristics that can be set individually
- Monitoring of two independent values; the corresponding types of alarm can be set
- Optical and acoustic alarms are emitted on the control panel
- Power failure is displayed on the control panel
- Monitoring parameters and additional functions can be adjusted using MConnect configuration software
- For new installations and for refurbishment

Recording of the measured value to be monitored

- Face velocity transducer VS-TRD
- Differential pressure transducer with voltage signal
- Volume flow rate transducer with voltage signal

Type		Page
TFM-2-TPM	General information	2.2 – 8
	Special information – TFM-2	2.3 – 10
	Special information – TPM	2.3 – 12
	Specification text	2.3 – 14
	Basic information and nomenclature	2.7 – 1

2

Description



Monitoring system
TFM-2/TPM

Application

- Monitoring devices Type TFM-2-TPM for volume flow rates, face velocity or room differential pressure with optical and acoustic alarms and alarm signalling to higher-level systems (central BMS)
- Selection of type of monitoring (volume flow rate, face velocity, differential pressure) with a single unit, configurable
- Measuring with transducers (to be provided by others) that transform measured value into an electric signal
- For use in laboratories, clean rooms in the pharmaceutical and semiconductor industries, operation theatres, intensive care units
- For new installations, retrofit, and refurbishment projects

TFM-2

- Monitoring of the volume flow rate of fume cupboards, fume hoods, extraction arms to EN 1475; as an alternative, for the monitoring of volume flow rates in ducting
- Monitoring of the face velocity for fume cupboards, fume hoods
- Electric actual value signal, for example from a volume flow controller (to be provided by others) or face velocity transducer

TPM

- Monitoring of the differential pressure in rooms or ducting
- Electric actual value signal, for example from a room pressure transducer (to be provided by others) or balance ring manometers

Useful additions

- VS-TRD: Face velocity transducer for the LABCONTROL system
- EasyConnect: Configuration software for the commissioning and diagnosis of EASYLAB components
- Differential pressure transducers: Static differential pressure transducers for room pressure control or duct pressure control

Special features

- Monitoring of volume flow rate, differential pressure or face velocity
- Measurement recording with transducer (to be provided by others) as 0 – 10 V signal
- Two values can be monitored, switching between the two is possible; alarms can be configured; monitoring can be switched off

- Optical and acoustic alarms are emitted on the control panel
- Signalling of normal operation, measured value higher or lower than setpoint, power failure
- Conventional alarm signalling (switch contact) to the central BMS
- On-site configuration with free-of-charge configuration software MConnect

Parts and characteristics

- Microprocessor system with programme and system data stored in nonvolatile memory
- Double-stack terminal blocks for supply voltage connection
- 3 digital inputs with clamp terminals
- 4 digital outputs with clamp terminals
- 1 analog input with clamp terminals
- RJ socket for control panel
- Fuse
- Integral power failure recognition with maintenance-free Goldcap capacitor

Control panel

- Display: Volume flow rate or differential pressure alarm, red; power failure, flashing red
- Display: Normal operation, green
- Display: Volume flow rate exceeds setpoint or differential pressure deviates from setpoint, yellow
- Alarm acknowledgement
- Button to switch lighting on/off (only TFM-2)
- Alarm sounder
- Socket to connect a notebook for service and commissioning

Construction features

- Casing can be opened and closed without tools
- Control panel with plug-in connecting cable

Materials and surface

- Casing made of galvanised sheet steel, powder-coated, white
- Control panel made of plastic, light grey
- Control panel with front plastic (background HKS 91 30 %, buttons and text HKS 88 30 %)

Installation and commissioning

- Install the monitoring device
- Mount the control panel
- Attach sticker for TFM-2 or TPM to the control panel
- Connect measuring transducer to the monitoring device
- Set all monitoring parameters using MConnect
- Test monitoring functions

Technical data

Supply voltage	24 V AC \pm 15 %, 50/60 Hz
Power rating	3.5 VA
Operating temperature	10 – 40 °C
Analogue input for sensor	0 – 10 V DC, characteristic can be configured
Switch rating of relays	250 V AC, 5 A
IEC protection class	III (protective extra-low voltage)
Protection level	IP 20
EC conformity	EMC to 2004/108/EG, low voltage to 2006/95/EG
Dimensions (B x H x T)	Main unit: 261 x 210,5 x 84 mm, control panel: 150 x 23 x 10 mm
Weight	1.6 kg

Order code

TFM-2-TPM

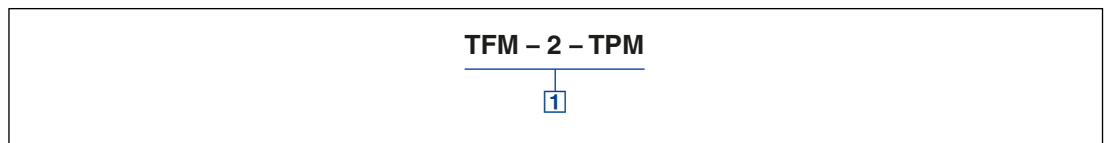

1 Type

TFM-2-TPM Monitoring system

Description

Application

- Monitoring of the volume flow rate of fume cupboards, fume hoods, extraction arms to EN 1475; as an alternative, for the monitoring of volume flow rates in ducting
- Monitoring of the face velocity for fume cupboards, fume hoods
- Electric actual value signal, for example from a volume flow controller (to be provided by others) or face velocity transducer

The correct aerodynamic function of a fume cupboard must be monitored and displayed (EN 14175-2, for refurbishment projects DIN 12924 may apply). Any fault must be indicated by an optical alarm and an alarm sound.

Function

Functional description

The volume flow rate is measured using a volume flow measuring unit or a VAV terminal unit. For face velocity monitoring a face velocity transducer can be connected.

During commissioning with the MConnect configuration software a constant that depends on the duct size is saved. This constant is used to calculate the volume flow rate actual value. The volume flow rate and differential pressure values are also set using MConnect.

The monitoring system considers a minimum value and a maximum value (switching, e.g. from daytime to night-time operation). Separate alarms

can be configured in case the actual value exceeds the setpoint or falls short of the setpoint.

- Alarm delay
- Duration of the alarm sounding; sound can also be suppressed

Alarm signalling to the central BMS can be achieved by wiring the alarm relay. The operating state is displayed on the control panel; optical and acoustic alarms are also emitted on the control panel. Room occupants can acknowledge alarms on the control panel. Depending on the setup the fume cupboard lighting can be switched on/off from the control panel. The monitoring system can be switched off.

Functional diagram

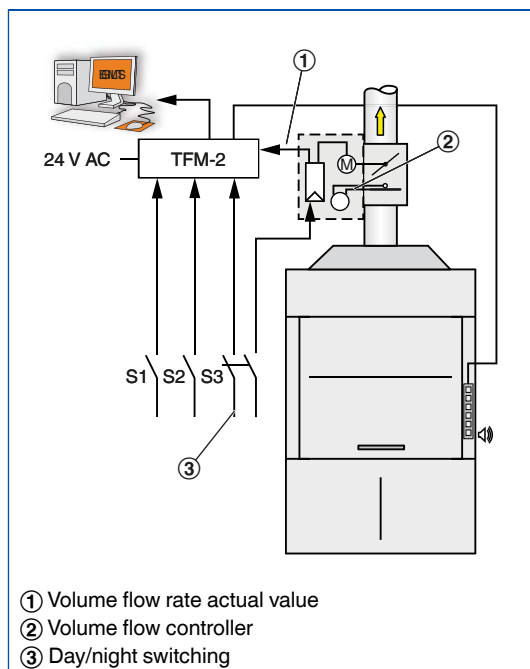

Function

Control panel for monitoring systems TFM-1 and TFM-2

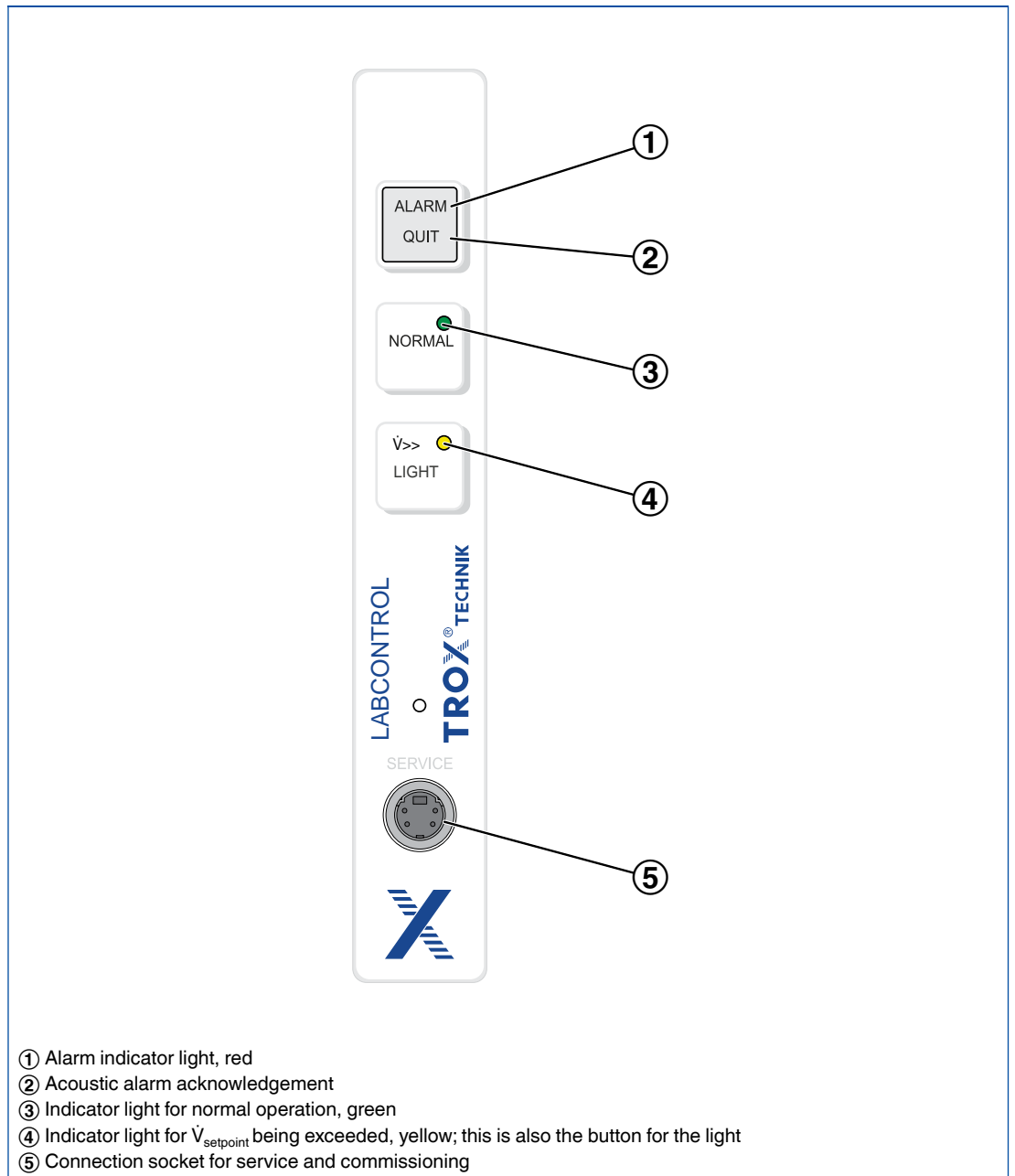

Description

Application

- Monitoring of the differential pressure in rooms or ducting
- Electric actual value signal, for example from a room pressure transducer (to be provided by others) or balance ring manometers

In many laboratory buildings or production facilities with critical safety requirements the room pressure is controlled. As the correct pressure cannot be felt, however, it should be made visible for the room occupants. The TPM is used to monitor and ensure the correct room pressure

2

Function

Functional description

The differential pressure is measured using a differential pressure transducer.

During commissioning with the MConnect configuration software the characteristic for the transducer is saved.

The monitoring system considers a minimum value and a maximum value (switching, e.g. from daytime to night-time operation). Separate alarms can be configured in case the actual value exceeds the setpoint or falls short of the setpoint.

- Alarm delay
- Duration of the alarm sounding; sound can also be suppressed

Alarm signalling to the central BMS can be achieved by wiring the alarm relay. The operating state is displayed on the control panel; optical and acoustic alarms are also emitted on the control panel. Room occupants can acknowledge alarms on the control panel. Depending on the setup the fume cupboard lighting can be switched on/off from the control panel. The monitoring system can be switched off.

Differential pressure control

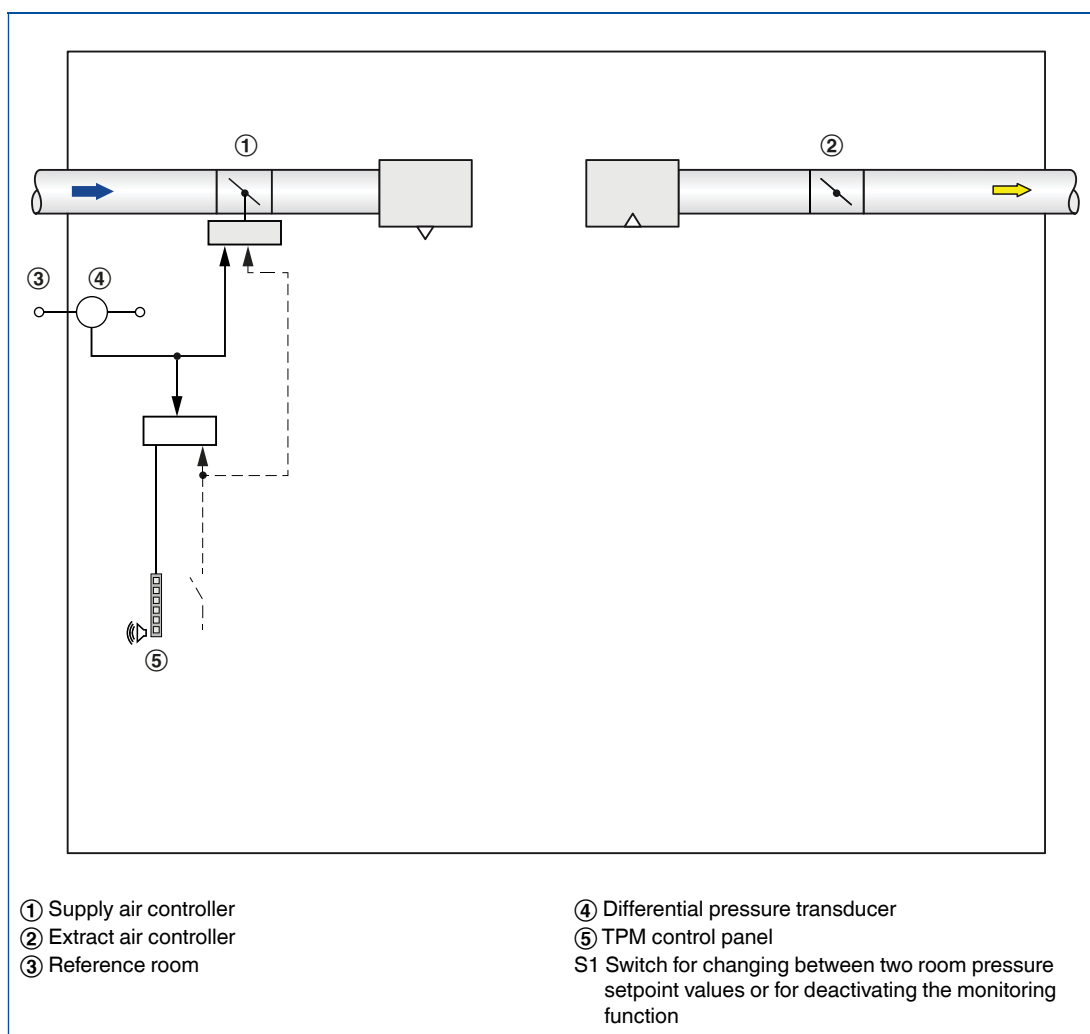

Monitoring of the room pressure

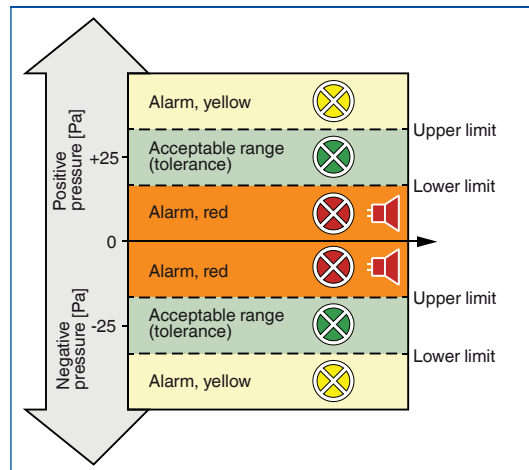

Function

TPM control panel

① Alarm indicator light, red
 ② Acoustic alarm acknowledgement
 ③ Indicator light for normal operation, green
 ④ Indicator light for differential pressure being too low, yellow; button for switching function
 ⑤ Connection socket for service and commissioning

Standard text

Monitoring devices for the monitoring of volume flow rate, room pressure, or face velocity on a fume cupboard. The quantity being monitored is received as a 0 – 10 V DC voltage signal from external transducers, e.g. face velocity transducer or volume flow measuring unit.

The monitoring system includes a microprocessor in a casing, a control panel (also for display), a sticker to mark the control panel for either volume flow rate and face velocity monitoring or for room pressure monitoring.

Special features

- Monitoring of volume flow rate, differential pressure or face velocity
- Measurement recording with transducer (to be provided by others) as 0 – 10 V signal
- Two values can be monitored, switching between the two is possible; alarms can be configured; monitoring can be switched off
- Optical and acoustic alarms are emitted on the control panel
- Signalling of normal operation, measured value higher or lower than setpoint, power failure
- Conventional alarm signalling (switch contact) to the central BMS
- On-site configuration with free-of-charge configuration software MConnect

Materials and surface

- Casing made of galvanised sheet steel, powder-coated, white
- Control panel made of plastic, light grey
- Control panel with front plastic (background HKS 91 30 %, buttons and text HKS 88 30 %)

Technical data

- Supply voltage: 24 V AC ± 15 %, 50/60 Hz
- Power rating: 3.5 VA
- Switch rating of relays: 250 V AC, 5 A

Expansion modules

EM-LON



LonWorks interface for EASYLAB controllers and adapter modules

Expansion module for EASYLAB fume cupboard controllers, room controllers and adapter modules, for the integration of rooms or individual volume flow controllers with the central BMS

- LonWorks FTT-10A interface
- Communication only using standard network variables (SNVT)
- The expansion module is fitted into the casing with the EASYLAB base component
- Easy retrofitting
- Double-stack terminals for the LonWorks network
- Service pin push button and corresponding indicator light

Interface to central BMS

- When used on a controller with active room management function (RMF) the module provides also data points for the entire room, e.g. for total volume flows or consolidated alarms
- When used on a single controller: data points for volume flow rate, alarm, damper blade position, or others
- Centralised operating mode default setting, e.g. night-time operation



LonMark Partner

Type		Page
EM-LON	General information	2.3 – 2
	Special information – individual controllers	2.3 – 4
	Special information – EASYLAB room	2.3 – 5
	Special information – LonWorks interface	2.3 – 6
	Specification text	2.3 – 18
	Basic information and nomenclature	2.7 – 1

Description



Expansion module EM-LON

Application

- Expansion module Type EM-LON for the EASYLAB system
- LonWorks FTT-10A interface to the central BMS
- Data points for individual controllers or for the room
- Room interface: Default setting of room operating modes within the EASYLAB system, increase or reduction of the air change rate, readout of the actual room operating values or evaluated damper blade positions, consolidated alarms
- Controller interface: Operating mode default setting for a single fume cupboard controller, readout of individual operating values such as volume flow rates for single controllers, or individual alarms
- Can be used with fume cupboard, supply air, extract air or differential pressure controller EASYLAB TCU3 and with adapter module TAM
- For use in laboratories, clean rooms in the pharmaceutical and semiconductor industries, operation theatres, intensive care units, and offices with very demanding control requirements
- Factory mounted or for retrofitting into the EASYLAB base component casing

Special features

- LonWorks free topology network with an arbitrary number of branches (star, line, and arbitrary combinations)
- Communication only using standard network variables (SNVT)
- Data interface for an EASYLAB controller or for an EASYLAB room with different functional profiles
- System integration (binding) into the LonWorks network is required

Parts and characteristics

- Microprocessor with basis programme stored in nonvolatile memory to load LonWorks applications
- LonWorks transceiver FTT-10A – free topology – twisted pair
- Double stack terminal block for LonWorks network (simple wiring)
- Service pin push button and corresponding indicator light for sending the Neuron ID required for system integration
- Two indicator lights to indicate 'sending data' and 'receiving data'

Construction features

- PCB dimensions and fixing points correspond to the EASYLAB main PCB and the casing
- Fixing with screws
- Pin header to connect the module to the main PCB of the TCU3 or TAM

Installation and commissioning

Installation

- As attachment for the EASYLAB base component: factory mounted
- For retrofitting: Mount the expansion module into the base casing
- Connect to the LonWorks network

Commissioning

- The EASYLAB controller identifies the expansion module automatically
- Integrate system with the LonWorks network and link the data points logically (binding) using a network management tool (e.g. Echelon LonMarker, to be provided by others)
- Load EASYLAB LonWorks application

Technical data

Supply voltage	5 V DC from controller or adapter module
Communications interface	LonWorks-Transceiver FTT-10A, free topology, twisted pair
Connection to LonWorks network	6 terminals for cable cross sections of 0.12 – 1.5 mm ² (LON A, LON B and screen, two of each)
Operating temperature	0 – 50 °C
IEC protection class	III (protective extra-low voltage)
Protection level	IP 20
EC conformity	EMC to 2004/108/EG, low voltage to 2006/95/EG
Dimensions (B × H × T)	78 × 65 × 100 mm

Function

The expansion module EM-LON supplements the EASYLAB base components (controller TCU3 or adapter module TAM) with a LonWorks interface to link rooms or individual volume flow controllers to the central BMS.

The LonWorks interface supports the EASYLAB room operating mode concept. It is possible to set operating mode defaults in order to control different volume flow rates for daytime and night-time operation; it is also possible to increase or reduce the air change rate by a certain amount (volume flow rate setpoint change), e.g. to influence the room temperature.

Using the LonWorks interface, an individual alarm management system can be set up by consolidating configurable EASYLAB alarms. The interface also enables the transfer of actual operating values such as volume flow rates and damper blade position for a controller or for all controllers in a room.

EM-LON

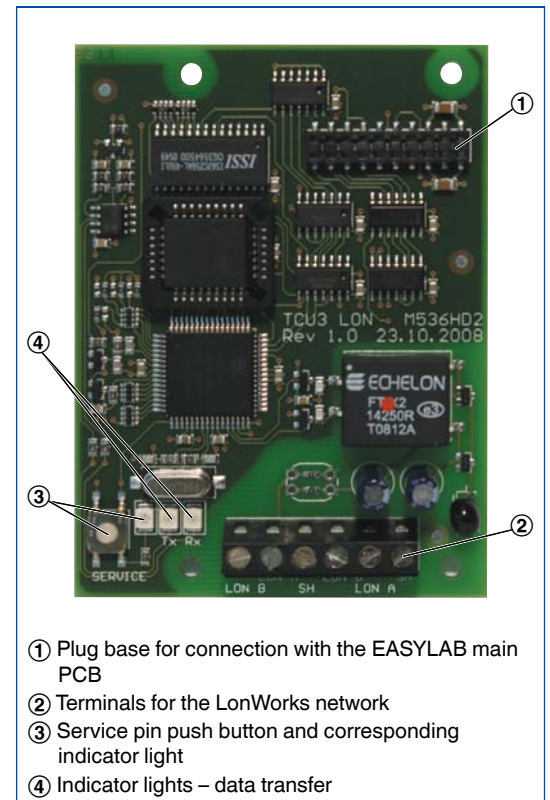

Order code

Any attachments must be defined with the order code of the VAV terminal unit.

Order code detail for control component ELAB (TCU3) or TAM

ELAB / ...L... / ...

Retrofit possible.

Expansion module EM-LON for retrofit

EM – LON

Description

Interface for one EASYLAB controller

- Local data interface for a fume cupboard controller, supply air controller, extract air controller, or adapter module TAM

Data points for a single controller

- Volume flow actual and setpoint values
- Damper blade position
- Operating mode
- Alarm/status messages
- Total supply air and total extract air actual values (room)
- Evaluated damper blade positions for all controllers in a room
- Number of controllers within the EASYLAB system
- Integration of volume flows
- Status of the digital inputs and outputs

Additional data points for a fume cupboard controller

- Operating mode default setting for the fume cupboard controller equipped with the expansion module
- Selection of priority for operating mode default setting
- Face velocity actual value and setpoint value (only for fume cupboard controllers with face velocity transducer, equipment function FH-VS)

2

LonWorks interface on a single controller, e.g. fume cupboard controller

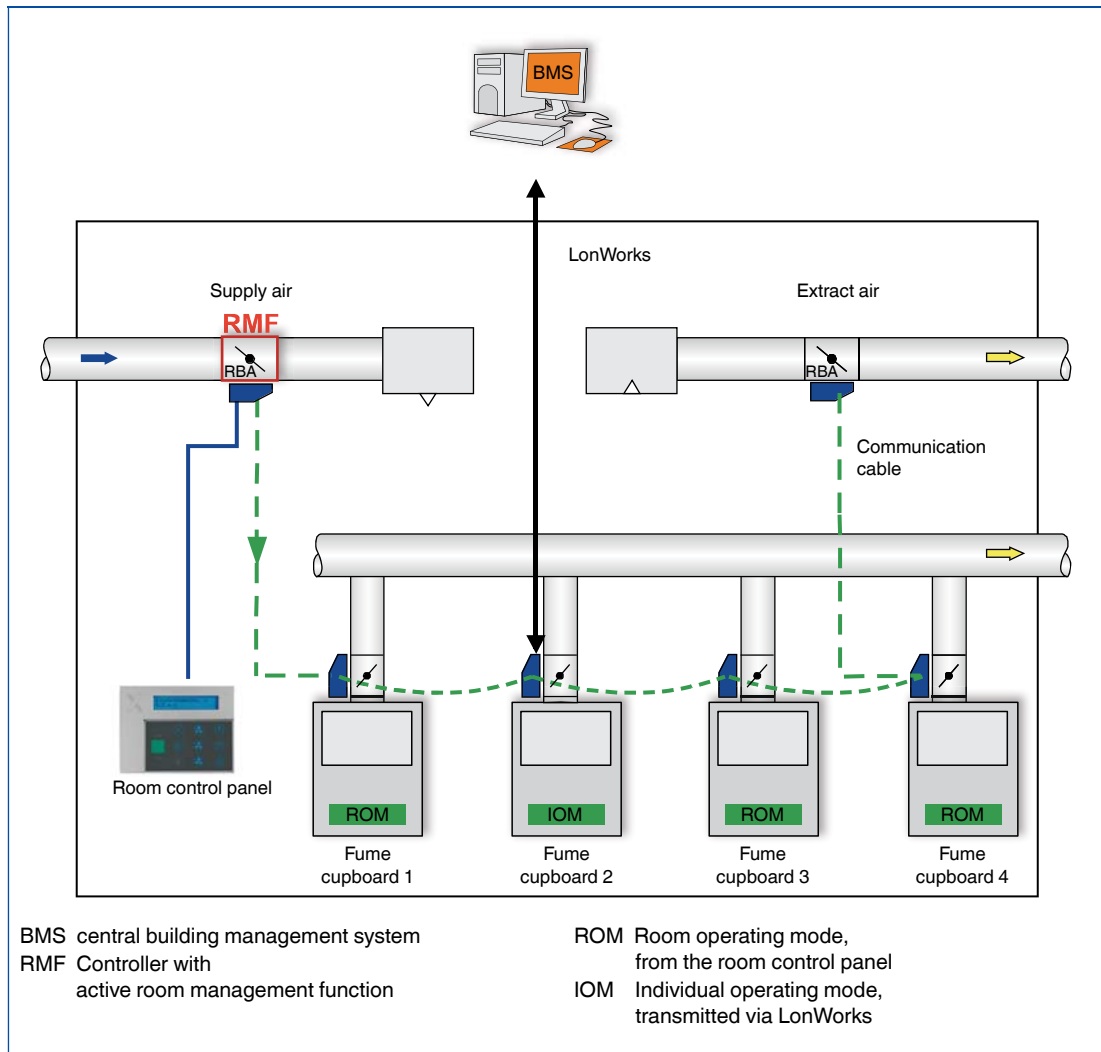

Description

Interface for one EASYLAB room

- Local data interface for a TCU3 room controller (supply air or extract air) or TAM adapter module with active room management function
 - Room management function reduces the required number of network data points and hence the commissioning costs
 - Transmission of local data for the single controller and for the room
- Data points for the room controller
- Operating mode default setting for the room: Just one data point is required to set the default operating mode for all controllers in a room
 - Selection of priority for operating mode default setting (central BMS or room)
 - Room operating mode
 - Volume flow rate setpoint change (by the central BMS, for example) for an external temperature or differential pressure control
- Setpoint value switching for differential pressure control: Switching between two differential pressure setpoint values
 - Total supply air and total extract air actual values (room)
 - Evaluated damper blade positions for all controllers in a room
 - Room differential pressure actual and setpoint values
 - Room pressure alarm
 - Number of controllers within the EASYLAB system
 - Integration of volume flows
 - Status of the digital inputs and outputs
 - Configurable consolidated alarm (operating statuses, hardware faults)
 - Control input signal for sun protection/blinds (to be provided by others)

LonWorks interface for an EASYLAB room, e.g. on a room controller with active room management function

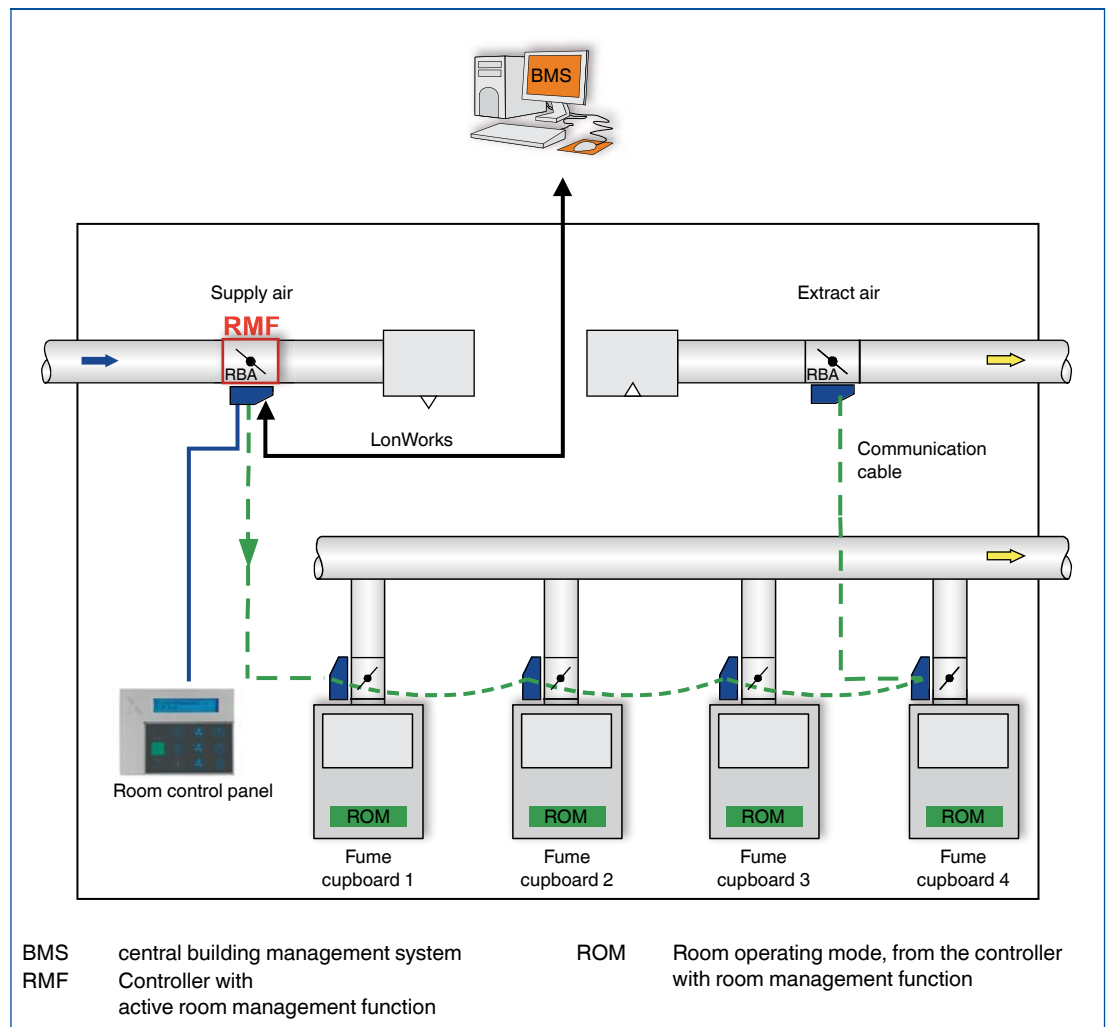

Description

Description of network variables (SNVT)

All variables and parameters are based on standard network variables (SNVT); this ensures integration of the expansion module EM-LON into a LonWorks network.

The equipment functions that support each variable are listed under the special information for that network variable.

Abbreviations

- FH: Fume cupboard controller
- RR: Room controller for supply air or extract air
- TAM: Adapter module
- RR-RMF: Room controller with active room management function
- TAM-RMF: Adapter module with active room management function

Operating mode default setting

- Input variables
 - nviManOverride (SNVT_hvac_overid),
 - nviOccCmd (SNVT_occupancy) and
 - nviMode (SNVT_state) are available for operating modes
- nviManOverride has the highest LON priority
- nviMode has the lowest LON priority.
- A configuration of the assignment is possible only for nviOccCmd by means of the parameter nciConfig_Occ (SCPTdirection).
- The valid binding of an input variable results in a valid operating mode default setting in LON for a single controller or for the room
- The invalid binding of an input variable does not result in an operating mode default setting in LON

Operating modes

Standard mode

Standard mode means normal operation in the daytime (in Germany: usually according to DIN 1946, part 7, 25 m³/h extract air per m² main useful floor area)

Reduced operation

Low mode in comparison to standard mode, e.g. as a night-time setback

Increased operation

High mode in comparison to standard mode, e.g. in an emergency

Shut-off mode

Shut-off of the volume flow controller, e.g. to save energy at night or to shut down the system

OPEN position

Open position of the volume flow controller

Virtual function block

nviManOP_Disable	nvoDampPos
nviManOverride	nvoDampPosMax_FH
nviMode	nvoDampPosMax_RE
nviOccCmd	nvoDampPosMax_RS
nviPressSetSel	nvoDampPosMax_TE
nviVolOffset_P	nvoDampPosMin_FH
nviVolOffset_T	nvoDampPosMin_RE
nviSunblinder	nvoDampPosMin_RS
nviVolflowExh	nvoDampPosMin_TE
nviVolflowSup	nvoLocalAlarm
	nvoManOverride
	nvoMode
	nvoOccCmd
	nvoManOverride_R
	nvoMode_R
	nvoOccCmd_R
	nvoPressAct
	nvoPressAlarm
	nvoPressSet
	nvoSummaryAlarm
	nvoSwitchPos
	nvoVelocityAct
	nvoVelocitySet
	nvoVolflowAct
	nvoVolflowSet
	nvoVolTotalExh
	nvoVolTotalSup
	nvoWireSensorPos
	nvoSystemDevices
	nvoStateDIO

Variables in black:

Valid for EM-LON firmware version 1.0 and higher

Variables in blue:

Valid for EM-LON firmware version 2.0 and higher

Overview of data points for LonWorks interface EM-LON firmware version 1.0

Name of variable	Data type	FH	RR	TAM	RR RMF	TAM RMF	Meaning
nviManOverride	SNVT_hvac_overid	x ¹			x	x	Operating mode default setting for controller or room
nviMode	SNVT_state	x ¹			x	x	Operating mode default setting for controller or room
nviOccCmd	SNVT_occupancy	x ¹			x	x	Operating mode default setting for controller or room
nviManOP_Disable	SNVT_switch	x ¹			x	x	Enabling/disabling manual control
nviVolOffset_T	SNVT_switch				x	x	Signalling of a volume flow rate setpoint change for temperature control
nviVolOffset_P	SNVT_switch				x	x	Signalling of a volume flow rate setpoint change for differential pressure control
nviPressSetSel	SNVT_switch				x	x	Switching between differential pressure setpoint values 1 and 2
nvoManOverride	SNVT_hvac_overid	x	x		x		Current operating mode of a single controller
nvoManOverride_R	SNVT_hvac_overid				x	x	Current operating mode for the room
nvoMode	SNVT_state	x	x		x		Current operating mode of a single controller
nvoMode_R	SNVT_state				x	x	Current operating mode for the room
nvoOccCmd	SNVT_occupancy	x	x		x		Current operating mode of a single controller
nvoOccCmd_R	SNVT_occupancy				x	x	Current operating mode for the room
nvoVolflowSet	SNVT_flow	x	x		x		Volume flow rate setpoint value for the controller
nvoVolflowAct	SNVT_flow	x	x		x		Volume flow rate actual value for the controller
nvoVolTotalExh	SNVT_flow	x	x	x	x	x	Total extract air of room
nvoVolTotalSup	SNVT_flow	x	x	x	x	x	Total supply air for the room
nvoPressSet	SNVT_press_p				x	x	Differential pressure setpoint value for the room
nvoPressAct	SNVT_press_p				x	x	Differential pressure actual value for the room
nvoLocalAlarm	SNVT_switch	x	x	x	x	x	Single controller alarm
nvoSummaryAlarm	SNVT_switch				x	x	Consolidated alarm for the room
nvoPressAlarm	SNVT_switch				x	x	Differential pressure alarm
nvoVelocitySet	SNVT_speed_mil	x					Face velocity actual value
nvoVelocityAct	SNVT_Count	x					Face velocity setpoint value
nvoSwitchPos	SNVT_switch	x					Sash position (stage 1,2,3)
nvoWireSensorPos	SNVT_switch	x					Sash position (sash opening %)
nvoDampPos	SNVT_switch	x	x		x		Damper blade position of single controller
nvoDampPosMax_FH	SNVT_switch	x	x	x	x	x	Evaluated damper blade position of fume cupboards – max
nvoDampPosMin_FH	SNVT_switch	x	x	x	x	x	Evaluated damper blade position of fume cupboards – min
nvoDampPosMax_RE	SNVT_switch	x	x	x	x	x	Evaluated damper blade position, extract air – max
nvoDampPosMin_RE	SNVT_switch	x	x	x	x	x	Evaluated damper blade position, extract air – min
nvoDampPosMax_TE	SNVT_switch	x	x	x	x	x	Evaluated damper blade position, total extract air – max
nvoDampPosMin_TE	SNVT_switch	x	x	x	x	x	Evaluated damper blade position, total extract air – min
nvoDampPosMax_RS	SNVT_switch	x	x	x	x	x	Evaluated damper blade position, supply air – max
nvoDampPosMin_RS	SNVT_switch	x	x	x	x	x	Evaluated damper blade position, supply air – min

FH: Fume cupboard controller

RR: Room controller for supply air or extract air

TAM: Adapter module

RR RMF: Room controller with active room management function

TAM RMF: Adapter module with active room management function

¹ only for individually selected operating mode (stand-alone operation)

Overview of additional data points for LonWorks interface EM-LON firmware version 2.0 and TCU firmware version 3.0

Name of variable	Data type	FH	RR	TAM	RR RMF	TAM RMF	Meaning
nviSunblinder	SNVT_switch				x	x	Control input signal for sun protection/blinds
nviVolflowExh	SNVT_flow	x	x	x	x	x	Connection of an extract air flow
nviVolflowSuph	SNVT_flow	x	x	x	x	x	Connection of a supply air flow
nvoSystemDevices	SNVT_count	x	x	x	x	x	Number of EASYLAB devices
nvoStateDIO	SNVT_state	x	x	x	x	x	State of the digital inputs and outputs (TCU3)

Configuration parameter

nciConfig_Occ

Type: SCPTdirection
Equipment functions: FH, RR with RMF, TAM with RMF

Function

- Assignment of SNVT_occupancy functional values to controller or room operating modes
- SNVT_occupancy used for operating mode default setting for a controller or a room
- nviOccCmd and nvoOccCmd are of type

SNVT_occupancy

nciMaxSendTime

Type: SCPTmaxSndT
Equipment functions: FH, RR, TAM, RR with RMF, TAM with RMF

Function

- Minimum updating interval for the LON output variables when the value of the variables remains unchanged.

FH: Fume cupboard controller

RR: Room controller for supply air or extract air

TAM: Adapter module

RR with RMF: Room controller with active room management function

TAM with RMF: Adapter module with active room management function

OC_OCCUPIED

Function	Bit			
	0	1	2	3
Standard mode	0	0	0	0
Reduced operation	0	0	0	1
Increased operation	0	0	1	0
Shut-off mode	0	1	0	0
OPEN position	1	0	0	0

OC_UNOCCUPIED

Function	Bit			
	4	5	6	7
Standard mode	0	0	0	0
Reduced operation	0	0	0	1
Increased operation	0	0	1	0
Shut-off mode	0	1	0	0
OPEN position	1	0	0	0

OC_BYPASS

Function	Bit			
	8	9	10	11
Standard mode	0	0	0	0
Reduced operation	0	0	0	1
Increased operation	0	0	1	0
Shut-off mode	0	1	0	0
OPEN position	1	0	0	0

OC_STANDBY

Function	Bit			
	12	13	14	15
Standard mode	0	0	0	0
Reduced operation	0	0	0	1
Increased operation	0	0	1	0
Shut-off mode	0	1	0	0
OPEN position	1	0	0	0

Input variables

nviManOverride

Type: SNVT_hvac_overid
Equipment functions: FH, RR with RMF, TAM with RMF

Function

- SNVT_hvac_overid functional values for operating mode default setting
- FH: Operating mode default setting for a single fume cupboard controller, only with individual operating mode default setting (stand-alone operation)
- RMF: Operating mode default setting for the entire EASYLAB room

nviOccCmd

Type: SNVT_occupancy
Equipment functions: FH, RR with RMF, TAM with RMF

Function

- SNVT_occupancy functional value for operating mode default setting
- FH: Operating mode default setting for a single fume cupboard controller, only with individual operating mode default setting (stand-alone operation)
- RMF: Operating mode default setting for the entire EASYLAB room

The assignment of functional values to operating modes is stored in the nciConfig_Occ table in the controller and can be configured

nviMode

Type: SNVT_state
Equipment functions: FH, RR with RMF, TAM with RMF

Function

- SNVT_state functional value for operating mode default setting
- FH: Operating mode default setting for a single fume cupboard controller, only with individual operating mode default setting (stand-alone operation)
- RMF: Operating mode default setting for the entire EASYLAB room

nviManOp_Disable

Type: SNVT_switch
Equipment functions: FH, RR with RMF, TAM with RMF

Function

- Upon enabling manual control the corresponding symbol appears on the fume cupboard or room control panels
- For further information on manual control please refer to the EASYLAB design manual.
- The variable includes the 'value' and 'state' fields but only the 'state' field is used.

Default values for nviManOverride

State	Description
HVO_Position	Standard mode
HVO_Close	Shut-off mode
HVO_Open	OPEN position
HVO_Minimum	Reduced operation
HVO_Maximum	Increased operation
HVO_Nul	No default

Assignment of functional values to operating modes – basic configuration

Value	Identifier	Operating mode
0	OC_OCCUPIED	Standard mode
1	OC_UNOCCUPIED	Reduced operation
2	OC_BYPASS	Increased operation
3	OC_BYPASS	Shut-off mode
0xFF	OC_NUL	No default

Default values for nviMode

Bit	Function	0	1
4/11	OPEN position	inactive	active
3/12	Shut-off mode	inactive	active
2/13	Increased operation	inactive	active
1/14	Reduced operation	inactive	active
0/15	Standard mode	inactive	active

Default settings for nviManOp_Disable

Value	State	Function
-	0	- Manual control has been enabled on the control panel - Operating mode defaults set on DI override LON
-	1	- Manual control has been disabled on the control panel - Operating mode default settings from LON have the highest priority

nviVolOffset_T

Type: SNVT_switch
Equipment functions: RR with RMF, TAM with RMF

Function

- Signalling of an external volume flow rate setpoint change, e.g. for adjusting the room air change rate or for external temperature control
- The change signal is transferred as a percentage value of a volume flow rate change range that has been configured in the controller
- The variable includes the 'value' and 'state' fields but only the 'value' field is used
- Depending on the room configuration, several controllers will assume the setpoint change function

nviVolOffset_P

Type: SNVT_switch
Equipment functions: RR with RMF, TAM with RMF

Function

- Signalling of a flow rate setpoint change for external differential pressure control
- The change signal is transferred as a percentage value of a volume flow rate change range that has been configured in the controller
- The variable includes the 'value' and 'state' fields but only the 'value' field is used

nviPressSetSel

Type: SNVT_switch
Equipment functions: RR with RMF, TAM with RMF

Function

- If room pressure control of the EASYLAB system is active, this is the input for switching between two differential pressure setpoint values that are stored in the room management function
- The variable includes the 'value' and 'state' fields

nviSunblinder

Type: SNVT_switch
Equipment functions: RR with RMF, TAM with RMF (firmware version 2.0 and higher)

Function

- Control input signal for sun protection/blinds, connected to the controller or adapter module
- Switching outputs DO5 and DO6 will be used
- This LonWorks default overrides any other defaults from the local room control panel

Default settings for nviVolOffset_T

Value	State	Function
Percentage value	–	External volume flow rate setpoint change for temperature: 0.0 – 100.0 %

Default settings for nviVolOffset_P

Value	State	Function
Percentage value	–	External volume flow rate setpoint change for differential pressure: 0.0 – 100.0 %

Default settings for nviPressSetSel

Value	State	Function
0	0	Differential pressure setpoint 1
100	1	Differential pressure setpoint 2

Default settings for nviSunblinder

Value	State	Description
0	0	Close blinds (activate switching output DO6)
100	1	Open blinds (activate switching output DO5)
0	-1	No default

nviVolflowExh

Type: SNVT_switch
Equipment functions: FH, RR, TAM, RR with RMF, TAM with RMF (firmware version 2.0 and higher)

Function

- Integration of an extract air flow into the room balance of the EASYLAB system
- This default volume flow is considered for all volume flow calculations (balance and setpoint values)

nviVolflowSup

Type: SNVT_flow, Einheit l/s
Equipment functions: FH, RR, TAM, RR with RMF, TAM with RMF (firmware version 2.0 and higher)

Function

- Integration of a supply air flow into the room balance of the EASYLAB system
- This default volume flow is considered for all volume flow calculations (balance and setpoint values)

Output variables

FH: Fume cupboard controller

RR: Room controller for supply air or extract air

TAM: Adapter module

RR with RMF: Room controller with active room management function

TAM with RMF: Adapter module with active room management function

nvoManOverride

Type: SNVT_hvac_overid
Equipment functions: FH, RR, RR with RMF

Function

- Output of the operating mode for the volume flow controller

nvoManOverride functional values

State	Description
HVO_Position	Standard mode
HVO_Close	Shut-off mode
HVO_Open	OPEN position
HVO_Minimum	Reduced operation
HVO_Maximum	Increased operation

nvoManOverride_R

Type: SNVT_hvac_overid
Equipment functions: RR with RMF, TAM with RMF

Function

- Output of the room operating mode

nvoManOverride_R functional values

State	Description
HVO_Position	Standard mode
HVO_Close	Shut-off mode
HVO_Open	OPEN position
HVO_Minimum	Reduced operation
HVO_Maximum	Increased operation

nvoMode

Type: SNVT_state

Equipment functions: FH, RR, RR with RMF

Function

- Output of the operating mode for the volume flow controller

nvoMode functional values

Bit	Function	0	1
11	OPEN position	inactive	active
12	Shut-off mode	inactive	active
13	Increased operation	inactive	active
14	Reduced operation	inactive	active
15	Standard mode	inactive	active

nvoMode_R

Type: SNVT_state

Equipment functions: RR with RMF, TAM with RMF

Function

- Output of the room operating mode

nvoMode_R functional values

Bit	Function	0	1
11	OPEN position	inactive	active
12	Shut-off mode	inactive	active
13	Increased operation	inactive	active
14	Reduced operation	inactive	active
15	Standard mode	inactive	active

nvoOccCmd

Type: SNVT_occupancy

Equipment functions: FH, RR

Function

- Output of the operating mode of the volume flow controller

nvoOccCmd functional values

Value	Identifier	Operating mode
0	OC_OCCUPIED	Standard mode
1	OC_UNOCCUPIED	Reduced operation
2	OC_BYPASS	Increased operation
3	OC_STANDBY	Shut-off mode

The assignment of functional values to operating modes is stored in a table in the controller and can be configured.

The table for the assignment of functional values of SNVT_occupancy in controller or room operating modes can be adapted by means of nciConfig_Occ.

nvoOccCmd_R

Type: SNVT_occupancy

Equipment functions: RR with RMF, TAM with RMF

Function

- Output of the room operating mode

The assignment of functional values to operating modes is stored in a table in the controller and can be configured.

The table for the assignment of SNVT_occupancy functional values to room operating modes can be adapted using the configuration parameter nciConfig_Occ.

nvoOccCmd_R functional values (basic configuration)

Value	Identifier	Operating mode
0	OC_OCCUPIED	Standard mode
1	OC_UNOCCUPIED	Reduced operation
2	OC_BYPASS	Increased operation
3	OC_STANDBY	Shut-off mode

nvoVolflowAct

Type: SNVT_flow, unit: l/s
Equipment functions: FH, RR, RR with RMF

Function

- Output of the volume flow rate actual value of the volume flow controller

nvoVolflowSet

Type: SNVT_flow, unit: l/s
Equipment functions: FH, RR, RR with RMF

Function

- Output of the volume flow rate setpoint value of the volume flow controller

nvoVolTotalExh

Type: SNVT_flow, unit: l/s
Equipment functions: FH, RR, TAM, RR with RMF, TAM with RMF

Function

- Output of the total extract air volume flow rate of an EASYLAB room
- This includes the extract air volume flow rates of all fume cupboards and extract air controllers as well as the additional extract air volume flow rates (constant and variable) from other controllers.

nvoVolTotalSup

Type: SNVT_flow, unit: l/s
Equipment functions: FH, RR, TAM, RR with RMF, TAM with RMF

Function

- Output of the total supply air flow rate of an EASYLAB room
- This includes the supply air volume flow rates of all supply air controllers as well as the additional supply air volume flow rates (constant and variable)

nvoVelocityAct

Type: SNVT_speed_mil, unit: m/s
Equipment function: FH

Function

- Output of the face velocity actual value if the fume cupboard controller is equipped with a face velocity transducer (FH-VS)

nvoVelocitySet

Type: SNVT_speed_mil, unit: m/s
Equipment function: FH

Function

- Output of the face velocity setpoint value if the fume cupboard controller is equipped with a face velocity transducer (FH-VS)

nvoWireSensor

Type: SNVT_switch
Equipment function: FH

Function

- Output of sash position of the fume cupboard as a percentage value between closed position (0 %) and open position (100 %) if the fume cupboard controller is equipped with a sash distance sensor (FH-DS, FH-DV)

nvoSwitchPos

Type: SNVT_Count
Equipment function: FH

Function

- Output of the current switching step of the fume cupboard as a numeric value if the fume cupboard controller is equipped with switch contacts for 2-point or 3-point control (FH-2P, FH-3P)

nvoSwitchPos functional values

Value	Description
1	Switching step 1
2	Switching step 2
3	Switching step 3
0	invalid

nvoPressAct

Type: SNVT_press_p, unit: Pa
Equipment functions: RR with RMF, TAM with RMF

Function

- Output of the differential pressure actual value within the EASYLAB system
- The actual value is recorded by a differential pressure transducer connected to the RR with RMF or to the TAM with RMF

nvoPressSet

Type: SNVT_press_p, unit: Pa
Equipment functions: RR with RMF, TAM with RMF

Function

- Output of the differential pressure setpoint value within the EASYLAB system

nvoDampPos

Type: SNVT_switch
Equipment functions: FH, RR, RR with RMF

Function

- Output of the damper blade position
- Damper blade position 0 – 100 %

nvoLocalAlarm

Type: SNVT_switch
Equipment functions: FH, RR, TAM, RR with RMF, TAM with RMF

Function

- Output of a local alarm for a fume cupboard controller, room controller or TAM
- Alarm conditions can be defined using the EasyConnect configuration software

nvoLocalAlarm functional values

Value	State	Description
0	0	Local alarm is inactive
100	1	Local alarm is active

nvoSummaryAlarm

Type: SNVT_switch

Equipment functions: RR with RMF, TAM with RMF

Function

- Output of a consolidated alarm
- An alarm signal is generated when a controller emits an alarm or fault message.
- Alarm conditions can be defined using the EasyConnect configuration software
- Standard configuration: volume flow rate alarm

nvoSummaryAlarm functional values

Value	State	Beschreibung
0	0	Consolidated alarm is inactive
100	1	Consolidated alarm is active

nvoPressAlarm

Type: SNVT_switch

Equipment functions: RR with RMF, TAM with RMF

Function

- Output of a room pressure alarm when room pressure control is active
- Alarm conditions can be defined using the EasyConnect configuration software

nvoPressAlarm functional values

Value	State	Beschreibung
0	0	Room pressure alarm inactive
100	1	Room pressure alarm active

nvoSystemDevices

Type: SNVT_count

Equipment functions: FH, RR, TAM, RR with RMF, TAM with RMF (firmware version 2.0 and higher)

Function

- Number of EASYLAB system components identified

nvoStateDIDO

Type: SNVT_state

Equipment functions: FH, RR, TAM, RR with RMF, TAM with RMF (firmware version 2.0 and higher)

Function

- Bit string indicating the states of the switching inputs and outputs of the controller or adapter module

Bit list

us16_varState_IO	LonWorks-Bit
Switching state DO6	2
Switching state DO5	3
Switching state DO4	4
Switching state DO3	5
Switching state DO2	6
Switching state DO1	7
Switching state DI6	10
Switching state DI5	11
Switching state DI4	12
Switching state DI3	13
Switching state DI2	14
Switching state DI1	15

Additional information for nvoDampMin_** and nvoDampMax_** functional values

nvoDampPosMin_** (State)

- 0 All damper blades in standard operating mode. Intervention is possible.
- 1 All damper blades in shut-off mode (special operating mode, value = 0 %). Intervention is not possible.
- 1 At least one damper blade in shut-off mode (special operating mode).

nvoDampPosMax_** (State)

- 0 All damper blades in standard operating mode. Intervention is possible.
- 1 All damper blades in OPEN mode (special operating mode, value = 100 %).
- 1 At least one damper blade in OPEN mode (special operating mode).

nvoDampPosMax_FH

Type: SNVT_switch
Equipment functions: FH, RR, TAM, RR with RMF, TAM with RMF

Function

- Output of the damper blade position of the fume cupboard controller with the widest open damper blade
- For the evaluation of the damper blade positions in separate extract air systems (2 fans), i.e. fume cupboard extract air and room extract air

nvoDampPosMin_FH

Type: SNVT_switch
Equipment functions: FH, RR, TAM, RR with RMF, TAM with RMF

Function

- Output of the damper blade position of the fume cupboard controller with the least wide open damper blade
- For the evaluation of the damper blade positions in separate extract air systems (2 fans), i.e. fume cupboard extract air and room extract air

nvoDampPosMax_RE

Type: SNVT_switch
Equipment functions: FH, RR, TAM, RR with RMF, TAM with RMF

Function

- Output of the damper blade position of the room extract air controller with the widest open damper blade
- For the evaluation of the damper blade positions in separate extract air systems (2 fans), i.e. fume cupboard extract air and room extract air

nvoDampPosMin_RE

Type: SNVT_switch
Equipment functions: FH, RR, TAM, RR with RMF, TAM with RMF

Function

- Output of the damper blade position of the room extract air controller with the least wide open damper blade
- For the evaluation of the damper blade positions in separate extract air systems (2 fans), i.e. fume cupboard extract air and room extract air

nvoDampPosMax_FH functional values

Value	State
Damper blade position	Additional information

nvoDampPosMin_FH functional values

Value	State
Damper blade position	Additional information

nvoDampPosMax_RE functional values

Value	State
Damper blade position	Additional information

Funktionswerte von nvoDampPosMin_RE

Value	State
Damper blade position	Additional information

nvoDampPosMax_TE

Type: SNVT_switch
Equipment functions: FH, RR, TAM, RR with RMF, TAM with RMF

Function

- Output of the damper blade position of the fume cupboard or room extract air controller with the widest open damper blade
- For the evaluation of the damper blade positions in the extract air system (1 fan) for fume cupboard and room extract air

nvoDampPosMin_TE

Type: SNVT_switch
Equipment functions: FH, RR, TAM, RR with RMF, TAM with RMF

Function

- Output of the damper blade position of the fume cupboard or room extract air controller with the least wide open damper blade
- For the evaluation of the damper blade positions in the extract air system (1 fan) for fume cupboard and room extract air

nvoDampPosMax_RS

Type: SNVT_switch
Equipment functions: FH, RR, TAM, RR with RMF, TAM with RMF

Function

- Output of the damper blade position of the room supply air controller with the widest open damper blade

nvoDampPosMin_RS

Type: SNVT_switch
Equipment functions: FH, RR, TAM, RR with RMF, TAM with RMF

Function

- Output of the damper blade position of the room supply air controller with the least wide open damper blade

nvoDampPosMax_TE functional values

Value	State
Damper blade position	Additional information

nvoDampPosMin_TE functional values

Value	State
Damper blade position	Additional information

nvoDampPosMax_RS functional values

Value	State
Damper blade position	Additional information

nvoDampPosMin_RS functional values

Value	State
Damper blade position	Additional information

Standard text

Expansion module to supplement an EASYLAB base component (controller TCU3 or adapter module TAM) with a LonWorks interface to link rooms or individual volume flow controllers to the central BMS.

The expansion module includes a LonWorks transceiver FTT-10A (free topology, twisted pair), a service pin push button for LonWorks integration, and indicator lights for 'sending data' and 'receiving data'.

Special features

- LonWorks free topology network with an arbitrary number of branches (star, line, and arbitrary combinations)
- Communication only using standard network variables (SNVT)
- Data interface for an EASYLAB controller or for an EASYLAB room with different functional profiles
- System integration (binding) into the LonWorks network is required

Technical data

- Communication: LonWorks-Transceiver FTT-10A, free topology, twisted pair
- Connection to LonWorks using the double-stack terminals

Data points for a single controller

- Volume flow actual and setpoint values
 - Damper blade position
 - Operating mode
 - Alarm/status messages
 - Total supply air and total extract air actual values (room)
 - Evaluated damper blade positions for all controllers in a room
 - Number of controllers within the EASYLAB system
 - Integration of volume flows
 - Status of the digital inputs and outputs
- Additional data points for a fume cupboard controller
- Operating mode default setting for the fume cupboard controller equipped with the expansion module
 - Selection of priority for operating mode default setting
 - Face velocity actual value and setpoint value (only for fume cupboard controllers with face velocity transducer, equipment function FH-VS)

Data points for EASYLAB room

- Operating mode default setting for the room: Just one data point is required to set the default operating mode for all controllers in a room
- Selection of priority for operating mode default setting (central BMS or room)
- Room operating mode
- Volume flow rate setpoint change (by the central BMS, for example) for an external temperature or differential pressure control
- Setpoint value switching for differential pressure control: Switching between two differential pressure setpoint values
- Total supply air and total extract air actual values (room)
- Evaluated damper blade positions for all controllers in a room
- Room differential pressure actual and setpoint values
- Room pressure alarm
- Number of controllers within the EASYLAB system
- Integration of volume flows
- Status of the digital inputs and outputs
- Configurable consolidated alarm (operating statuses, hardware faults)
- Control input signal for sun protection/blinds (to be provided by others)

Expansion modules

EM-BAC-MOD-01

2

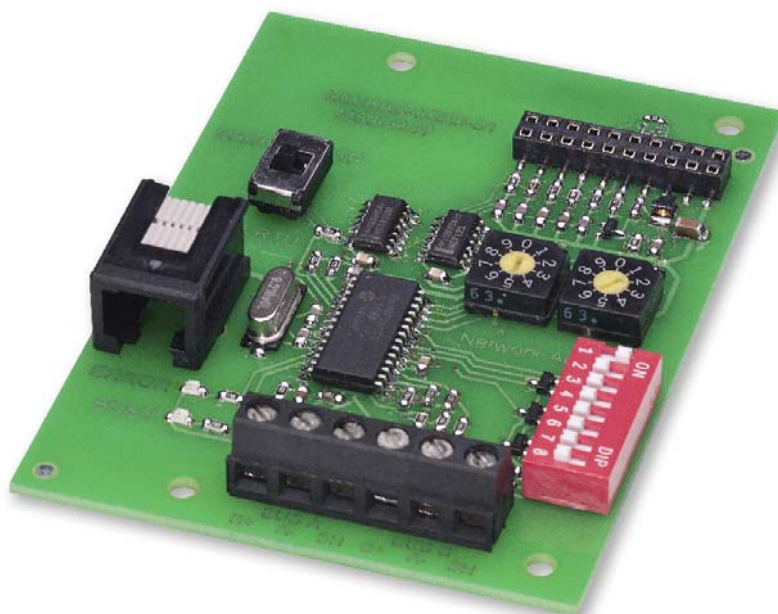

BACnet and Modbus interface for EASYLAB controllers and adapter modules

Expansion module for EASYLAB fume cupboard controllers, room controllers and adapter modules, for the integration of rooms or individual volume flow controllers with the central BMS

- Switching between BACnet MS/TP and Modbus RTU
- BACnet Standardised Device Profile (Annex L)
- Modbus interface with individual data registers
- Native BACnet interface by integrating the expansion module with EASYLAB components
- Easy retrofitting
- Double-stack terminals for the EIA-485 bus
- Equipment address and data transfer parameters can be defined

Interface to central BMS

- When used on a controller with active room management function (RMF) the module provides also data points for the entire room, e.g. for total volume flows or consolidated alarms
- When used on a single controller: data points for volume flow rate, alarm, damper blade position, or others
- Centralised operating mode default setting, e.g. night-time operation

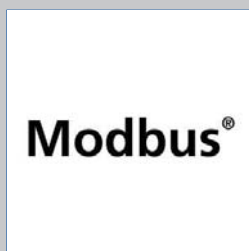

Modbus interface



BACnet-MS/TP interface

Type		Page
EM-BAC-MOD-01	General information	2.3 – 20
	Interface information – single controller	2.3 – 23
	Interface information – EASYLAB room	2.3 – 24
	Interface information – BACnet	2.3 – 25
	Interface information – Modbus	2.3 – 28
	Details	2.3 – 30
	Specification text	2.3 – 37
	Basic information and nomenclature	2.7 – 1

Description



Expansion module
BAC-MOD-01

Application

- Expansion module Type EM-BAC-MOD-01 for the EASYLAB system
- BACnet-MS/TP or Modbus RTU interface to the central BMS
- Data points for individual controllers or for the room
- Room interface: Default setting of room operating modes within the EASYLAB system, increase or reduction of the air change rate, readout of the actual room operating values or evaluated damper blade positions, consolidated alarms
- Controller interface: Operating mode default setting for a single fume cupboard controller, readout of individual operating values such as volume flow rates for single controllers, or individual alarms
- Can be used with fume cupboard, supply air, extract air or differential pressure controller EASYLAB TCU3 and with adapter module TAM
- For use in laboratories, clean rooms in the pharmaceutical and semiconductor industries, operation theatres, intensive care units, and offices with very demanding control requirements
- Factory mounted or for retrofitting into the EASYLAB base component casing

Special features

- Ready for installation, can be easily connected to the main PCB
- Interface for EIA-485 networks BACnet MS/TP and Modbus RTU
- BACnet Protocol Revision 12.0
- Only standard BACnet objects or Modbus registers are used for communication
- Data interface for an EASYLAB controller or for an EASYLAB room with different functional profiles
- Hardware switch to enter network addresses and communication parameters (no communication software required)

Parts and characteristics

- Microprocessor with setup programme stored in nonvolatile memory
- EIA-485 communications interface
- Slide switch to switch between BACnet and Modbus communication protocols
- Two address switches, X and Y, to set equipment addresses 1-99
- 8-way DIP switch to adjust the communication parameter
- Double-stack terminals for the EIA-485 network (simple wiring)
- Two indicator lights indicate communication and errors, respectively
- Connection to update the firmware
- EIA-485 terminal resistor that can be activated

Construction features

- PCB dimensions and fixing points correspond to the EASYLAB main PCB and the casing
- Fixing with screws
- Pin header to connect the module to the main PCB of the TCU3 or TAM

Installation and commissioning

Installation

- As attachment for the EASYLAB base component: factory mounted
- For retrofitting: Mount the expansion module into the base casing
- Make connection to the BACnet/Modbus EIA-485 network

Commissioning

- The EASYLAB controller identifies the expansion module automatically
- Select BACnet or Modbus protocol using slide switch
- Set network address and communication parameters using the coding switches
- If necessary, activate terminal resistor of the network segment
- Integrate data interface with the central BMS (system integration)

Technical data

Supply voltage	5 V DC from controller or adapter module
Communications interface	EIA-485 standard
Protocol	BACnet MS/TP standard rev. 12 or Modbus RTU
Data transmission speeds	BACnet: 9600, 19200, 38400, 76800 baud, Modbus: 9600, 19200, 38400, 57600 baud
Parity checks for data transmission security	None, odd, even
Configurable network addresses	01 ... 9901 ... 99
Operating temperature	0 – 50 °C
IEC protection class	III (protective extra-low voltage)
Protection level	IP 20
EC conformity	EMC according to 2004/108/EG
Dimensions (B x H x T)	78 x 65 x 100 mm

Function

Functional description

The expansion module EM-BAC-MOD-01 is used to integrate EASYLAB controllers Type TCU3 or EASYLAB adapter modules Type TAM into a BACnet (MS/TP) network and in this way connect them to the central BMS.

The BACnet or Modbus interface supports the EASYLAB room operating mode concept. It is possible to set operating mode defaults in order to control different volume flow rates for daytime and night-time operation; it is also possible to increase or reduce the air change rate (volume flow rate setpoint change), e.g. to influence the room temperature.

Using the BACnet or Modbus interface, an individual alarm management system can be set up by consolidating configurable EASYLAB alarms. The interface also enables the transfer of actual operating values such as volume flow rates and damper blade position for a controller or for all controllers in a room.

EM-BAC-MOD-01

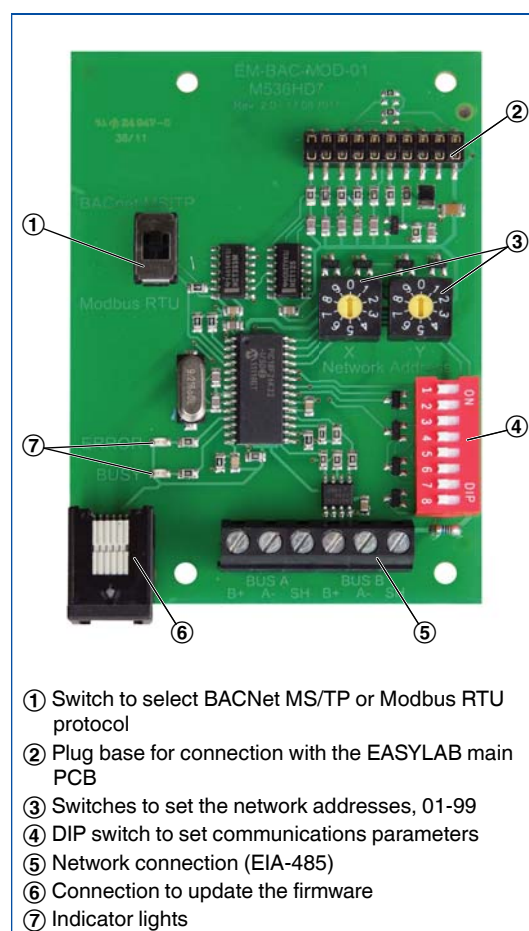

- ① Switch to select BACNet MS/TP or Modbus RTU protocol
- ② Plug base for connection with the EASYLAB main PCB
- ③ Switches to set the network addresses, 01-99
- ④ DIP switch to set communications parameters
- ⑤ Network connection (EIA-485)
- ⑥ Connection to update the firmware
- ⑦ Indicator lights

Order code

Any attachments must be defined with the order code of the VAV terminal unit.

**Order code detail for control component
ELAB (TCU3) or TAM**

ELAB / ...B... / ...
ELAB / ...M... / ...

2

Retrofit possible.

Expansion module EM-BAC-MOD-01 for retrofit

EM – BAC – MOD – 01

Description

Interface for one EASYPAC controller

- Local data interface for a fume cupboard controller, supply air controller, extract air controller, or adapter module TAM

Data points for a single controller

- Volume flow actual and setpoint values
- Damper blade position
- Operating mode
- Alarm/status messages
- Total supply air and total extract air actual values (room)
- Evaluated damper blade positions for all controllers in a room
- Number of controllers

- Integration of volume flows
- Status of the digital inputs and outputs

Additional data points for a fume cupboard controller

- Operating mode default setting for the fume cupboard controller equipped with the expansion module
- Selection of priority for operating mode default setting
- Face velocity actual value and setpoint value (only for fume cupboard controllers with face velocity transducer, equipment function FH-VS)

BACnet or Modbus interface on a single controller, e.g. fume cupboard controller

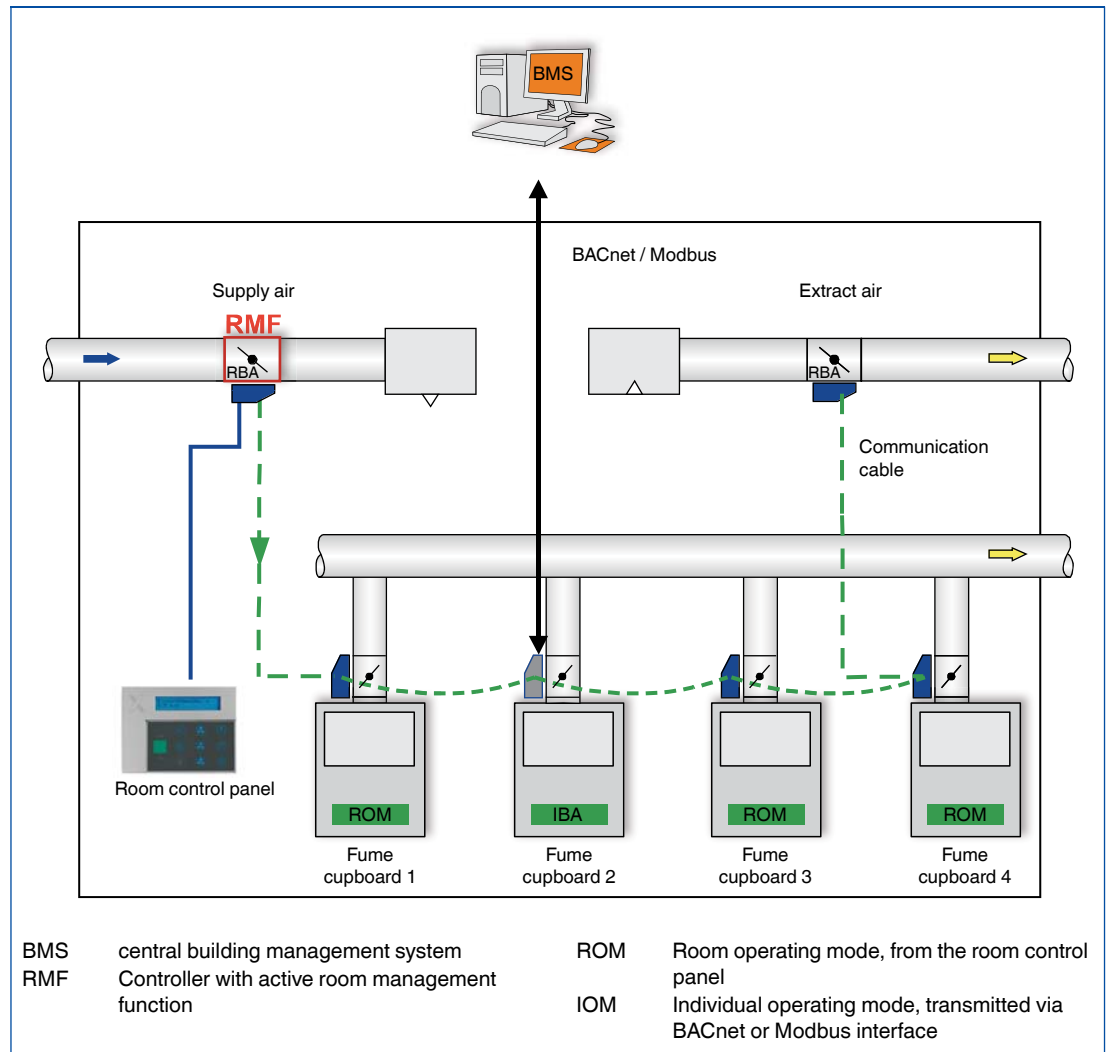

Description

Interface for one EASYLAB room

- Local data interface for a TCU3 room controller (supply air or extract air) or TAM adapter module with active room management function
 - Room management function reduces the required number of network data points and hence the commissioning costs
 - Transmission of local data for the single controller and for the room
- Data points for EASYLAB room controller
- Operating mode default setting for the room: Just one data point is required to set the default operating mode for all controllers in a room
 - Selection of priority for operating mode default setting (central BMS or room)
 - Room operating mode
 - Volume flow rate setpoint change (by the central BMS, for example) for an external temperature or differential pressure control
- Setpoint value switching for differential pressure control: Switching between two differential pressure setpoint values
 - Total supply air and total extract air actual values (room)
 - Evaluated damper blade positions for all controllers in a room
 - Room differential pressure actual and setpoint values
 - Room pressure alarm
 - Number of controllers within the EASYLAB system
 - Integration of volume flows
 - Status of the digital inputs and outputs
 - Configurable consolidated alarm (operating statuses, hardware faults)
 - Control input signal for sun protection/blinds (to be provided by others)

BACnet or Modbus interface for an EASYLAB room, e.g. on a room controller with active room management function

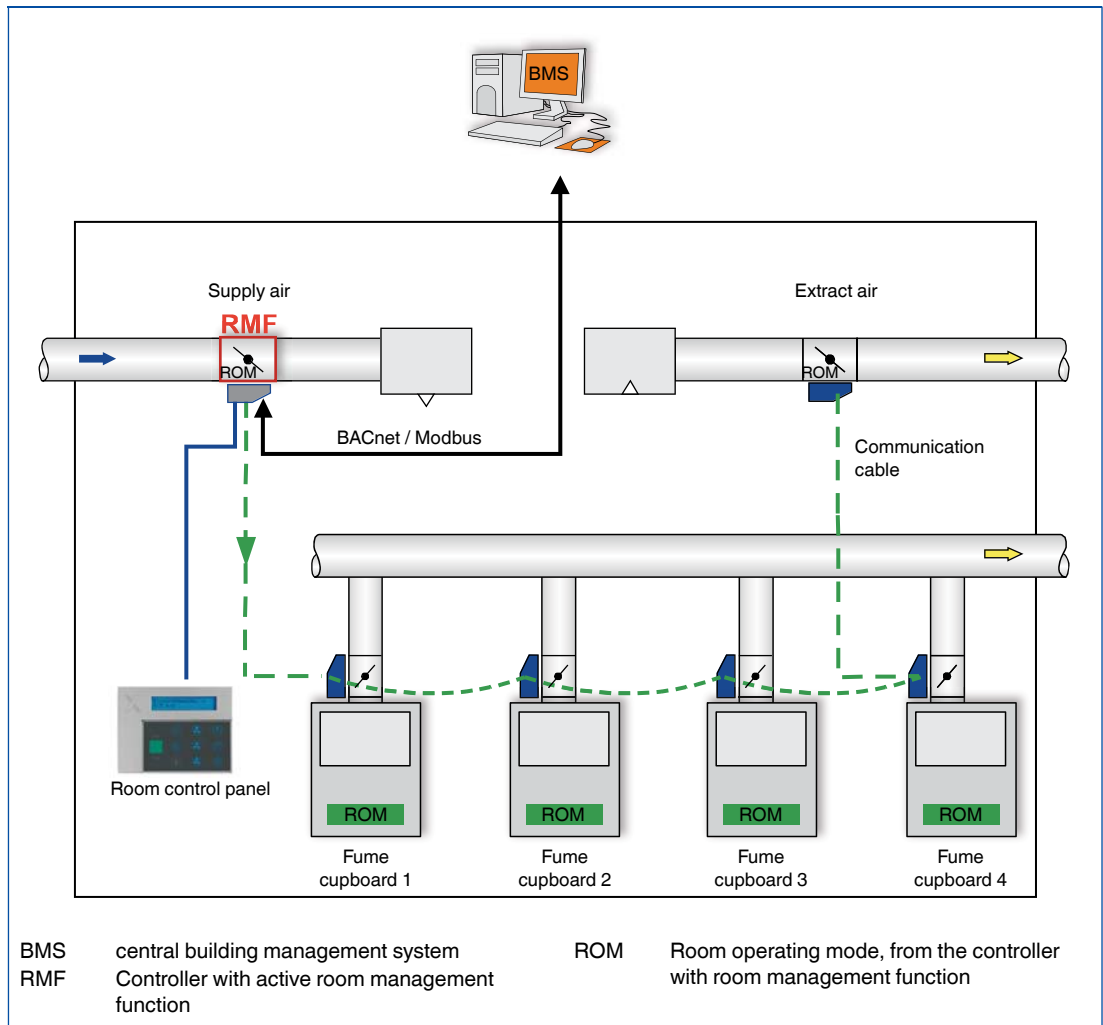

Description

Application

The expansion module EM-BAC-MOD-01 supports the following interface functions on an EASYLAB controller TCU3 or an adapter module TAM if the BACnet protocol has been selected:

- Native BACnet, i.e. the BACnet interface is implemented on the field module (EASYLAB volume flow controller)
- External hardware components such as physical gateways are not required

- BACnet interface documentation includes the following documents: Protocol Implementation Conformance Statement (PICS), BACnet Interoperability Building Blocks Supported (BIBBS), as well as a description of the device object and the supported objects
- For more information on each data point see the Details section

Interface functions

BACnet PICS (Protocol Implementation Conformance Statement) – Overview

Principal categories	Values
Date	2011-07-20
Vendor name	TROX GmbH
Vendor identifier	329
Product name	EM-BAC-MOD-01
Model no.	M536HD7
Application	2.0
Firmware Revision	2.0
BACnet Protocol Revision	12
Standardised Device Profile	BACnet Application Specific Controller (B-ASC)
Segmentation Capability	No
Data Link Layer Options	MS/TP master (Clause 9), Baudrates 9600, 19200, 38400, 76800
Device Address Binding	No
Network Security Options	Non-secure Device - is capable of operating without BACnet Network Security
Character Sets Supported	ISO 10646 (UTF-8)

Configuration switches

Hexadecimal Switches X, Y Network-Adress	Hexadecimal Switches X, Y Network-Adress			
DIP Switch 1	OFF	ON		
Controller	EASYLAB TCU3	Other		
DIP Switch 2	OFF	ON	OFF	ON
DIP Switch 3	OFF	OFF	ON	ON
Baud rate	9600	19200	38400	76800
Baud rate	-	-	-	-

BIBBS - BACnet Interoperability Building Blocks Supported

Data Sharing-ReadProperty-B	DS-RP-B
Data Sharing-WriteProperty-B	DS-WP-B
Data Sharing-COV-Unsolicited-B	DS-COVU-B
Device Management-Dynamic Device Binding-B	DM-DDB-B
Device Management-Dynamic Object Binding-B	DM-DOB-B
Device Management-Device Communication Control-B	DM-DCC-B
Device Management-ReinitialiseDevice-B	DM-RD-B

BACnet PICS

Access rights:

RD: Read

WR: Write

E: Save in EEPROM

DeviceObject

Property	Value	Access right
Object identifier	Device instance = 32900 + set network address	WR, RD; E
Object name	Default=EM-BACnet; project-specific description can be entered, 50 characters max.	WR, RD; E
Object type	Device (8)	RD
System_Status	OPERATIONAL (0)	RD
Vendor_Name	"TROX GmbH"	RD
Vendor_Identifier	329	RD
Model_Name	EM-BAC-MOD-01	RD
Firmware_Revision	"2.0" (EASYLAB)	RD
Application_Software_Version	"2.0" (EASYLAB)	RD
Protocol_Version	1	RD
Protocol_Revision	12	RD
Protocol Services Supported	Who-is, Who-has, Read-Property, Write-Property, Device-communication-control, Reinitialize-device	RD
Protocol_Object_Types_Supported	DEVICE, ANALOG_VALUE, BINARY_VALUE, MULTISTATE_VALUE	RD
Object_List	EASYLAB: device, analog-value 1...25, binary-value 1...18, multistate-value 1...8	RD
Max_ADPU_Length_Accepted	275	RD
Segmentation_Supported	NO_SEGMENTATION (3)	RD
APDU_Timeout	3000	RD
Number_Of_APDU_Retries	0	RD
Device_Address_Binding	-	RD
Database_Revision	0	RD
Description	Controller Type "EASYLAB"	RD
Max_Master	Default 127	WR, RD; E
Max_Info_Frames	Default 1	WR, RD; E

BACnet PICS

FH: Fume cupboard controller

RR: Room controller for supply air or extract air

TAM: Adapter module

RR with RMF: Room controller with active room management function

TAM with RMF: Adapter module with active room management function

Multistate Value Objects

Multistate Value Objects	Multistate Value Objects	Available with equipment function					Access
		FH	RR	TAM	RR RMF	TAM RMF	
1	COV-Mode	x	x	x	x	x	WR, RD
2	Mode	x ¹			x	x	WR, RD
3	ModeAct	x	x		x		RD
4	RoomModeAct				x	x	RD
5	SwitchPos	x					RD
6	Sunblind				x	x	WR, RD

¹ only for individually selected operating mode (stand-alone operation)

Access rights:

RD: Read

WR: Write

BACnet PICS

FH: Fume cupboard controller

RR: Room controller for supply air or extract air

TAM: Adapter module

RR with RMF: Room controller with active room management function

TAM with RMF: Adapter module with active room management function

Access rights:

RD: Read

WR: Write

Analogue Value Objects

Analogue Value Objects	Analogue Value Objects	Available with equipment function					Access	
		Instance	Designation	FH	RR	TAM		RR RMF
1	VolflowSet	x	x			x	x	RD
2	VolflowAct	x	x			x	x	RD
3	VolTotalExh	x	x	x		x	x	RD
4	VolTotalSup	x	x	x		x	x	RD
5	PressSet					x	x	RD
6	PressAct					x	x	RD
7	VelocitySet	x						RD
8	VelocityAct	x						RD
9	WireSensorPos	x						RD
10	DampPos	x	x			x		RD
11	DampPosMax_FH	x	x	x		x	x	RD
12	DampPosMin_FH	x	x	x		x	x	RD
13	DampPosMax_RE	x	x	x		x	x	RD
14	DampPosMin_RE	x	x	x		x	x	RD
15	DampPosMax_TE	x	x	x		x	x	RD
16	DampPosMin_TE	x	x	x		x	x	RD
17	DampPosMax_RS	x	x	x		x	x	RD
18	DampPosMin_RS	x	x	x		x	x	RD
19	VolOffset_T					x	x	WR, RD
20	VolOffset_P					x	x	WR, RD
21	SystemDevices	x	x	x		x	x	RD
22	VolflowExh	x	x	x		x	x	WR, RD
23	VolflowSup	x	x	x		x	x	WR, RD

BACnet PICS

FH: Fume cupboard controller

RR: Room controller for supply air or extract air

TAM: Adapter module

RR with RMF: Room controller with active room management function

TAM with RMF: Adapter module with active room management function

Access rights:

RD: Read

WR: Write

Binary Value Objects

Binary Value Objects	Binary Value Objects	Available with equipment function					Access	
		Instance	Designation	FH	RR	TAM		RR RMF
1	LocalAlarm (COVU)	x	x	x		x	x	RD
2	SummaryAlarm (COVU)					x	x	RD
3	PressAlarm (COVU)					x	x	RD
4	ManOp_Disable	x ¹				x	x	WR, RD
5	PressSetSel					x	x	WR, RD
6	DI1	x	x	x		x	x	RD
7	DI2	x	x	x		x	x	RD
8	DI3	x	x	x		x	x	RD
9	DI4	x	x	x		x	x	RD
10	DI5	x	x	x		x	x	RD
11	DI6	x	x	x		x	x	RD
12	DO1	x	x	x		x	x	RD
13	DO2	x	x	x		x	x	RD
14	DO3	x	x	x		x	x	RD
15	DO4	x	x	x		x	x	RD
16	DO5	x	x	x		x	x	RD
17	DO6	x	x	x		x	x	RD

¹ only for individually selected operating mode (stand-alone operation)

Description

Application

The expansion module EM-BAC-MOD-01 supports the following interface functions on an EASYLAB controller TCU3 or an adapter module TAM if the Modbus protocol has been selected:

- Modbus is an open serial master-slave communications protocol which has become a de facto standard for the industry
- The master (e.g. central BMS) can address a number of slaves (EASYLAB volume flow controllers) and use Modbus functions to request information from individual data points

- Data access is based on numbered data registers which the master has to define in order to request data using Modbus functions
- The slave responds by either returning the requested information or an exception code (error)
- Example: The Read Input Registers function (register no. 3) returns the volume flow rate actual value of the addressed controller
- General information for a Modbus device can be read out using the Read Device Identification function

Interface functions

Modbus functions

Function number	Designation	Meaning
1 (0x01)	Read Coils	Read states of 1 to 8 bits according to bit list
3 (0x03)	Read Holding Registers	Read several consecutive registers
4 (0x04)	Read Input Registers	Read several consecutive registers
5 (0x05)	Write Single Coil	Write state of a single bit
6 (0x06)	Write Single Register	Write single register
8 (0x08)	Diagnostics	Check Modbus communication
16 (0x10)	Write Multiple Registers	Write several consecutive registers
43 (0x2B)	Read Device Identification	Read identification data for the device
14 (0x0E)	Read Device Identification	Read identification data for the device

Exception Codes

Codes	Designation	Meaning
1	Illegal Function Code	Unknown function or subfunction code
2	Illegal Data Address	Invalid register address
3	Illegal Data Value	Inconsistent coding for number of registers/bytes, data value

Exception codes (error codes) are returned in case of invalid function or register access.

FH: Fume cupboard controller

RR: Room controller for supply air or extract air

TAM: Adapter module

RR with RMF: Room controller with active room management function

TAM with RMF: Adapter module with active room management function

Bit list for ReadCoil/WriteSingleCoil functions

Bit No.	Bit Designation	Available with equipment function					Access
		FH	RR	TAM	RR-RMF	TAM-RMF	
0	ManOp_Disable	x ¹			x	x	WR
1	PressSetSel				x	x	WR
2	Local Alarm	x	x		x		RD
3	SummaryAlarm				x	x	RD
4	PressAlarm				x	x	RD

Bits are read with function 1 (RD) or written with function 5 (WR).

¹ only for individually selected operating mode (stand-alone operation)

Access rights:

RD: Read

WR: Write

FH: Fume cupboard controller

RR: Room controller for supply air or extract air

TAM: Adapter module

RR with RMF: Room controller with active room management function

TAM with RMF: Adapter module with active room management function

Access rights:

RD: Read

WR: Write

Register list for Read*Registers and Write***Registers functions**

Register No.	Register Designation	Available with equipment function					Access
		FH	RR	TAM	RR-RMF	TAM-RMF	
0	Mode	x ¹			x	x	WR
1	ManOpDisable	x ¹			x	x	WR
2	ModeAct	x	x		x		RD
3	VolflowAct	x	x		x		RD
4	VolflowSet	x	x		x		RD
5	VelocityAct	x					RD
6	VelocitySet	x					RD
7	VolTotalExh	x	x	x	x	x	RD
8	VolTotalSup	x	x	x	x	x	RD
9	VolOffset_T				x	x	WR
10	VolOffset_P				x	x	WR
11	PressAct				x	x	RD
12	PressSet				x	x	RD
13	PressSetSel				x	x	WR
14	DampPos	x	x		x		RD
15	DampPosMax_FH - Value	x	x	x	x	x	RD
16	DampPosMax_FH - Status	x	x	x	x	x	RD
17	DampPosMin_FH - Value	x	x	x	x	x	RD
18	DampPosMin_FH - Status	x	x	x	x	x	RD
19	DampPosMax_RE - Value	x	x	x	x	x	RD
20	DampPosMax_RE - Status	x	x	x	x	x	RD
21	DampPosMin_RE - Value	x	x	x	x	x	RD
22	DampPosMin_RE - Status	x	x	x	x	x	RD
23	DampPosMax_TE - Value	x	x	x	x	x	RD
24	DampPosMax_TE - Status	x	x	x	x	x	RD
25	DampPosMin_TE - Value	x	x	x	x	x	RD
26	DampPosMin_TE - Status	x	x	x	x	x	RD
27	DampPosMax_RS - Value	x	x	x	x	x	RD
28	DampPosMax_RS - Status	x	x	x	x	x	RD
29	DampPosMin_RS - Value	x	x	x	x	x	RD
30	DampPosMin_RS - Status	x	x	x	x	x	RD
31	Local Alarm	x	x	x	x	x	RD
32	SummaryAlarm				x	x	RD
33	PressAlarm				x	x	RD
34	WireSensorPos	x					RD
35	SwitchPos	x					RD
36	RoomModeAct				x	x	RD
37	SystemDevices	x	x	x	x	x	RD
38	SetSunBlind				x	x	WR
39	DI_Status	x	x	x	x	x	RD
40	DO_Status	x	x	x	x	x	RD
41	IntegrateVolflowExh	x	x	x	x	x	WR
42	IntegrateVolflowSup	x	x	x	x	x	WR

¹ only for individually selected operating mode (stand-alone operation)

Description

Data points – detailed description

The following is a detailed description of the information that each data point provides; input variables and output variables are described separately:

- Name of data point
- Access as viewed from the central BMS
- WR – Defaults for the volume flow controller or room, from the central BMS
- RD – Data provided by the volume flow controller or room

- List of volume flow controller equipment functions for which the variable is available
- Physical unit
- Function and special functional values with their meaning
- Access to the data point using a BACnet object or Modbus register

Input variables

FH: Fume cupboard controller

RR: Room controller for supply air or extract air

TAM: Adapter module

RR with RMF: Room controller with active room management function

TAM with RMF: Adapter module with active room management function

Access rights:

RD: Read

WR: Write

Mode

BMS access: WR

Equipment functions: FH, RR with RMF, TAM with RMF

Function

- FH: Operating mode default setting for a single fume cupboard controller, only with individual operating mode default setting (stand-alone operation)
- RMF: Operating mode default setting for the entire EASYLAB room
- The valid binding of the input variable results in a valid operating mode default setting via BACnet or Modbus
- The invalid binding of an input variable or failure to set an operating mode default results in no operating mode default being set for the EASYLAB controller or room
- Which operating mode is then used depends on the default options available on the controller

Functional values

- 0 = No default: The central BMS does not default an operating mode for the controller or room. Instead, the operating mode is set locally, e.g. on the room control panel, on the fume cupboard control panel, or using switch contacts. If the operating mode is not set locally, the controller activates standard mode.
- 1 = Standard mode: Normal operation in the daytime (in Germany: usually according to DIN 1946, part 7, 25 m³/h extract air per m² main useful floor area)
- 2 = Reduced operation: Low mode in comparison to standard mode, e.g. as a night-time setback
- 3 = Increased operation: High mode in comparison to standard mode, e.g. in an emergency
- 4 = Shut-off: Shut-off of the volume flow controller, e.g. to save energy at night or to shut down the system
- 5 = OPEN position: Open position of the volume flow controller

Data point

- BACnet: Multistate Value Object - Instance 2
- Modbus: Register 0

ManOp_Disable

BMS access: WR

Equipment functions: FH, RR with RMF, TAM with RMF

Function

- Enabling/disabling manual control
- Upon enabling manual control the corresponding symbol appears on the control panels
- For further information on manual control please refer to the EASYLAB design manual.
- FH: Operating mode default setting for a fume cupboard controller, only with individual operating mode default setting (stand-alone operation)
- RMF: Operating mode default setting for the entire EASYLAB room

Functional values

- 0: Manual control has been enabled on the control panel; operating mode defaults set on DI override BACnet or Modbus defaults.
- 1: Manual control has been disabled on the control panel; operating mode default settings from BACnet or Modbus have the highest priority

Data point

- BACnet: Binary Value Object - Instance 4
- Modbus: Bit list – bit 0 or register 1

VolOffset_T

BMS access: WR

Equipment functions: RR with RMF, TAM with RMF

Unit: Percentage value in increments of 0.5 %

Function

- Signalling of an external volume flow rate setpoint change, e.g. for adjusting the room air change rate or for external temperature control
- The change signal is transferred as a percentage value of a volume flow rate change range that has been configured in the controller

Data point

- BACnet: Analog Value Object - Instance 19
- Modbus: Register 9

VolOffset_P

BMS access: WR

Equipment functions: RR with RMF, TAM with RMF

Unit: Percentage value in increments of 0.5 %

Function

- Signalling of a flow rate setpoint change for external differential pressure control
- The change signal is transferred as a percentage value of a volume flow rate change range that has been configured in the controller

Data point

- BACnet: Analog Value Object - Instance 20
- Modbus: Bit list - bit 1 or register 10

PressSetSel

BMS access: WR

Equipment functions: RR with RMF, TAM with RMF

Function

- If room pressure control of the EASYLAB system is active, this is the input for switching between two differential pressure setpoint values that are stored in the room management function

Functional values

- 0: Use differential pressure setpoint 1
- 1: Use differential pressure setpoint 2

Data point

- BACnet: Binary Value Object - Instance 5
- Modbus: Bit list – bit 1 or register 13

VolflowExh

BMS access: WR

Equipment functions: FH, RR, TAM, RR with RMF, TAM with RMF

Unit: l/s

Function

- Integration of an extract air flow into the room balance of the EASYLAB system
- This default volume flow is considered for all volume flow calculations (balance and setpoint values)

Data point

- BACnet: Analog Value Object - Instance 22
- Modbus: Register 41

VolflowSup

BMS access: WR

Equipment functions: FH, RR, TAM, RR with RMF, TAM with RMF

Unit: l/s

Function

- Integration of a supply air flow into the room balance of the EASYLAB system
- This default volume flow is considered for all volume flow calculations (balance and setpoint values)

Data point

- BACnet: Analog Value Object - Instance 23
- Modbus: Register 42

Sunblind

BMS access: WR

Equipment functions: RR with RMF, TAM with RMF

Function

- Control input signal for sun protection/blinds, connected to the controller or adapter module
- Switching outputs DO5 and DO6 will be used
- This BACnet or Modbus default overrides any other defaults from the local room control panel

Data point

- BACnet: Multistate Value Object - Instance 6
- 1 = No default
- 2 = Close blinds (activate switching output DO6)
- 3 = Open blinds (activate switching output DO5)

Modbus: Register 38

- 0 = Close blinds
- 1 = Open blinds
- 0xFF = No default

COV mode (only BACnet)

BMS access: WR

Equipment functions: FH, RR, TAM, RR with RMF, TAM with RMF

Function

- BACnet control function

Data point

- BACnet: Multistate Value Object - Instance 1

Output variables

FH: Fume cupboard controller

RR: Room controller for supply air or extract air

TAM: Adapter module

RR with RMF: Room controller with active room management function

TAM with RMF: Adapter module with active room management function

Access rights:

RD: Read

ModeAct

BMS access: RD

Equipment functions: FH, RR, RR with RMF

Function

- Output of the operating mode for the volume flow controller
- For more information on each operating mode see the description of the Mode input variable

Functional values

- 0 = No default
- 1 = Standard mode
- 2 = Reduced operation
- 3 = Increased operation
- 4 = Shut-off
- 5 = OPEN position

Data point

- BACnet: Multistate Value Object - Instance 3
- Modbus: Register 2

RoomModeAct

BMS access: RD

Equipment functions: RR with RMF, TAM with RMF

Function

- Output of the room operating mode
- For more information on each operating mode see the description of the Mode input variable

Functional values

- 0 = No default
- 1 = Standard mode
- 2 = Reduced operation
- 3 = Increased operation
- 4 = Shut-off
- 5 = OPEN position

Data point

- BACnet: Multistate Value Object - Instance 4
- Modbus: Register 36

VolflowSet

BMS access: RD

Equipment functions: FH, RR, RR with RMF

Unit: l/s

Function

- Output of the volume flow rate setpoint value of the volume flow controller

Data point

- BACnet: Analog Value Object - Instance 1
- Modbus: Register 4

VolflowAct

BMS access: RD

Equipment functions: FH, RR, RR with RMF

Unit: l/s

Function

- Output of the volume flow rate actual value of the volume flow controller

Data point

- BACnet: Analog Value Object - Instance 2
- Modbus: Register 3

VolTotalExh

BMS access: RD

Equipment functions: FH, RR, TAM, RR with RMF, TAM with RMF

Unit: l/s

Function

- Output of the total extract air volume flow rate of an EASYLAB room
- This includes the extract air volume flow rates of all fume cupboards and extract air controllers as well as the additional extract air volume flow rates (constant and variable) from other controllers.

Data point

- BACnet: Analog Value Object - Instance 3
- Modbus: Register 7

VolTotalSup

BMS access: RD

Equipment functions: FH, RR, TAM, RR with RMF, TAM with RMF

Unit: l/s

Function

- Output of the total supply air flow rate of an EASYLAB room
- This includes the supply air volume flow rates of all supply air controllers as well as the additional supply air volume flow rates (constant and variable)

Data point

- BACnet: Analog Value Object - Instance 4
- Modbus: Register 8

VelocitySet

BMS access: RD

Equipment function: FH

Unit: m/s

Function

- Output of the face velocity setpoint value if the fume cupboard controller is equipped with a face velocity transducer (FH-VS)

Data point

- BACnet: Analog Value Object - Instance 7
- Modbus: Register 6

VelocityAct

BMS access: RD
Equipment function: FH
Unit: m/s

Function

- Output of the face velocity actual value if the fume cupboard controller is equipped with a face velocity transducer (FH-VS)

Data point

- BACnet: Analog Value Object - Instance 8
- Modbus: Register 5

WireSensorPos

BMS access: RD
Equipment function: FH
Unit: Percentage value in increments of 0.5 %

Function

- Output of sash position of the fume cupboard as a percentage value between closed position (0 %) and open position (100 %) if the fume cupboard controller is equipped with a sash distance sensor (FH-DS, FH-DV)

Data point

- BACnet: Analog Value Object - Instance 9
- Modbus: Register 34

SwitchPos

BMS access: RD
Equipment function: FH

Function

- Output of the current switching step of the fume cupboard as a numeric value if the fume cupboard controller is equipped with switch contacts for 2-point or 3-point control (FH-2P, FH-3P)

Data point

- BACnet: Multistate Value Object - Instance 5 (1 = invalid state; 2 = switching step 1; 3 = switching step 2; 4 = switching step 3)
- Modbus: Register 35 (1 = switching step 1; 2 = switching step 2; 3 = switching step 3)

PressSet

BMS access: RD
Equipment functions: RR with RMF, TAM with RMF
Unit: Pa

Function

- Output of the differential pressure setpoint value within the EASYLAB system

Data point

- BACnet: Analog Value Object - Instance 5
- Modbus: Register 12

PressAct

BMS access: RD
Equipment functions: RR with RMF, TAM with RMF
Unit: Pa

Function

- Output of the differential pressure actual value within the EASYLAB system
- The actual value is recorded by a differential pressure transducer connected to the RR with RMF or to the TAM with RMF

Data point

- BACnet: Analog Value Object - Instance 6
- Modbus: Register 11

LocalAlarm

BMS access: RD
Equipment functions: FH, RR, TAM, RR with RMF, TAM with RMF

Function

- Output of a local alarm for a fume cupboard controller, room controller or TAM
- Alarm conditions can be defined using the EasyConnect configuration software

Functional values

- 0 = No local alarm
- 1 = Local alarm

Data point

- BACnet: Binary Value Object - Instance 1 – (BIBBS-DS-COVU-B Change of value reporting)
- Modbus: Bit list - bit 2 or register 31

SummaryAlarm

BMS access: RD
Equipment functions: RR with RMF, TAM with RMF

Function

- Output of a consolidated alarm
- An alarm signal is generated when a controller emits an alarm or fault message.
- Alarm conditions can be defined using the EasyConnect configuration software
- Standard configuration: volume flow rate alarm

Functional values

- 0 = No consolidated alarm
- 1 = Consolidated alarm

Data point

- BACnet: Binary Value Object - Instance 2 – (BIBBS-DS-COVU-B Change of value reporting)
- Modbus: Bit list - bit 3 or register 32

PressAlarm

BMS access: RD

Equipment functions: RR with RMF, TAM with RMF

Function

- Output of a room pressure alarm when room pressure control is active
- Alarm conditions can be defined using the EasyConnect configuration software

Functional values

- 0 = No differential pressure alarm
- 1 = Differential pressure alarm

Data point

- BACnet: Binary Value Object - Instance 3 – (BIBBS-DS-COVU-B Change of value reporting)
- Modbus: Bit list - bit 4 or register 33

SystemDevices

BMS access: RD

Equipment functions: FH, RR, TAM, RR with RMF, TAM with RMF

Function

- Number of EASYLAB system components identified

Data point

- BACnet: Analog Value Object - Instance 21
- Modbus Register 37

DI1 ... DI6 (status of digital inputs)

BMS access: RD

Equipment functions: FH, RR, TAM, RR with RMF, TAM with RMF

Function

- States of digital inputs DI1 ... DI6 of the controller or adapter module

Data point

- BACnet: Binary Value Object - Instance 6 (DI1) ... Instance 11 (DI6), 0 = active, 1 = inactive
- Modbus: Register 39 – bit 0 (DI1) ... bit 5 (DI6), bit not set = inactive, bit set = active

DO1 ... DO6 (state of digital outputs)

BMS access: RD

Equipment functions: FH, RR, TAM, RR with RMF, TAM with RMF

Function

- States of digital outputs DO1 ... DO6 of the controller or adapter module

Data point

- BACnet: Binary Value Object - Instance 12(DO1) ... Instance 17 (DO6), 0 = output inactive, 1 = output active
- Modbus: Register 40 - bit 0 (DO1) ... bit 5 (DO6), bit not set = output inactive, bit set = output active

Read Device Identification (only Modbus)

BMS access: RD

Equipment functions: FH, RR, TAM, RR with RMF, TAM with RMF

Function

- Provides status information for the Modbus device

Data point

BACnet : see Device Object description

- Modbus: Device response
- Byte 0: Slave Address 1-99
- Byte 1: Function Code 0x2B
- Byte 2: MEI-Type 0x0E
- Byte 3: Read Device ID Code 0x01
- Byte 4: Conformity Level 0x01
- Byte 5: More Follows 0x00
- Byte 6: Next Object ID 0x00
- Byte 7: Number of Objects 0x03
- Byte 8: ID: VendorName 0x00
- Byte 9: Obj-Length 9
- Byte 10-18: Obj-Value "TROX GmbH"
- Byte 19 ID: ProductCode 0x01
- Byte 20: Obj-Length 23
- Byte 21-43: Obj-Value "EM-BAC-MOD-01 - EASYLAB"
- Byte 44 ID: MajMinRevision 0x02
- Byte 45: Obj-Length 4
- Byte 46-49: Obj-Value "V2.0"

DampPos

BMS access: RD

Equipment functions: FH, RR, RR with RMF

Unit: Percentage value in increments of 0.5 %

Function

- Output of the damper blade position¹

Data point

- BACnet: Analog Value Object - Instance 10
- Modbus: Register 14

DampPosMax_FH

BMS access: RD

Equipment functions: FH, RR, TAM, RR with RMF, TAM with RMF

Unit: Percentage value in increments of 0.5 %

Function

- Output of the damper blade position of the fume cupboard controller with the widest open damper blade 1, 2, 4
- For the evaluation of the damper blade positions in separate extract air systems (2 fans), i.e. fume cupboard extract air and room extract air

Data point

- BACnet: Analog Value Object - Instance 11 – value and event state
- Modbus: Register 15 (value) and register 16 (event state)

DampPosMin_FH

BMS access: RD

Equipment functions: FH, RR, TAM, RR with RMF, TAM with RMF

Unit: Percentage value in increments of 0.5 %

Function

- Output of the damper blade position of the fume cupboard controller with the least wide open damper blade 1, 2, 5
- For the evaluation of the damper blade positions in separate extract air systems (2 fans), i.e. fume cupboard extract air and room extract air

Data point

- BACnet: Analog Value Object - Instance 12 – value and event state
- Modbus: Register 17 (value) and register 18 (event state)

DampPosMax_RE

BMS access: RD

Equipment functions: FH, RR, TAM, RR with RMF, TAM with RMF

Unit: Percentage value in increments of 0.5 %

Function

- Output of the damper blade position of the room extract air controller with the widest open damper blade 1, 2, 4
- For the evaluation of the damper blade positions in separate extract air systems (2 fans), i.e. fume cupboard extract air and room extract air

Data point

- BACnet: Analog Value Object - Instance 13 – value and event state
- Modbus: Register 19 (value) and register 20 (event state)

DampPosMin_RE

BMS access: RD

Equipment functions: FH, RR, TAM, RR with RMF, TAM with RMF

Unit: Percentage value in increments of 0.5 %

Function

- Output of the damper blade position of the room extract air controller with the least wide open damper blade 1, 2, 5
- For the evaluation of the damper blade positions in separate extract air systems (2 fans), i.e. fume cupboard extract air and room extract air

Data point

- BACnet: Analog Value Object - Instance 14 – value and event state
- Modbus: Register 21 (value) and register 22 (event state)

DampPosMax_TE

BMS access: RD

Equipment functions: FH, RR, TAM, RR with RMF, TAM with RMF

Unit: Percentage value in increments of 0.5 %

Function

- Output of the damper blade position of the fume cupboard or room extract air controller with the widest open damper blade 1, 3, 4
- For the evaluation of the damper blade positions in the extract air system (1 fan) for fume cupboard and room extract air

Data point

- BACnet: Analog Value Object - Instance 15 – value and event state
- Modbus: Register 23 (value) and register 24 (event state)

DampPosMin_TE

BMS access: RD

Equipment functions: FH, RR, TAM, RR with RMF, TAM with RMF

Unit: Percentage value in increments of 0.5 %

Function

- Output of the damper blade position of the fume cupboard or room extract air controller with the least wide open damper blade 1, 3, 5
- For the evaluation of the damper blade positions in the extract air system (1 fan) for fume cupboard and room extract air

Data point

- BACnet: Analog Value Object - Instance 16 – value and event state
- Modbus: Register 25 (value) and register 26 (event state)

DampPosMax_RS

BMS access: RD

Equipment functions: FH, RR, TAM, RR with RMF, TAM with RMF

Unit: Percentage value in increments of 0.5 %

Function

- Output of the damper blade position of the room supply air controller with the widest open damper blade 1, 4

Data point

- BACnet: Analog Value Object - Instance 17 – value and event state
- Modbus: Register 27 (value) and register 28 (event state)

DampPosMin_RS

BMS access: RD

Equipment functions: FH, RR, TAM, RR with RMF,
TAM with RMF

Unit: Percentage value in increments of 0.5 %

Function

- Output of the damper blade position of the room supply air controller with the least wide open damper blade 1, 5

Data point

- BACnet: Analog Value Object - Instance 18 – value and event state
- Modbus: Register 29 (value) and register 30 (event state)

1 Damper blade positions nvoDampPosXX_XX are transmitted as a percentage value between 0 % (closed) and 100 % (open).

2 The output variables nvoDampPosMax_FH, nvoDampPosMin_FH as well as nvoDampPosMax_RE and nvoDampPosMin_RE are provided for the evaluation of the damper blade positions in separate extract air systems (2 fans), i.e. fume cupboard extract air and room extract air

3 The output variables nvoDampPosMax_TE and nvoDampPosMin_TE are provided for the evaluation of the damper blade positions in the extract air system (1 fan) for fume cupboard and room extract air.

4 Status information for the damper blade positions nvoDampPosMax_XX

- Event state = 0: All damper blades in standard operating mode. Override possible
- Event state = -1 (FF): All damper blades in OPEN mode (special operating mode, value = 100 %). Override not possible
- Event-state = 1: At least one damper blade in OPEN mode (special operating mode)

5 Status information for the damper blade positions nvoDampPosMin_XX

- Event state = 0: All damper blades in standard operating mode. Override possible
- Event state = -1 (FF): All damper blades in shut-off mode (special operating mode, value = 0 %). Override not possible
- Event-state = 1:1 At least one damper blade in shut-off mode (special operating mode)

Standard text

Expansion module to supplement an EASYLAB base component (controller TCU3 or adapter module TAM) with a BACnet or Modbus interface to link rooms or individual volume flow controllers to the central BMS.

The expansion module includes an interface for EIA-485 networks that can be used for BACnet MS/TP or Modbus RTU (switching), a switch to enter communication parameters, a connection to update the firmware, and indicator lights.

Special features

- Ready for installation, can be easily connected to the main PCB
- Interface for EIA-485 networks BACnet MS/TP and Modbus RTU
- BACnet Protocol Revision 12.0
- Only standard BACnet objects or Modbus registers are used for communication
- Data interface for an EASYLAB controller or for an EASYLAB room with different functional profiles
- Hardware switch to enter network addresses and communication parameters (no communication software required)

Technical data

- Communications interface: EIA-485 standard
- Protokoll: BACnet MS/TP standard rev. 12 or Modbus RTU
- Data transmission speeds: BACnet: 9600, 19200, 38400, 76800 baud, Modbus: 9600, 19200, 38400, 57600 baud
- Parity checks for data security: none, odd, even
- Configurable network addresses: 01 ... 99
- Operating temperature 0 to 50 °C
- IEC protection class: III (protective extra-low voltage)
- Protection level: IP 20
- EC conformity: EMC to 2004/108/EG

Data points for a single controller

- Volume flow actual and setpoint values
- Damper blade position
- Operating mode
- Alarm/status messages
- Total supply air and total extract air actual values (room)
- Evaluated damper blade positions for all controllers in a room
- Number of controllers
- Integration of volume flows

Additional data points for a fume cupboard controller

- Operating mode default setting for the fume cupboard controller equipped with the expansion module
- Selection of priority for operating mode default setting
- Face velocity actual value and setpoint value (only for fume cupboard controllers with face velocity transducer, equipment function FH-VS)

Data points for EASYLAB room

- Operating mode default setting for the room: Just one data point is required to set the default operating mode for all controllers in a room
- Selection of priority for operating mode default setting (central BMS or room)
- Room operating mode
- Volume flow rate setpoint change (by the central BMS, for example) for an external temperature or differential pressure control
- Setpoint value switching for differential pressure control: Switching between two differential pressure setpoint values
- Total supply air and total extract air actual values (room)
- Evaluated damper blade positions for all controllers in a room
- Room differential pressure actual and setpoint values
- Room pressure alarm
- Number of controllers within the EASYLAB system
- Integration of volume flows
- Status of the digital inputs and outputs
- Configurable consolidated alarm (operating statuses, hardware faults)

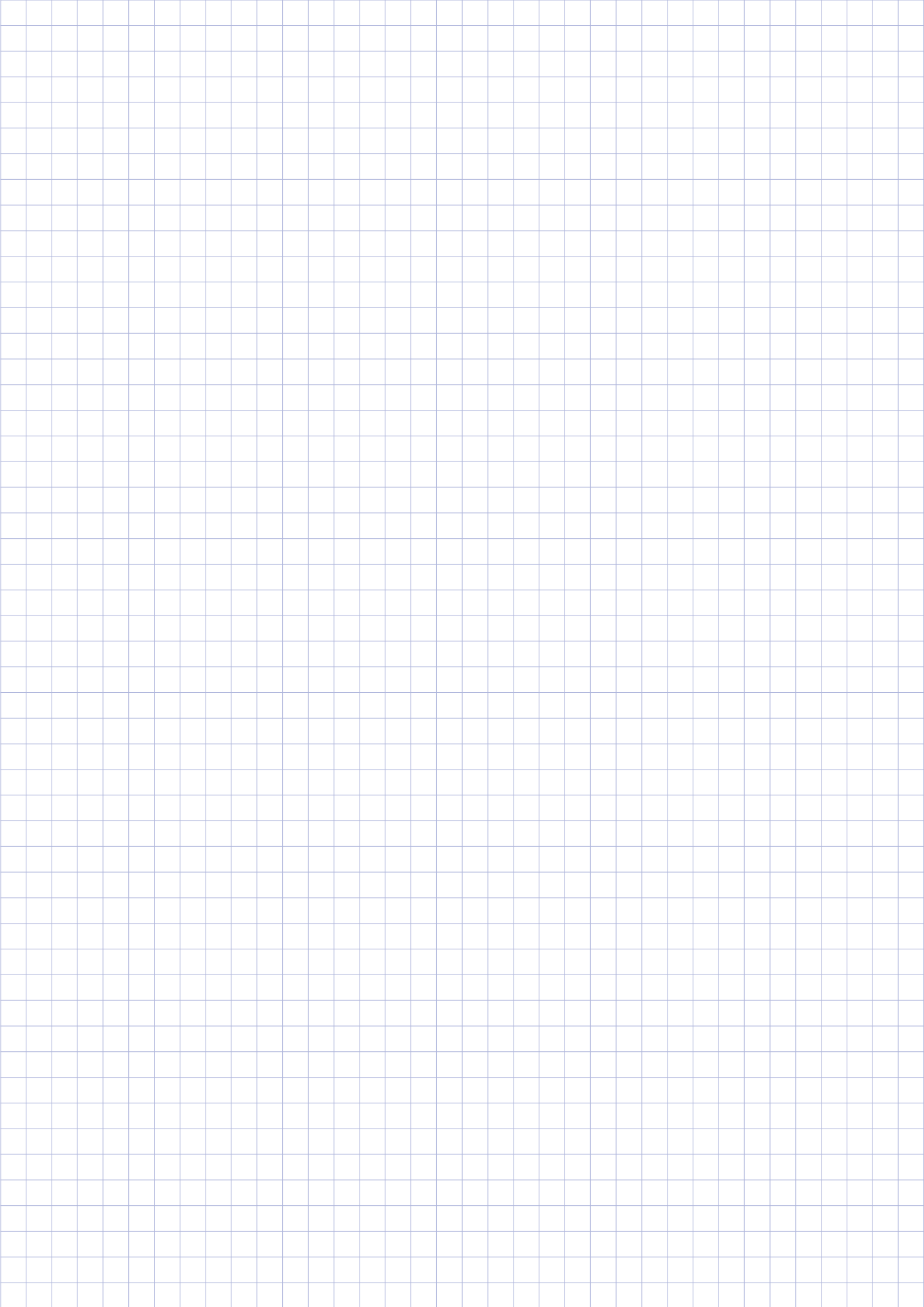

Expansion modules

EM-TRF

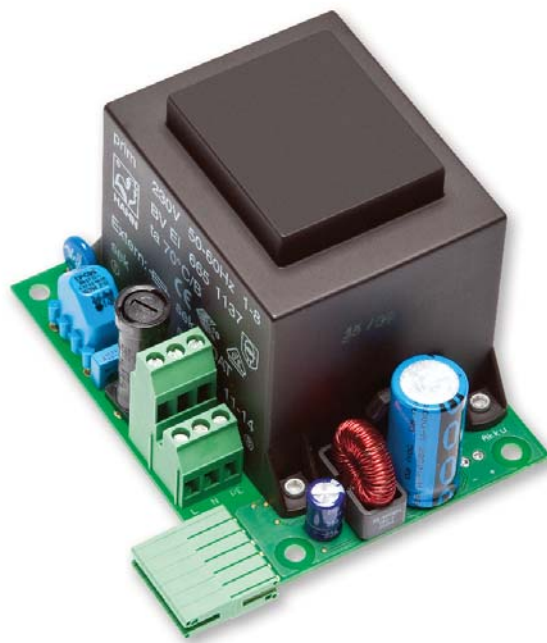

For the connection of EASYLAB to the 230 V mains

Expansion module for the direct connection of EASYLAB controllers Type TCU3 and adapter modules Type TAM to the 230 V mains

- Double-stack terminal blocks for 230 V supply voltage connection
- Electric plug connection to the main PCB
- The expansion module is fitted into the casing with the EASYLAB base component



EASYLAB adapter
module TAM



EASYLAB controller
TCU3

Type		Page
EM-TRF	General information	2.3 – 40
	Specification text	2.3 – 42
	Basic information and nomenclature	2.7 – 1

Description

Application

- Expansion module Type EM-TRF for the EASYLAB system
- For the connection of EASYLAB base components (controller TCU3 or adapter module TAM) to the 230 V AC supply voltage (mains)
- Power supply for the base component and the connected modules
- Factory mounted or for retrofitting into the EASYLAB base component casing

Special features

- Ready for installation, can be easily connected to the main PCB
- Double-stack terminal blocks for 230 V AC supply voltage connection
- Simple electrical connection of expansion module and EASYLAB main PCB using a connection plug
- Simple wiring of switch-operated fume cupboard lighting in combination with the EM-LIGHT expansion module

Parts and characteristics

- Mains transformer 230 V AC (primary), 24 V AC (secondary)
- PCB plug connector to connect the module to the EASYLAB main PCB

Construction features

- PCB dimensions and fixing points correspond to the EASYLAB main PCB and the casing
- Fixing with screws
- Double-stack terminal blocks for simply 230 V supply voltage connection

Installation and commissioning

- As attachment for the EASYLAB base component: factory mounted
- For retrofitting: Mount the expansion module into the base casing
- The EASYLAB controller TCU3 or the adapter module TAM identifies the expansion module automatically

Technical data

Supply voltage	230 V AC \pm 10 %, 50/60 Hz
Power consumption	up to 40 VA for a controller with all expansion modules; up to 35 VA for a fume cupboard controller with control panel; up to 33 VA for a room controller with control panel; up to 29 VA for a room controller without control panel; up to 9 VA for an EASYLAB adapter module TAM
Primary fuse	50 mA slow blow, 250 V
Double-stack terminals	Cable cross-section up to 2.5 mm ²
Operating temperature	0 – 50 °C
IEC protection class	I (protective earth)
Protection level	IP 20
EC conformity	EMC to 2004/108/EG, low voltage to 2006/95/EG
Weight	1.3 kg

Function

EM-TRF

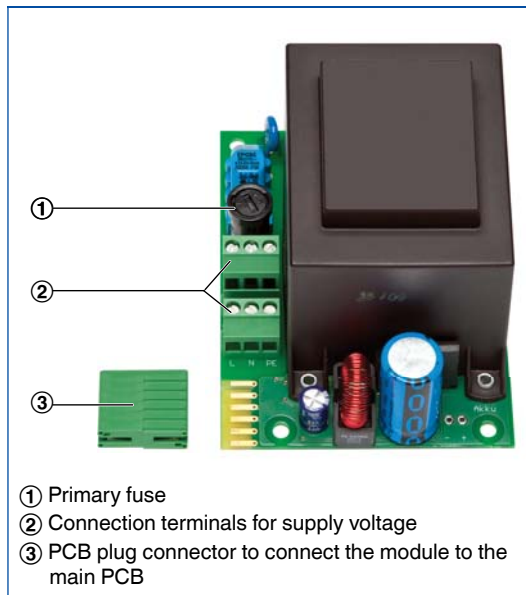

Order code

Any attachments must be defined with the order code of the VAV terminal unit.

Order code detail for control component
ELAB (TCU3) or TAM

ELAB / ... / T... / ...

Retrofit possible.

Expansion module EM-TRF for retrofit

EM-TRF

Standard text

Expansion module for the EASYLAB base component (controller TCU3 or adapter module TAM) that can be directly connected to a 230 V AC supply voltage. The expansion module includes a transformer whose secondary voltage (24 V) is equal to the supply voltage for the controller and the expansion modules connected to it.

Special features

- Ready for installation, can be easily connected to the main PCB
- Double-stack terminal blocks for 230 V AC supply voltage connection
- Simple electrical connection of expansion module and EASYLAB main PCB using a connection plug
- Simple wiring of switch-operated fume cupboard lighting in combination with the EM-LIGHT expansion module

Technical data

- Supply voltage: 230 V AC \pm 10 %, 50/60 Hz
- Power consumption: up to 40 VA for a controller with all expansion modules; up to 35 VA for a fume cupboard controller with control panel; up to 33 VA for a room controller with control panel; up to 29 VA for a room controller without control panel; up to 9 VA for an EASYLAB adapter module TAM
- Double-stack terminals: Cable cross-section up to 2.5 mm²
- Protection level: IP 20

Expansion modules

EM-TRF-USV



For the connection of EASYLAB to the 230 V mains and for uninterruptible power supply

Expansion module for the direct connection of EASYLAB controllers Type TCU3 and adapter modules Type TAM to the 230 V mains, including uninterruptible power supply

- Double-stack terminal blocks for 230 V supply voltage connection
- Electric plug connection to the main PCB
- The expansion module is fitted into the casing with the EASYLAB base component
- Uninterruptible power supply for the connected modules
- Integral battery charging electronics with charge status indicator
- Power failure is signalled to the EASYLAB control panels
- Controller action in case of a power failure can be defined



EASYLAB adapter module TAM



EASYLAB controller TCU3

Type		Page
EM-TRF-USV	General information	2.3 – 44
	Specification text	2.3 – 47
	Basic information and nomenclature	2.7 – 1

Base component TCU3 with expansion module EM-TRF-USV

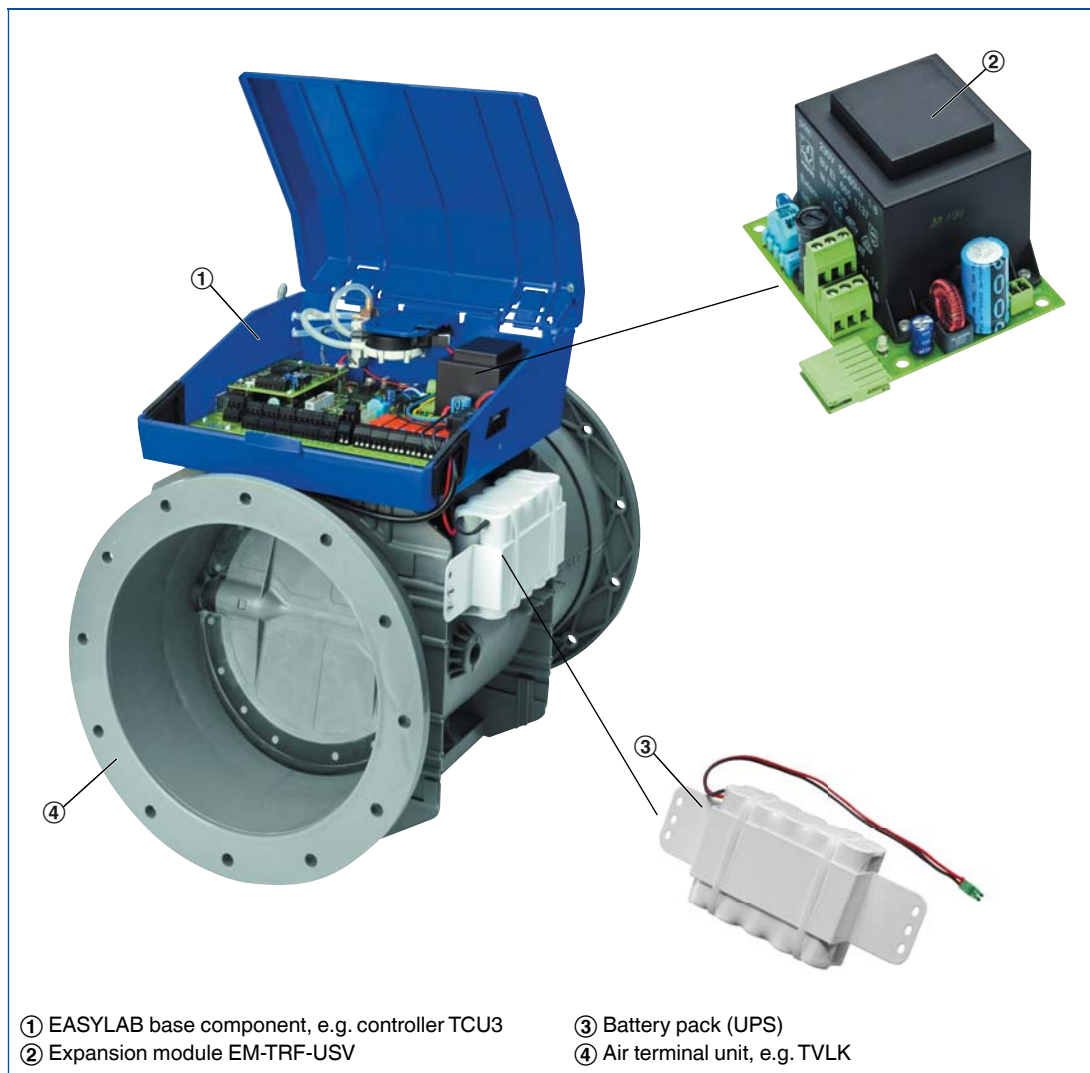

Description

Application

- Expansion module Type EM-TRF-USV for the EASYLAB system
- For the connection of EASYLAB base components (controller TCU3 or adapter module TAM) to the 230 V AC supply voltage (mains)
- Power supply for the base component and the connected modules
- Battery pack ensures uninterrupted power supply even in case of a mains power failure
- Control and/or alarm signalling even in case of a power failure
- Factory mounted or for retrofitting into the EASYLAB base component casing

Useful additions

- EasyConnect: Configuration software for the commissioning and diagnosis of EASYLAB components

Special features

- Ready for installation, can be easily connected to the main PCB
- Double-stack terminal blocks for 230 V AC supply voltage connection
- Simple electrical connection of expansion module and EASYLAB main PCB using a connection plug
- Simple wiring of switch-operated fume cupboard lighting in combination with the EM-LIGHT expansion module
- Intelligent charge control with trickle charging, deep discharge protection, and reverse voltage protection
- Operating state indicator light
- Controlled response in case of a power failure can be defined (EASYLAB TCU3 with expansion module EM-TRF-USV)
- In case of a power failure: Optical signal on the control panel; configurable alarm signalling

Construction features

- PCB dimensions and fixing points correspond to the EASYLAB main PCB and the casing
- Fixing with screws
- Double-stack terminal blocks for simply 230 V supply voltage connection

Installation and commissioning

- As attachment for the EASYLAB base component: factory mounted
- For retrofitting: Mount the expansion module into the base casing, fix battery pack and connect it to the expansion module
- The EASYLAB controller TCU3 or the adapter module TAM identifies the expansion module automatically
- If necessary, adjust the response action and alarm behaviour required in case of a power failure using the EasyConnect configuration software

Parts and characteristics

- Mains transformer 230 V AC (primary), 24 V AC (secondary)
- Intelligent charge control with trickle charging, deep discharge protection, and reverse voltage protection
- Operating state indicator light
- PCB plug connector to connect the module to the EASYLAB main PCB

Technical data

Supply voltage	230 V AC ± 10 %, 50/60 Hz
Primary fuse	50 mA slow blow, 250 V
Power consumption	up to 40 VA for a controller with all expansion modules; up to 35 VA for a fume cupboard controller with control panel; up to 33 VA for a room controller with control panel; up to 29 VA for a room controller without control panel; up to 9 VA for an EASYLAB adapter module TAM
Operation in case of a power failure	One controller (TCU3 or TAM) with control panel, standard operation will be maintained for approx. 4.5 h, defined damper blade positions and power failure signalling will be maintained for approx. 6 h
Battery pack charging	1500 mAh
Battery life	up to 4 years; when stored without trickle charging, 6 months
Double-stack terminals	Cable cross-section up to 2.5 mm ²
Operating temperature	0 – 50 °C
IEC protection class	I (protective earth)
Protection level	IP 20
EC conformity	EMC to 2004/108/EG, low voltage to 2006/95/EG
Weight	2.4 kg (including 1.1 kg for battery pack)

Function

EM-TRF-USV

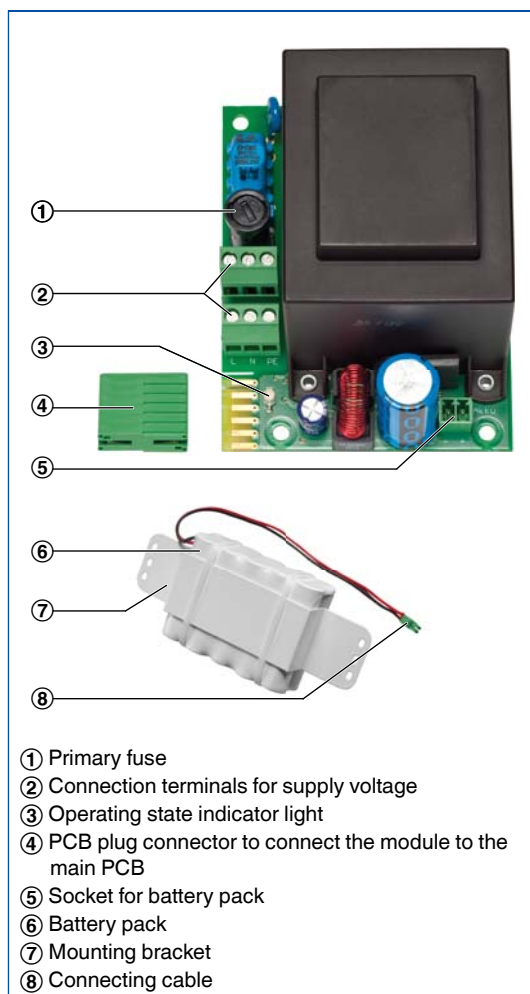

Order code

Any attachments must be defined with the order code of the VAV terminal unit.

Order code detail for control component
ELAB (TCU3) or TAM

ELAB / ... / U... / ...

Retrofit possible.

Expansion module EM-TRF-USV for retrofit

EM-TRF-USV

Standard text

Expansion module for the EASYLAB base component (controller TCU3 or adapter module TAM) that can be directly connected to a 230 V AC supply voltage. The expansion module includes a transformer whose secondary voltage (24 V) is equal to the supply voltage for the controller and the expansion modules connected to it.

Uninterruptible power supply (UPS) by means of a battery pack that maintains defined functions in case of a power failure.

Special features

- Ready for installation, can be easily connected to the main PCB
- Double-stack terminal blocks for 230 V AC supply voltage connection
- Simple electrical connection of expansion module and EASYLAB main PCB using a connection plug
- Simple wiring of switch-operated fume cupboard lighting in combination with the EM-LIGHT expansion module
- Intelligent charge control with trickle charging, deep discharge protection, and reverse voltage protection
- Operating state indicator light
- Controlled response in case of a power failure can be defined (EASYLAB TCU3 with expansion module EM-TRF-USV)
- In case of a power failure: Optical signal on the control panel; configurable alarm signalling

Technical data

- Supply voltage: 230 V AC \pm 10 %, 50/60 Hz
- Power consumption: up to 40 VA for a controller with all expansion modules; up to 35 VA for a fume cupboard controller with control panel; up to 33 VA for a room controller with control panel; up to 29 VA for a room controller without control panel; up to 9 VA for an EASYLAB adapter module TAM
- Operation in case of a power failure: One controller (TCU3 or TAM) with control panel, standard operation will be maintained for approx. 4.5 h, defined damper blade positions and power failure signalling will be maintained for approx. 6 h
- Battery pack charging: 1500 mA
- Battery life: up to 4 years
- Double-stack terminals: Cable cross-section up to 2.5 mm²
- Protection level: IP 20



Expansion modules

EM-AUTOZERO

2



Automatic zero point correction for EASYLAB

Expansion module for EASYLAB controllers that offers automatic zero point correction for long-term stable volume flow rate measurement and reduced maintenance

- Particularly recommended for the volume flow or differential pressure measurement in sensitive areas
- EASYLAB controller automatically identifies and uses the expansion module
- The expansion module is fitted into the casing with the EASYLAB base component
- Easy retrofitting
- No additional configuration effort

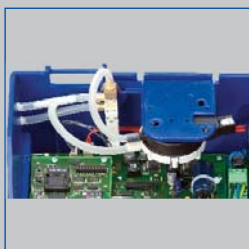

EASYLAB controller including EM-AUTOZERO

Type		Page
EM-AUTOZERO	General information	2.3 – 50
	Specification text	2.3 – 52
	Basic information and nomenclature	2.7 – 1

Description



Expansion module EM-AUTOZERO

Application

- Expansion module Type EM-AUTOZERO for the EASYLAB system
- EM-AUTOZERO, automatic zero point correction for long-term stable volume flow rate measurement and reduced maintenance.
- Can be used with fume cupboard, supply air, extract air or differential pressure controller EASYLAB TCU3
- For use in laboratories, clean rooms in the pharmaceutical and semiconductor industries, operation theatres, intensive care units, and offices with very demanding control requirements

Special features

- Long-term stable volume flow rate measurement and reduced maintenance
- Automatic zero point correction as soon as the supply voltage is applied
- Cyclical zero point correction during operation (every 8 hours)
- No additional configuration effort
- The EASYLAB controller identifies the expansion module automatically

Parts and characteristics

- Solenoid valve
- Plug-in connection cable for the connection to the EASYLAB main PCB
- Tubes for the connection of the static differential pressure transducer

Construction features

- Dimensions and fixing correspond to the EASYLAB casing
- The expansion module is inserted into a recess of the holder for the differential pressure transducer (no tools required)
- Integration with the tube connection between the static differential pressure transducer and the differential pressure sensor
- Plug ensures easy connection to the EASYLAB controller

Installation and commissioning

- As attachment for the EASYLAB base component: factory mounted
- For retrofitting: Mount the expansion module into the base casing and connect it

Technical data

Supply voltage	24 V DC from the controller TCU3
Power rating	1.8 W
Maximum pressure	10 bars
Operating temperature	0 – 50 °C
IEC protection class	III (protective extra-low voltage)
Protection level	IP 20
EC conformity	EMC according to 2004/108/EG
Weight	0.10 kg

Function

The solenoid valve of the EM-AUTOZERO expansion module is integrated with the tube connection between the static differential pressure transducer and the differential pressure sensor of the VAV terminal unit.

The TCU3 controller provides the control input signal for cyclical zero point corrections.

For this purpose, the measuring tubes of the differential pressure transducer are temporarily short circuited, then the zero voltage is measured. This measured value is used as a correction value for the volume flow rate measurement until the next zero point correction.

EM-AUTOZERO

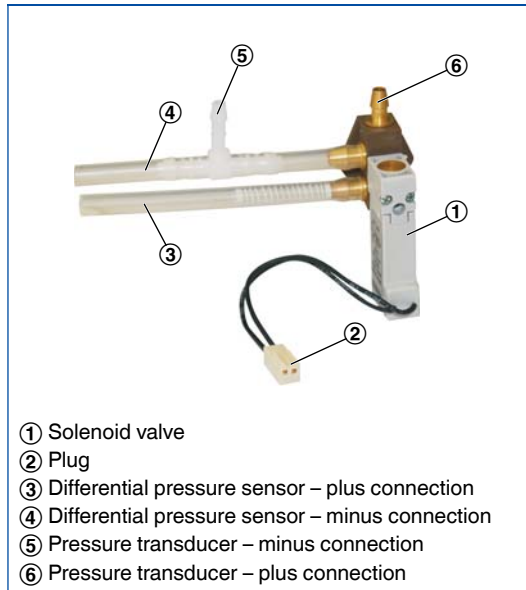

Order code

Any attachments must be defined with the order code of the VAV terminal unit.

Order code detail for control component ELAB (TCU3) or TAM

ELAB / ...Z... / ...

Retrofit possible.

Expansion module EM-AUTOZERO for retrofit

EM – AUTOZERO

Standard text

Expansion module for the EASYLAB controller TCU3, used for automatic zero point correction.
Long-term stable volume flow rate measurement and reduced maintenance.
The expansion module comprises a solenoid valve, the connection cable and connection tubes.

Special features

- Long-term stable volume flow rate measurement and reduced maintenance
- Automatic zero point correction as soon as the supply voltage is applied
- Cyclical zero point correction during operation (every 8 hours)
- No additional configuration effort
- The EASYLAB controller identifies the expansion module automatically

Technical data

- Solenoid valve
- Supply voltage 24 V DC from the controller TCU3
- Power rating 1.8 W
- Maximum pressure 10 bars
- Protection level IP 20

Expansion modules

EM-LIGHT

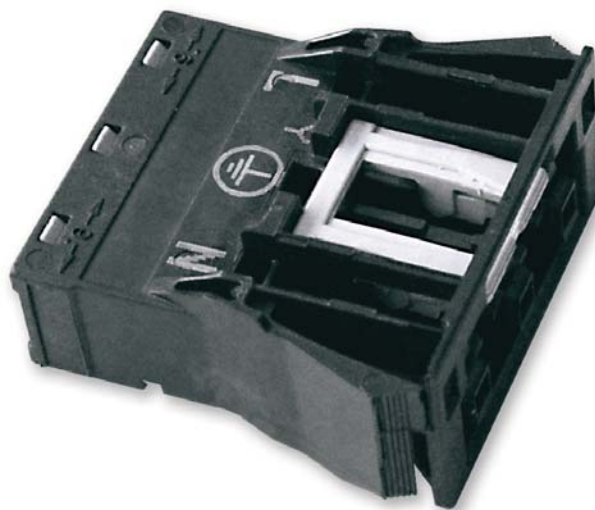

For the simple connection of lighting to an EASYLAB fume cupboard controller

Expansion module with a wired socket for the connection of lighting and for switching the lighting on/off using the control panel

- Lighting can be switched on/off using an EASYLAB control panel
- Socket for the connection of fume cupboard or room lighting (230 V)
- Only in connection with expansion module EM-TRF or EM-TRF-USV
- Socket on the outside of the controller casing
- Plug-in connection for the lighting, e.g. fume cupboard lighting



Buttons on the control panel to switch the lighting on/off



Connection socket for lighting

Type		Page
EM-LIGHT	General information	2.3 – 54
	Specification text	2.3 – 56
	Basic information and nomenclature	2.7 – 1

Description



Expansion module EM-LIGHT

Application

- Expansion module Type EM-LIGHT for the EASYLAB system
- Simple connection of lighting (230 V) to a wired socket on the controller casing
- Control of fume cupboard lighting using the control panel
- For fume cupboard controllers EASYLAB TCU3 with expansion module EM-TRF or EM-TRF-USV
- Use for fume cupboards

Useful additions

- EasyConnect: Configuration software for the commissioning and diagnosis of EASYLAB components

Special features

- Control of fume cupboard lighting using the control panel
- Simple connection of lighting to a wired socket on the controller casing
- Socket is on the outside of the casing; the casing need not be opened
- Plug-in connection cable of the fume cupboard lighting is simply connected to the socket

Parts and characteristics

- Socket WAGO WINSTA Midi, 770 series
- Socket with plug-in connection cables, 230 V

Construction features

- Socket suitable for the dedicated opening in the controller casing
- Push-in type socket, no tools required
- Cables suitable for connection to TCU3 in combination with EM-TRF or EM-TRF-USV
- Cables with wire end sleeves and text labels for marking the terminals to be used

Installation and commissioning

- As attachment for the EASYLAB base component: factory mounted
- For retrofitting: Mount the expansion module into the base casing and connect it
- Use EasyConnect configuration software to activate control panel button for lighting

Technical data

Supply voltage	230 V AC, connection to EM-TRF or EM-TRF-USV
Max. switching current	12 A; switch-on current 25 A max.
Operating temperature	0 – 50 °C
IEC protection class	I (protective earth)
Protection level	IP 20
EC conformity	EMC to 2004/108/EG, low voltage to 2006/95/EG

Function

The expansion module EM-LIGHT provides a socket (WAGO WINSTA Midi, 770 series) for the connection of lighting using a plug-in cable. For this purpose, the expansion module is connected to the terminals of the EM-TRF or EM-TRF-USV for 230 V AC and to a digital output of the controller TCU3. The lighting can then be switched on/off using the control panel.

EM-LIGHT

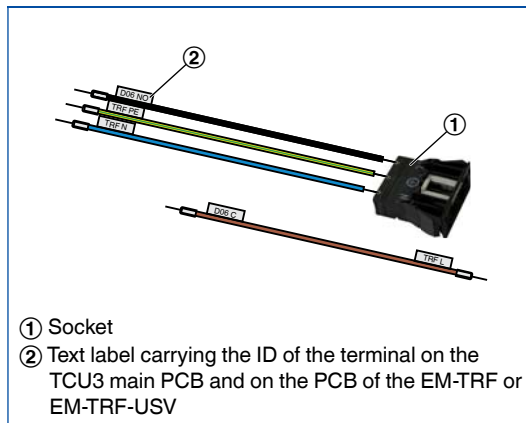

Order code

Any attachments must be defined with the order code of the VAV terminal unit.

Order code detail for control component
ELAB (TCU3) or TAM

ELAB / ... / ...S / ...

Retrofit possible.

Lighting connecting socket EM-LIGHT, for retrofit

EM - LIGHT

Standard text

Expansion module for the EASYLAB controller TCU3 (connected to 230 V), for the simple connection of lighting to a wired socket (230 V)

Control of lighting (typically fume cupboard lighting) using the control panel.

Special features

- Control of fume cupboard lighting using the control panel
- Simple connection of lighting to a wired socket on the controller casing
- Socket is on the outside of the casing; the casing need not be opened
- Plug-in connection cable of the fume cupboard lighting is simply connected to the socket

Technical data

- Supply voltage 230 V AC, connection to EM-TRF or EM-TRF-USV
- Switching current 12 A max.
- Operating temperature 0 ... +50 °C
- Protection level IP 20

Type		Page
VS-TRD	General information	2.4 – 2
	Specification text	2.4 – 5
	Basic information and nomenclature	2.7 – 1

Description



Face velocity transducer
Type VS-TRD

Application

- Face velocity transducer Type VS-TRD for the LABCONTROL system
- For the demand-based control of variable volume flows in fume cupboards
- Connection to an EASYLAB controller TCU3, to a controller TCU-LON-II, or to monitoring systems TFM-2-TPM
- Consideration of all sashes of a fume cupboard
- For fume cupboards with vertical and horizontal sashes, also for fume cupboards with sashes on two sides
- Increased safety for people working in labs
- For use in laboratories and in clean rooms in the pharmaceutical and semiconductor industries

Useful additions

- CAB-TRD: 5 m plug-in extension cable for face velocity transducer VS-TRD
- EasyConnect: Configuration software for the commissioning and diagnosis of EASYLAB components
- MConnect: Configuration software for the commissioning and diagnosis of the Type TFM/TPM monitoring devices and TCU-LON-II

Special features

- Demand-based fume cupboard control depending on the sash distance
- Recording of the face velocity at vertical and horizontal sashes as well as for both sashes on a fume cupboard
- Non-contact measurement of the face velocity, hence not subject to wear
- Constant face velocity (typically 0.5 m/s) within the set volume flow rate range due to cascade control of face velocity and volume flow
- Detection and safe dissipation of thermal loads due to automatic volume flow increase

Parts and characteristics

- Easy-to-install casing with sensor tube
- Sensitive electronics with integral temperature compensation
- Non-contact measurement of the face velocity using calorimetric principle; not subject to wear

Construction features

- Simple mounting to fume cupboards
- Conical sensor tube to be inserted into a drilled hole 21 – 22.5 mm in the dome of the fume cupboard
- Plug-in connecting cable 3 m

Materials and surface

- Plastic casing, black

Installation and commissioning

- Not to be installed near a ceiling diffuser
- Not to be installed in pressurised ceiling voids
- Access must be ensured
- EASYLAB controller TCU3: The controller automatically recognises the face velocity transducer (equipment function FH-VS)
- Controller TCU-LON-II: The controller automatically recognises the face velocity transducer (equipment function FH)
- Monitoring system TFM-2: Integrate the face velocity transducer using the MConnect configuration software
- If necessary, make project-specific adjustments using the configuration software

Standards and guidelines

- Type certification: Volume flow control system for fume cupboards to EN 14175

Technical data

Supply voltage	24 V AC/DC from the controller
Measuring range	0 – 1 m/s
Actual value signal output	2 – 10 V DC
Operating temperature	15 – 40 °C
IEC protection class	III (protective extra-low voltage)
Protection level	IP 20
EC conformity	EMC according to 2004/108/EG

Function

Functional description

The face velocity is measured using a heated thermal resistor and based on the resistance change principle; it is a non-contact measurement and hence not subject to wear. The face velocity sensor is placed in a bypass opening where it measures the airflow. This airflow is equal to the face velocity of all sashes of the fume cupboard. The face velocity transducer can thus be used for both vertical and horizontal sashes.

VS-TRD for fume cupboard control

- EASYLAB controller TCU3: Equipment function FH-VS
- Controller TCU-LON-II: Equipment function FH

Since cascade control applies, the face velocity is kept constant based on the volume flow rate, which lies between the set minimum and maximum volume flow rates.

Opening the sash leads to a decrease of the face velocity. The fume cupboard controller raises the volume flow. Sufficient air transfer from the room to the fume cupboard is ensured (and work safety is maintained).

Closing the fume cupboard leads to a decrease of the volume flow such that the face velocity is kept constant. The minimum volume flow ensures sufficient ventilation of the fume cupboard.

VS-TRD for monitoring

- Monitoring system TFM-2

The face velocity is monitored. If the face velocity is above or below a certain limit, an alarm is emitted on the control panel. Limits and the type of alarm can be configured.

Function

Sash closed. High face velocity

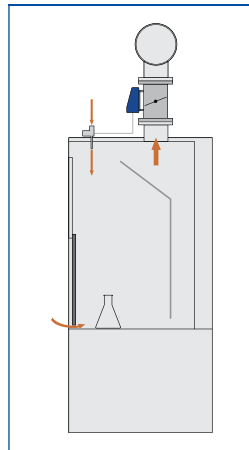

Sash open. Low face velocity

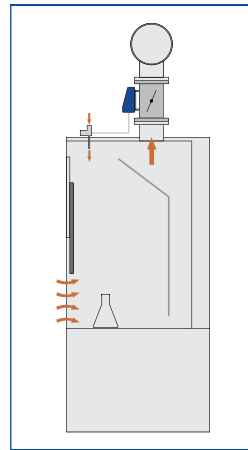

Control diagram for FH-VS (EASYLAB) and FH (TCU-LON-II)

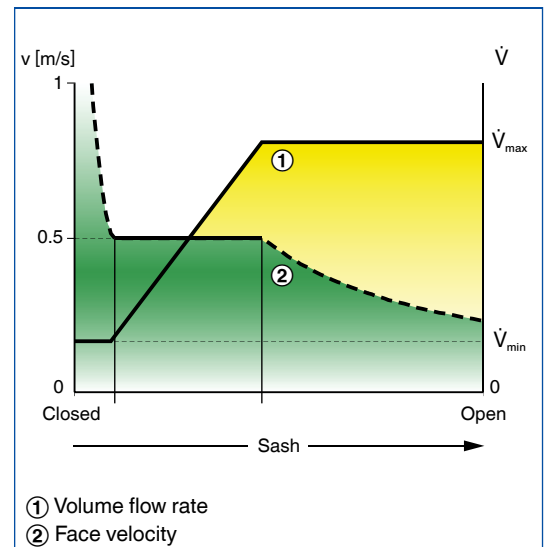

Order code

Any attachments must be defined with the order code of the VAV terminal unit.

Order code detail for control components ELAB (EASYLAB controller), TCU-LON-II controller TMA, TMB with equipment function fume cupboard control FH

**ELAB / FH - VS / ...
TM* / FH / ...**

Retrofit possible.

Transducer VS-TRD for retrofit or as replacement part

VS - TRD

Dimensions

Dimensional drawing of VS-TRD

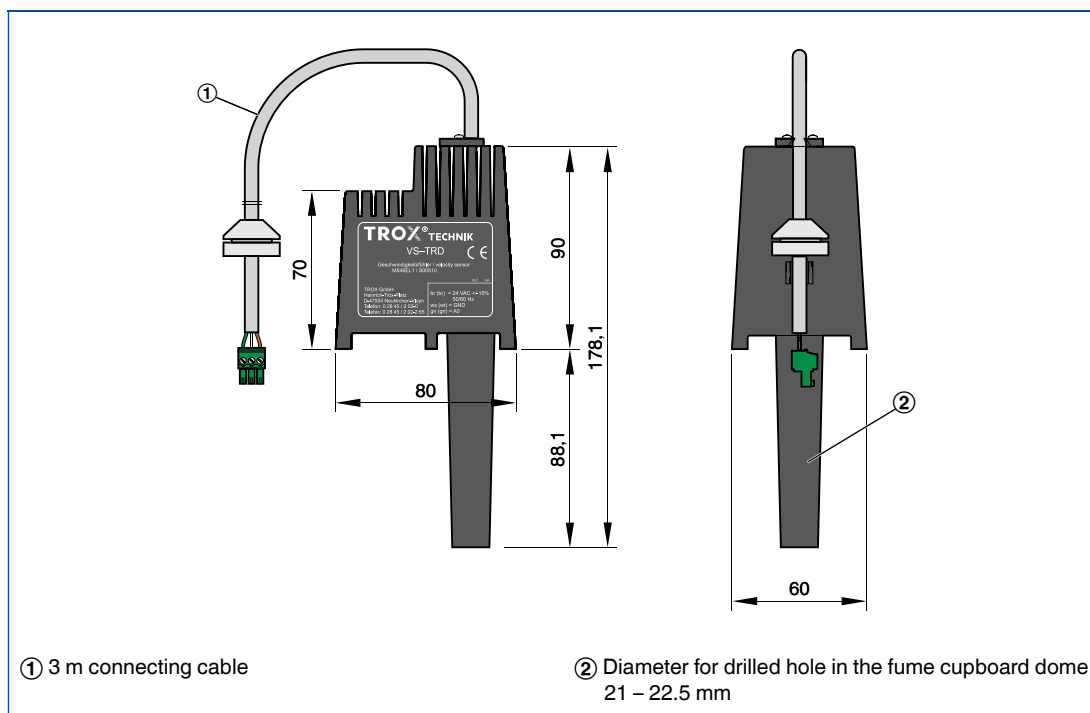

Installation and commissioning

Measurement location of the face velocity transducer (FH-VS, FH)

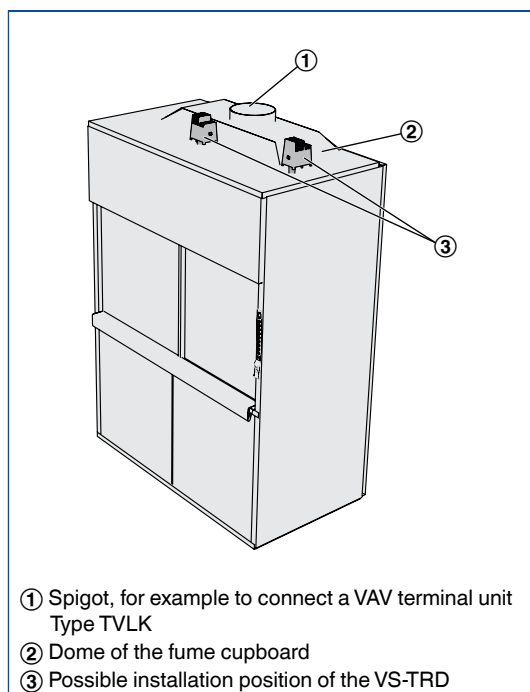

Standard text

Electronic transducer for the LABCONTROL system, used to measure the face velocity on fume cupboards.

Suitable for fume cupboards with vertical and horizontal sashes.

Non-contact measurement, not subject to wear.

A 0 – 10 V DC voltage signal that is proportional to the face velocity is emitted. If the transducer is connected to a fume cupboard controller, the volume flow is controlled based on demand. If the transducer is connected to a monitoring system, an alarm is emitted in case the face velocity is higher or lower than the set maximum and minimum values.

Simple mounting on the fume cupboard dome.

Special features

- Demand-based fume cupboard control depending on the sash distance
- Recording of the face velocity at vertical and horizontal sashes as well as for both sashes on a fume cupboard
- Non-contact measurement of the face velocity, hence not subject to wear
- Constant face velocity (typically 0.5 m/s) within the set volume flow rate range due to cascade control of face velocity and volume flow
- Detection and safe dissipation of thermal loads due to automatic volume flow increase

Materials and surface

- Plastic casing, black

Technical data

- Supply voltage: 24 V DC from the controller
- Measuring range: 0 – 1 m/s
- Output: Actual value signal: 2 – 10 V
- Protection level: IP 20



Sensor systems

Type DS-TRD-01



For EASYLAB fume cupboard controllers

Sash distance sensor for the variable, demand-based control of extract air flows in fume cupboards

- Sash distance measurement
- For fume cupboards with vertical sashes only; also for walk-in fume cupboards
- Ideal for rooms with high airflow velocities or levels of turbulence
- Multiple possibilities to couple the sensor with the sash movement
- Measuring range 0 – 1750 mm or 350 – 2100 mm

Type		Page
DS-TRD-01	General information	2.4 – 8
	Specification text	2.4 – 12
	Basic information and nomenclature	2.7 – 1

Description



Sash distance sensor
Type DS-TRD-01

Application

- Sash distance sensor Type DS-TRD-01 for fume cupboard controllers EASYLAB TCU3
- For the demand-based control of variable volume flows in fume cupboards, based on the sash distance
- For linear control (FH-DS) and safety-optimised control (FH-DV) by the EASYLAB controller
- For fume cupboards with vertical sashes only; also for walk-in fume cupboards
- Ideal for rooms with high airflow velocities or levels of turbulence (measurement of the sash distance, the volume flow rate measurement is therefore not affected)
- For use in laboratories and in clean rooms in the pharmaceutical and semiconductor industries

Useful additions

- EasyConnect: Configuration software for the commissioning and diagnosis of EASYLAB components

Special features

- Suitable for sashes with 1750 mm maximum opening
- Suitable for EASYLAB controller TCU3
- Can be used with different control strategies (FH-DS and FH-DV)
- Ideal for rooms with high airflow velocities or levels of turbulence
- Replaces a separate contact for sash distance monitoring according to EN 14175

Parts and characteristics

- Measuring wire sensor in a closed casing with integral rewind and precise resistance measurement
- Measuring wire with fixing eye, maximum length 2100 mm
- Mounting bracket for various application situations
- 3 m connecting cable

Construction features

- A draw wire is used to measure the sash distance

Materials and surface

- Plastic casing, black
- Measuring wire made of stainless steel, with a polyamide jacket
- Mounting bracket made of galvanised sheet steel

Installation and commissioning

- Fix the sash distance sensor to the fume cupboard
- Link the measuring wire to the sash movement, e.g. by fixing it to the balance weight of the sash
- The measuring wire can be drawn vertically or horizontally.
- Measuring range 0 – 1750 mm or 350 – 2100 mm
- The controller automatically recognises the sash distance sensor
- Project-specific adjustments can be made, and the maximum operational sash opening can be entered using the EasyConnect configuration software

Standards and guidelines

- Type certification: Volume flow control system for fume cupboards to EN 14175
- Alarm function to EN 14175 if the sash distance limit is exceeded

Technical data

Supply voltage	12 V AC/DC from the controller
Measuring range	0 – 1750 mm or 350 – 2100 mm
Measurement accuracy	± 0.25 % of the reading
Actual value signal output	0 – 10 V DC, max. 0,5 mA
Operating temperature	–20 to +40 °C
IEC protection class	III (protective extra-low voltage)
Protection level	IP 40
EC conformity	EMC according to 2004/108/EG

Function

Functional description

The sash opening is recorded with a draw wire that is linked to the sash movement. The output signal is proportional to the sash opening. The sensor can be used only with vertical sashes.

DS-TRD for fume cupboard control – linear control strategy

- EASYLAB controller TCU3: Equipment function FH-DS
- Variable volume flow control based on the measured sash distance
- Volume flow rate is linear to the sash position: OPEN corresponds to \dot{V}_{max} , CLOSED corresponds to \dot{V}_{min}
- Sash opening can be monitored according to EN 14175, without additional switch contact

DS-TRD for fume cupboard control – safety-optimised control strategy

- EASYLAB controller TCU3: Equipment function FH-DV
- Safety-optimised volume flow control based on the measured sash distance
- The volume flow rate is linear to the sash distance; the aim is to maintain a constant safe face velocity (0.5 m/s) even if the sash is fairly wide open
- Sash opening can be monitored according to EN 14175, without additional switch contact

DS-TRD-01 sash distance sensor

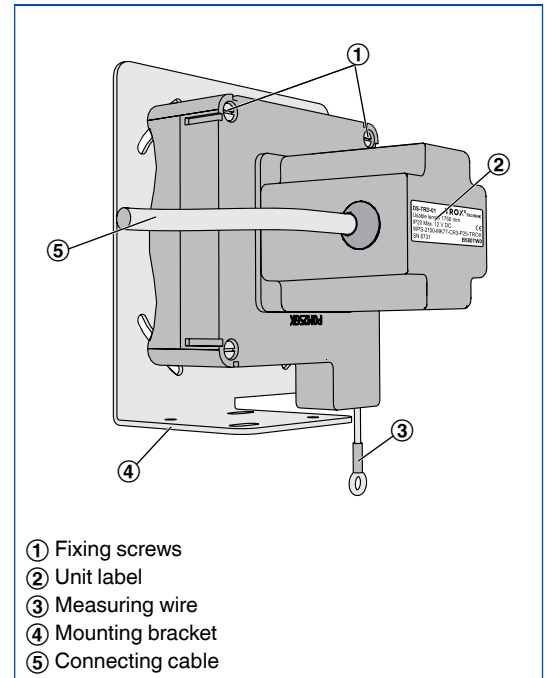

Control diagram for FH-DS

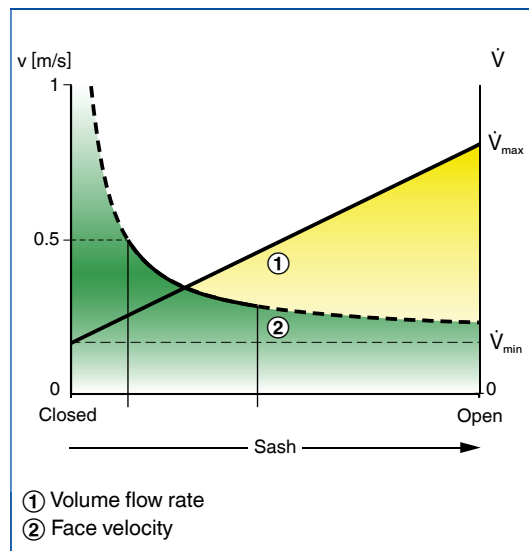

Control diagram for FH-DV

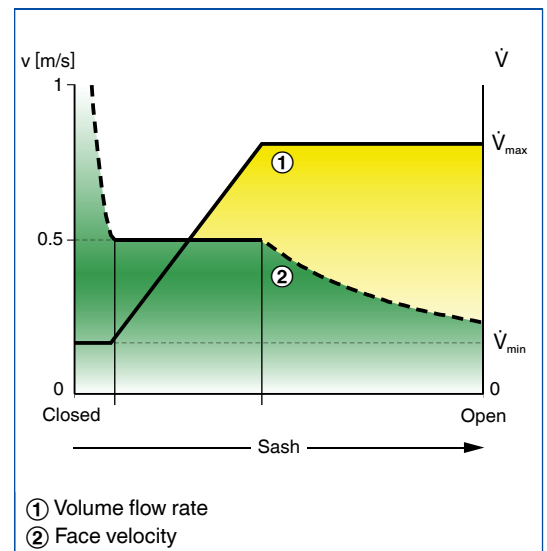

Order code

Any attachments must be defined with the order code of the VAV terminal unit.

Order code for control component ELAB and EASYLAB fume cupboard controllers with linear control strategy (FH-DS) or safety-optimised control strategy (FH-DV)

ELAB / FH - DS / ...
ELAB / FH - DV / ...

2

Retrofit possible.

Sensor EASYLAB DS-TRD-01 for retrofit or as replacement part

DS - TRD - 01

Dimensions

Dimensional drawing of DS-TRD-01

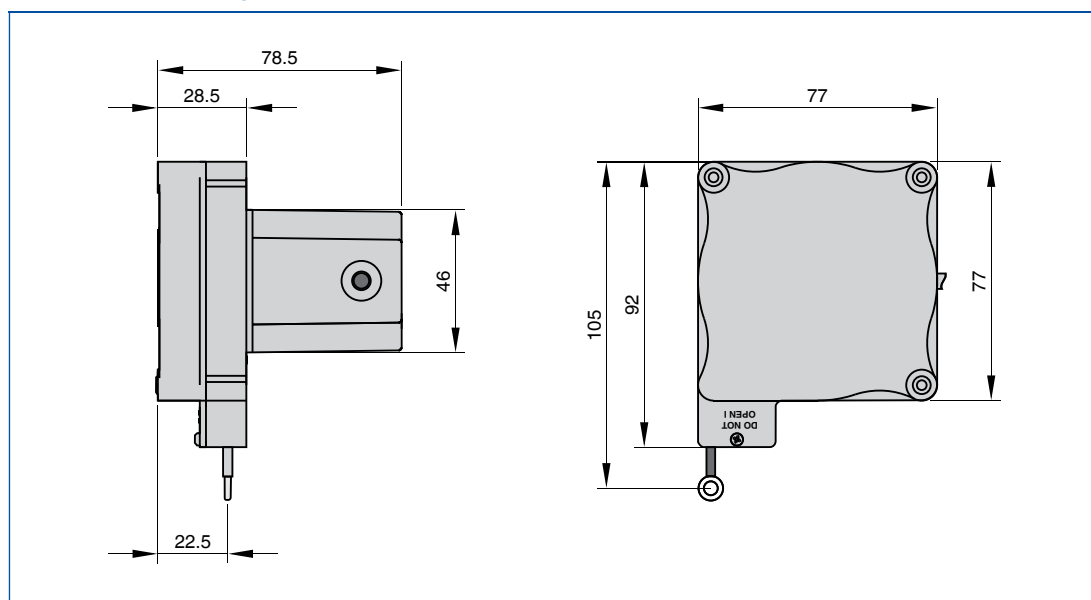

Dimensions

Dimensional drawing of DS-TRD-01

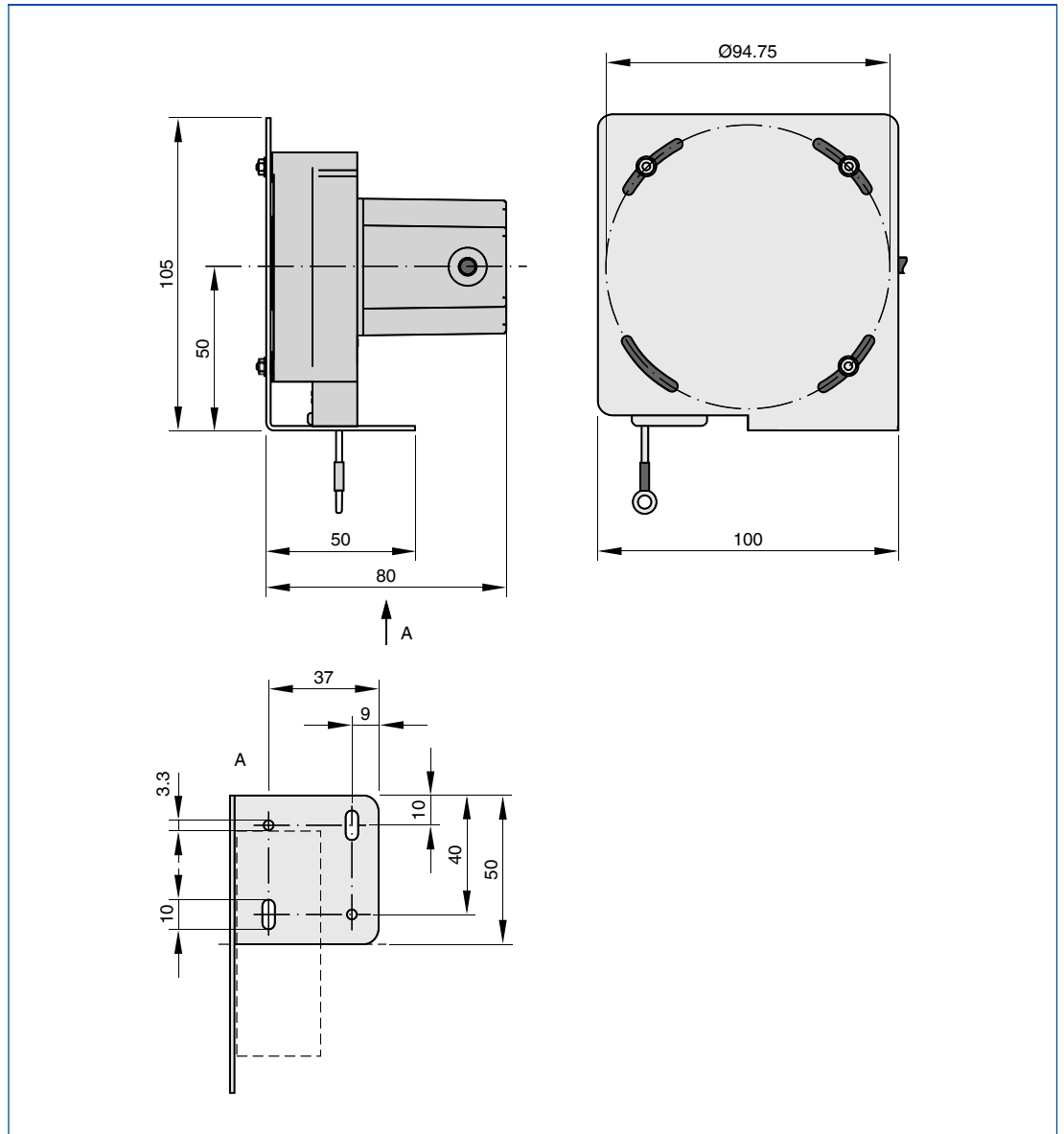

Installation and
commissioning

Measurement location of the sash distance
sensor (FH-DS, FH-DV)

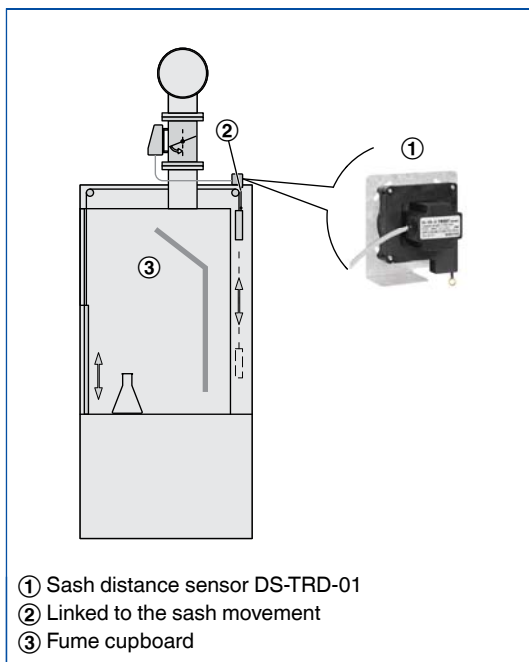

Measuring range of DS-TRD-01

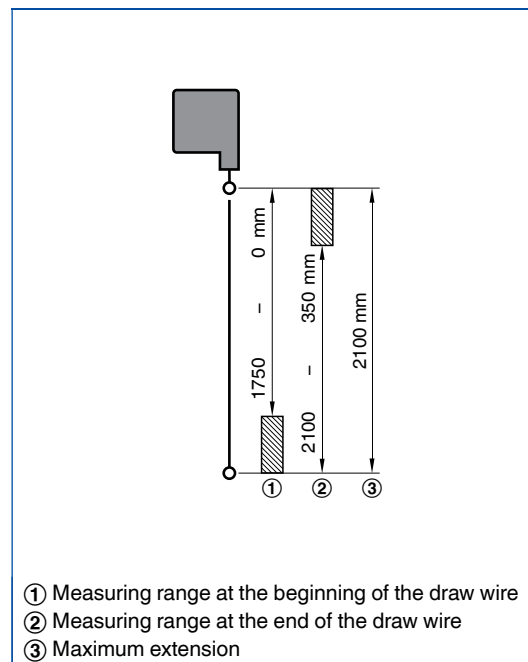

Specification text

Electronic sash distance sensor for the EASYLAB system, used to capture the sash distance of fume cupboards.

Suitable for sashes with 1750 mm maximum opening.

The sash distance is measured using a draw wire. A 0 – 10 V DC voltage signal that is proportional to the opening is emitted. If the sensor is connected to a fume cupboard controller, the volume flow is controlled based on demand.

Simple installation in several installation positions on the fume cupboard; simple linking to the sash movement.

Special features

- Suitable for sashes with 1750 mm maximum opening
- Suitable for EASYLAB controller TCU3
- Can be used with different control strategies (FH-DS and FH-DV)
- Ideal for rooms with high airflow velocities or levels of turbulence
- Replaces a separate contact for sash distance monitoring according to EN 14175

Materials and surface

- Plastic casing, black
- Measuring wire made of stainless steel, with a polyamide jacket
- Mounting bracket made of galvanised sheet steel

Technical data

- Supply voltage 12 V DC from the controller
- Measuring range: 0 – 1750 mm or 350 – 2100 mm
- Measurement accuracy: $\pm 0.25\%$ of the reading
- Output: Actual value signal: 0 – 10 V
- Protection level: IP 40

Standard text

Sensor systems

Type: Differential pressure transducers



For the differential pressure recording and control in combination with EASYLAB and TCU-LON-II

Differential pressure transducers based on the static measurement principle for the room or duct pressure control in combination with EASYLAB controllers TCU3 or LABCONTROL controllers TCU-LON-II

- Suitable for air and non-aggressive media
- For use in laboratories, clean rooms in the pharmaceutical and semiconductor industries, operation theatres, intensive care units, and offices with very demanding control requirements
- Construction variants with calibration certificate to meet GMP requirements

Type		Page
Differential pressure transducer	General information	2.4 – 14
	Order code	2.4 – 16
	Special information – DPS	2.4 – 17
	Special information – 699	2.4 – 18
	Special information – GB604	2.4 – 19
	Specification text	2.4 – 20
	Basic information and nomenclature	2.7 – 1

2 Variants

Product examples

Differential pressure transducer DPS



Differential pressure transducer 699



Differential pressure transducer GB 604 MF



Description

Application

- Differential pressure transducer for the LABCONTROL system
- For the room or duct pressure control in combination with EASYLAB controllers TCU3 or with TCU-LON-II
- For the room and duct pressure monitoring in combination with monitoring systems TPM

- For use in laboratories, clean rooms in the pharmaceutical and semiconductor industries, operation theatres, intensive care units, and offices with very demanding control requirements

Variants

- DPS50: Measuring range ± 50 Pa
- DPS100: Measuring range ± 100 Pa

- 699: Measuring range ± 50 or ± 100 Pa
- 699-LCD: Measuring range ± 50 or ± 100 Pa, with differential pressure display
- GB404: Measuring range ± 100 Pa
- GB604-CAL: Measuring range ± 100 Pa, with calibration certificate to meet GMP requirements (Good Manufacturing Practice)
- Choose a sufficient measuring range above/below the setpoint pressure

Installation and commissioning

- Choose a suitable installation location (reference room with stable pressure)
- Ensure sufficient cross section and careful placing of the measuring tubes
- Connect the differential pressure transducer to the controller or monitoring system
- Supply voltage from the EASYLAB TCU3 controller or TCU-LON II (supply voltage for the

- differential pressure transducer must be equal to the supply voltage provided by the controller)
- Consider the warm-up time of the sensor
- Do not install the sensor near sources of interference such as transformers, senders, motors, or heat sources
- Choose a stable installation location as shocks or vibration may distort the output signal
- Installation should be vertical, with connections pointing downwards; this installation position corresponds to the factory setup for calibration; it also prevents the ingress of condensate from the pressure tubes.
- Zero point correction required

Maintenance

- Zero point correction once per year is recommended

Function

Functional description

Static differential pressure transducers function according to the static differential pressure measurement principle. The sensor is a cylinder that consists of two chambers (one for positive pressure and one for negative pressure) separated by a diaphragm. If there is equal pressure in both chambers, the diaphragm is the

middle between the chambers and is not deformed. If there is a pressure difference, the diaphragm deforms towards the chamber with the negative pressure. The degree by which the diaphragm deforms is a measure for the differential pressure. This is why the voltage signal is proportional to the differential pressure.

Principle of operation – room pressure control

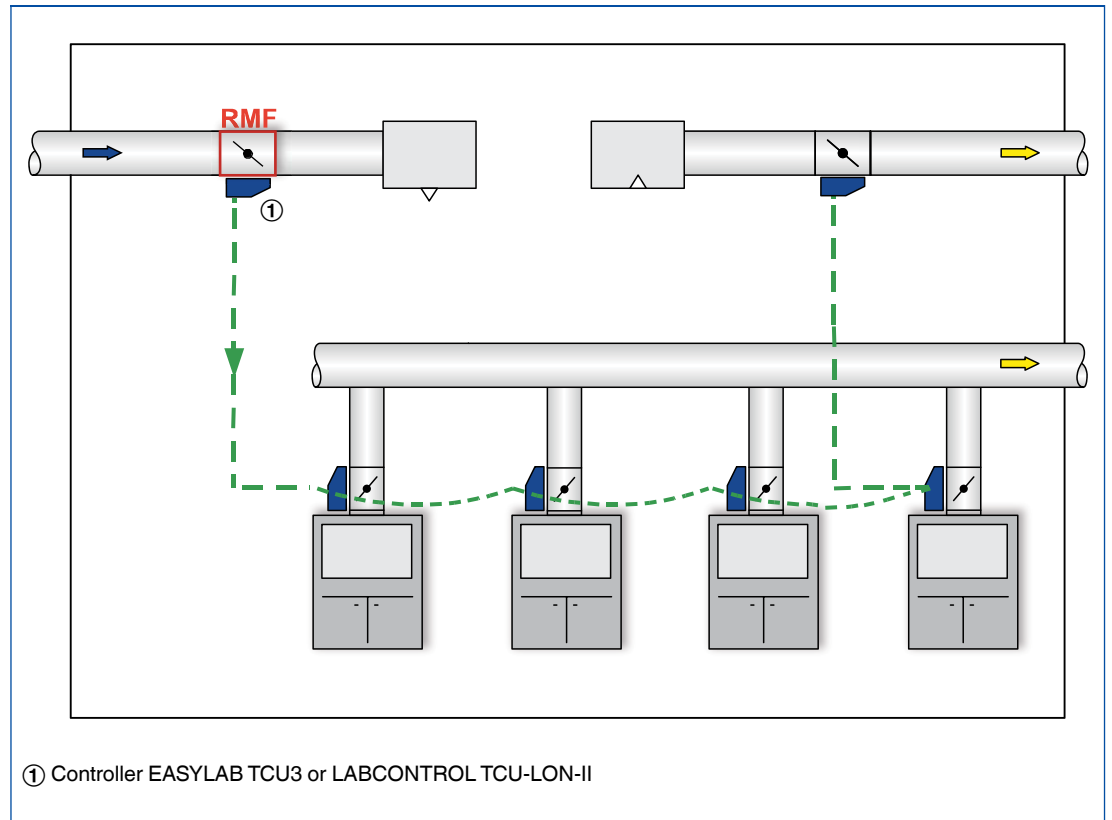

Order code

Differential pressure transducer

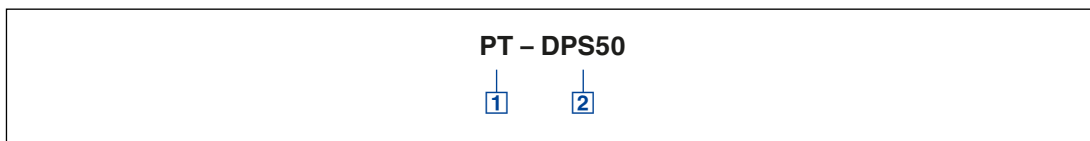

1 Type

PT Differential pressure transducer

2 Variants

DPS50 Measuring range ± 50 Pa

DPS100 Measuring range ± 100 Pa

699 Measuring range ± 50 or ± 100 Pa

699-LCD Measuring range ± 50 or ± 100 Pa, with differential pressure display

GB604 Measuring range ± 100 Pa

GB604-CAL Measuring range ± 100 Pa, with calibration certificate

Order example

PT-GB604-CAL

Measuring range ± 100 Pa, with calibration certificate

Description



Differential pressure transducer DPS

Application

- Differential pressure transducer for the LABCONTROL system
- For the room or duct pressure control in combination with EASYLAB controllers TCU3 or with TCU-LON-II
- For the room and duct pressure monitoring in combination with monitoring systems TPM

Variants

- DPS50: Measuring range ± 50 Pa
- DPS100: Measuring range ± 100 Pa

Parts and characteristics

- Robust casing made of ABS plastic
- Connections for tubes
- Inductive measuring system, hence not subject to wear
- Zero point potentiometer

Construction features

- Plastic casing with fixing points at the outside, can be mounted to the wall or ceiling
- Parts in contact with medium: Ni, Al, CuBe, PU

Materials and surface

- ABS plastic casing, black

Maintenance

- Zero point correction once per year is recommended

Technical data

Static differential pressure transducer DPS

Supply voltage	24 V AC ± 10 %
Power rating	1.8 VA
Output signal	0 – 10 V DC; 5 mA max.
Media	non-aggressive gases
Measuring range	± 50 Pa or ± 100 Pa
Measurement accuracy	± 1 % of full scale
Overload protection	up to 5-fold measuring range
Connections for tubes	$\varnothing 6.6 \times 11$ mm (for flexible tubes 6 mm)
Operating temperature	-10 to 50 °C
IEC protection class	III (Schutzkleinspannung)
Protection level	IP 54
EC conformity	EMC according to 2004/108/EG
Dimensions (B x H x T)	122 x 80 x 55 mm
Weight	0.3 kg

Electrical wiring

Terminal connections

○	○	○	○
1	2	3	4
⊥	~	-	+

DPS

1 ⊥: Neutral
2 ~: Supply voltage
3 -: Actual value signal, ground
4 +: Actual value signal

Description



Differential pressure transducer 699

Application

- Differential pressure transducer for the LABCONTROL system
- For the room or duct pressure control in combination with EASYLAB controllers TCU3 or with TCU-LON-II
- For the room and duct pressure monitoring in combination with monitoring systems TPM

Variants

- 699: Measuring range ± 50 or ± 100 Pa
- 699-LCD: Measuring range ± 50 or ± 100 Pa, with differential pressure display

Special features

- Supply voltage: A.C. or D.C. voltage (ideal for EASYLAB with EM-TRF-USV)
- Adjustable measuring ranges
- Short circuit proof and with reverse voltage protection

Parts and characteristics

- Plastic casing
- Connections for tubes
- Push button for zero point reset
- Adjustable measuring ranges
- 699-LCD: Differential pressure display

Construction features

- Fixing points at the outside, for mounting to a wall or ceiling

Materials and surface

- Transparent plastic casing

Maintenance

- Zero point correction once per year is recommended

Technical data

Static differential pressure transducer 699

Supply voltage	24 V AC $\pm 15\%$ or 13.5 – 33 V DC
Power rating	1 VA
Output signal	0 – 10 V DC, max. 1 mA
Media	non-aggressive gases
Measuring range	± 50 Pa factory set, can be changed to ± 100 Pa
Measurement accuracy	$\pm 2\%$ of full scale
Overload protection	for negative pressure measurement: -400 Pa at P1, for positive pressure measurement 10000 Pa at P1
Connections for tubes	$\varnothing 6.2$ mm (for flexible tubes 6 mm)
Operating temperature	0 – 70 °C (non-condensing)
IEC protection class	III (protective extra-low voltage)
Protection level	IP 54 (with cover)
EC conformity	EMC according to 2004/108/EG
Dimensions (B x H x T)	92 x 75 x 48 mm
Weight	0.1 kg

Electrical wiring

Terminal connections

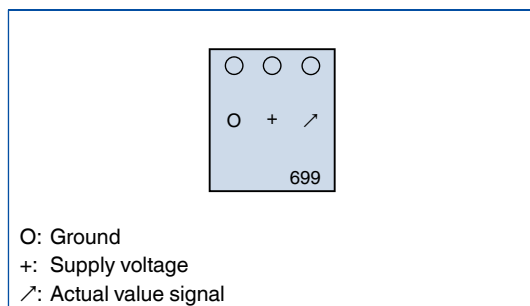

Description



Differential pressure transducer GB 604 MF

Application

- Differential pressure transducer for the LABCONTROL system
- For the room or duct pressure control in combination with EASYLAB controllers TCU3 or with TCU-LON-II
- For the room and duct pressure monitoring in combination with monitoring systems TPM

Variants

- GB404: Measuring range ± 100 Pa
- GB604-CAL: Measuring range ± 100 Pa, with calibration certificat to meet GMP requirements (Good Manufacturing Practice)

Special features

- Supply voltage: A.C. or D.C. voltage, switching between A.C. and D.C. is possible

Parts and characteristics

- Plastic casing
- Zero point potentiometer

Construction features

- Fixing points at the inside, for mounting to a wall or ceiling
- Capacitive stainless steel measuring cell

Materials and surface

- Plastic casing, light grey

Maintenance

- Zero point correction once per year is recommended

Technical data

Static differential pressure transducer GB604

Supply voltage	24 V AC, 24 V DC ± 10 % (switching is possible)
Power rating	1.8 VA
Output signal	0 – 10 V DC; 2 mA max.
Media	non-aggressive gases
Measuring range	± 100 Pa
Measurement accuracy	± 0.5 % of full scale
Maximum operating pressure	70 kPa
Connections for tubes	for flexible tubes 4 mm
Operating temperature	-20 to 65 °C
IEC protection class	III (protective extra-low voltage)
Protection level	IP 54
EC conformity	EMC according to 2004/108/EG
Dimensions (B x H x T)	122 x 120 x 58 mm
Weight	0.3 kg

Electrical wiring

Terminal connections

○	○	○	○
1	2	3	4
+	-	+	-
~	⊥		
GB604			

1 ~, +: Supply voltage
 2 ⊥, -: Ground, neutral
 3 +: Actual value signal
 4 -: Actual value signal, ground

Standard text

This specification text describes just one variant of the product that applies to many applications. Texts for other variants can be generated with our Easy Product Finder design programme.

Differential pressure transducer for the LABCONTROL system, for the measurement of room or duct pressure.

When the transducer is connected to a room controller, the supply air or extract air flow is controlled based on the differential pressure.

2

Order options

1 Type

PT Differential pressure transducer

2 Variants

- DPS50** Measuring range ± 50 Pa
- DPS100** Measuring range ± 100 Pa
- 699** Measuring range ± 50 or ± 100 Pa
- 699-LCD** Measuring range ± 50 or ± 100 Pa, with differential pressure display
- GB604** Measuring range ± 100 Pa
- GB604-CAL** Measuring range ± 100 Pa, with calibration certificate

Control panels

Type BE-LCD-01



Display, function buttons with status display

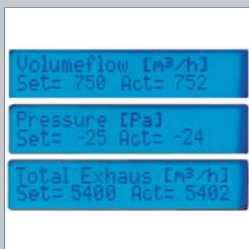

Text display



Control panel

For EASYLAB fume cupboard controllers or room controllers, with text display

Control panels to be used with fume cupboard controllers or room controllers, for displaying operating values, activating functions and signalling operating states

- Signalling of safety-related functions for fume cupboards according to EN 14175 or of operating states for rooms
- Display of actual values, setpoint values, and status messages
- Wireless communication with Bluetooth module
- 40-character text display
- Push buttons for the operating mode default setting and for specific functions
- Project-specific range of functions with configurable push buttons
- Integral service socket for configuration and diagnosis
- Casing suitable for flush mounting to fume cupboard side frame, or for surface mounting on a wall

Type		Page
BE-LCD-01	General information	2.5 – 2
	Fume cupboard control	2.5 – 4
	Room control	2.5 – 5
	Installation and commissioning	2.5 – 6
	Specification text	2.5 – 8
	Basic information and nomenclature	2.7 – 1

Description



Control panel Type BE-LCD-01

Application

- Control panels Type BE-LCD-01 for displaying and operating the aerodynamic functions of fume cupboards or rooms
- Display of actual values, setpoint values, and operating states either as text or on the status display
- Optical and acoustic alarms
- Operating mode default setting
- Operation of lighting, automatic sash device or blinds without additional installation or wiring

Control panel for fume cupboard control

- Status display to EN 14175
- Connection to fume cupboard controller EASYLAB TCU3

Room control panel

- Status display for the volume flow rate or differential pressure control of a room
- Connection to room controller EASYLAB TCU3 or TAM with active room management function

Useful additions

- EasyConnect: Configuration software for the commissioning and diagnosis of EASYLAB components

Special features

- Large three-colour status display
- Push buttons and functions can be configured individually
- Easy to use – available function buttons are visible, unavailable function buttons are not visible
- Excellent operating reliability as a result of continuous self-monitoring of the communication between controller and control panel
- Pluggable adapter which can provide four different viewing angles
- Mounting on side frame or wall

Parts and characteristics

- 40-character display, backlit (blue)
- Three-colour status display (green, yellow, red) with text HIGH and LOW
- Sash monitoring warning display
- 8 function button fields, can be individually activated
- Alarm sounder
- Connection socket for EASYLAB controller
- Integral service socket for configuration and diagnosis of the controller
- Wireless communication with Bluetooth module BlueCon
- 5 m connecting cable
- Rectangular casing suitable for flush mounting or surface mounting

Construction features

- Casing with base plate and pluggable adapter to facilitate mounting
- Adapter allows for mounting even on small side frames of fume cupboards
- Pluggable adapter which can provide four different viewing angles: from the right, from the left, from top, from bottom
- Pluggable connections

Materials and surface

- Casing in ABS plastic
- Casing: pearl light grey (RAL 9022)
- Front plastic: anthracite grey (RAL 7016)

Installation and commissioning

- Mounting on the fume cupboard, using the adapter: right-hand side frame, left-hand side frame, above the sash, or below the sash
- Mounting on walls or furniture, also directly on junction boxes
- Connect the control panel to the EASYLAB controller TCU3 or to TAM
- Controller recognises the control panel
- If necessary, make project-specific adjustments using the EasyConnect configuration software

Technical data

Supply voltage	24 V DC from the controller TCU3 or adapter module TAM
Connecting cable	Approx. 5 m standard network patch cable, SF-UTP, extendable to 40 m
Operating temperature	10 – 50 °C
IEC protection class	III (protective extra-low voltage)
Protection level	IP 20
EC conformity	EMC according to 2004/108/EG
Dimensions	145 × 111 × 23 mm
Weight	0.28 kg

The BE-LCD-01 control panel is used to display and control the most critical aerodynamic and safety-related functions of a fume cupboard or a room. Users obtain information regarding the condition of the fume cupboard or room and can select among various operating modes. The individual display elements and controls are as follows:

- Three-colour status display
- Warning display
- 40-character display
- Alarm sounder
- 8 function button fields: 1 acoustic alarm acknowledgement, 3 operating mode buttons, 2 buttons for the automatic sash device, 1 button for the fume cupboard lighting, 1 button for manual control
- Service socket

The range of functions of the control panel can be adapted to project-specific requirements using the EasyConnect configuration software. The range of functions may vary for different fume cupboards. The function button fields are used for display and as buttons for operation. The available functions are highlighted (blue).

The required function can be selected by pressing the appropriate button.

- Selecting an operating mode
- Automatic sash device
- Fume cupboard lighting on/off

The 40-character display shows system messages or, if enabled, actual values.

EASYPAN control panel BE-LCD-01

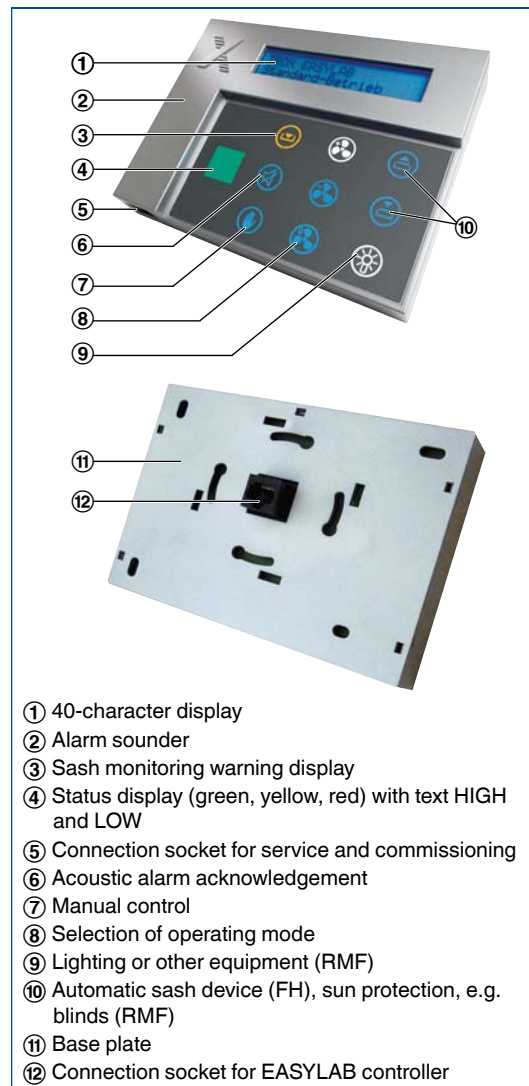

- ① 40-character display
- ② Alarm sounder
- ③ Sash monitoring warning display
- ④ Status display (green, yellow, red) with text HIGH and LOW
- ⑤ Connection socket for service and commissioning
- ⑥ Acoustic alarm acknowledgement
- ⑦ Manual control
- ⑧ Selection of operating mode
- ⑨ Lighting or other equipment (RMF)
- ⑩ Automatic sash device (FH), sun protection, e.g. blinds (RMF)
- ⑪ Base plate
- ⑫ Connection socket for EASYPAN controller

Order code

BE-LCD-01

<p>BE - LCD - 01</p> <p>1</p>

1 Type

BE-LCD-01 Control panel with 40-character display

Description

Application

- Displaying and operating the aerodynamic functions of fume cupboards
- Status display to EN 14175
- Connection to fume cupboard controller EASYLAB TCU3
- Two control panels can be used for each fume cupboard controller, e.g. for fume cupboards with sash windows on two sides

Functions

- Signalling of safety-related functions for fume cupboards according to EN 14175
- Sash distance monitoring

Text displays

- Volume flow rate actual value and setpoint value
- Face velocity actual value (fume cupboards with face velocity transducer, equipment function FH-VS)
- Divesity threshold has been exceeded

- Service is due
- Power supply failure (EASYLAB controller with expansion module EM-TRF-USV)
- Smoke extract function
- Extract air scrubber is active

Configurable functions

- Operating modes
- Lighting
- Automatic sash device

Operating modes

- Increased volume flow (emergency operation)
- Reduced volume flow (night-time operation)
- Shut-off (night-time operation, system shutdown)
- Manual mode (permanent override of central settings)
- Increased volume flow and manual mode can be set for a limited period

Function

The fume cupboard controller monitors the required volume flow rate and, depending on configuration, the face velocity. A relevant deviation is indicated on the three-colour status display, together with the text LOW or HIGH. If the volume flow rate is too low, an acoustic alarm is sounded.

Status display

- Green: Normal operation
- Red with text LOW: Alarm, volume flow rate too low
- Yellow with text HIGH: Warning, volume flow rate too high

The red signal can be configured either as a permanent light or blinking, as recommended by EN 14175

40-character display

- Text display of operating values, system states and faults in various languages
- Information about the safety of the user's work place

Controls

- Function buttons to switch operating modes, automatic sash device or fume cupboard lighting

Operation

BE-LCD-01 as control panel for fume cupboards, typical configuration and display example

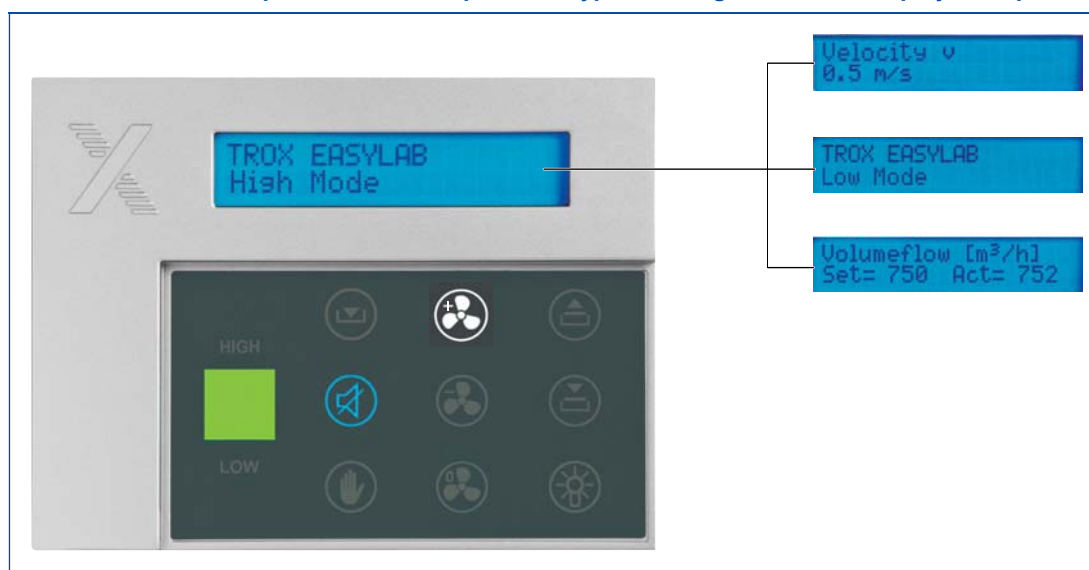

Description

Application

- Displaying and operating the aerodynamic functions for rooms with up to 24 EASYLAB controllers TCU3
- Connection to room controller EASYLAB TCU3 or TAM with active room management function
- The room control panel is the main unit for the room operating mode concept within the EASYLAB system
- Two room control panels can be used for each room controller, e.g. on the two doors to a large laboratory

Functions

- State signalling for the configured room functions

Monitoring

- Minimum total room extract air (shortfall will be signalled)
- Total room extract air (excess will be signalled)
- Room or duct pressure control
- Configurable consolidated alarm (volume flow rate deviations, device faults) for all controllers in a room

Text displays

- Room operating mode
- Total room extract air setpoint value and actual value (can be configured)
- Room pressure setpoint value and actual value (can be configured)
- System and device faults
- Power supply failure (EASYLAB controller with expansion module EM-TRF-USV)
- Diversity threshold has been exceeded or diversity control is active (option)

Configurable functions

- Selection of operating mode for all controllers in a room, without additional wiring
- Increased volume flow (emergency operation)
- Reduced volume flow (night-time operation)
- Shut-off (night-time operation, system shutdown)
- Manual mode (permanent override of central settings)
- Control input signal for an individually usable relay changeover contact, e.g. for lighting
- Control input signal for sun protection/blinds (to be provided by others)
- Increased volume flow and manual mode can be set for a limited period

Function

Depending on the control strategy and configuration, the control panel monitors and signals for example the total volume flow rates or pressure conditions for a room that is equipped with up to 24 EASYLAB controllers. Relevant deviations are indicated on the three-colour status display. As an option, acoustic alarms can be configured.

Controller faults are signalled to the room control panel as an configurable consolidated alarm. The necessary data is exchanged between the controllers via the EASYLAB communication cable.

Operation

BE-LCD-01 as room control panel, typical configuration and display example

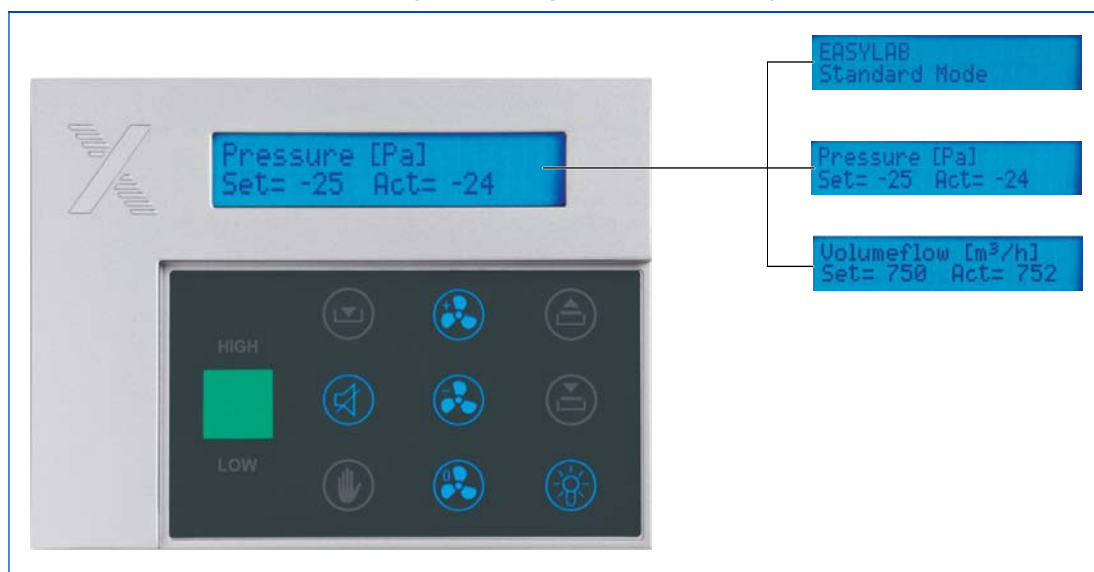

Mounting the controller onto a fume cupboard

On the left-hand side frame



On the right-hand side frame



Above the sash

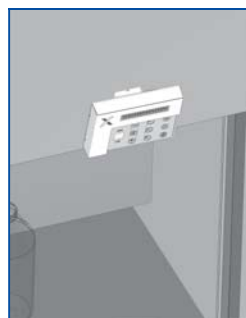

Below the sash

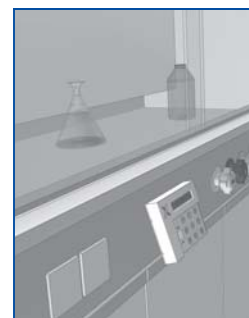

Dimensional drawing of BE-LCD-01, mounted on a fume cupboard

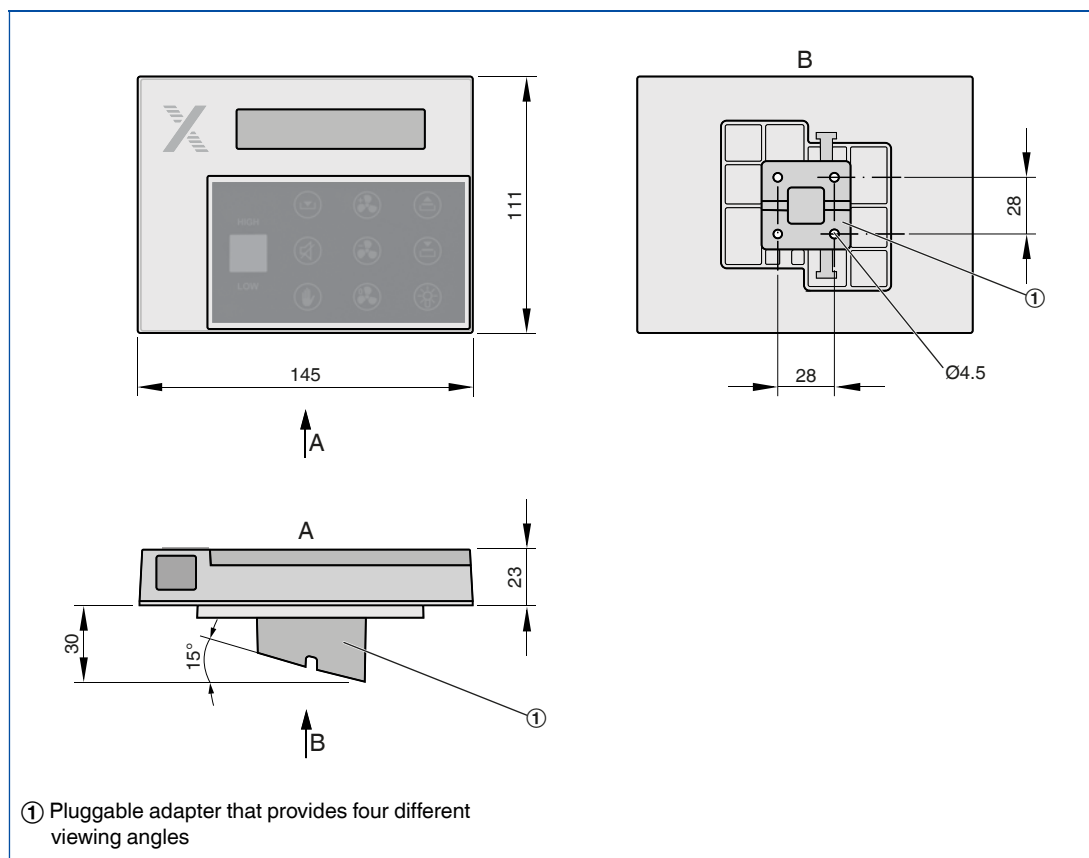

Installing the controller on a wall

Fixing the base plate to a junction box

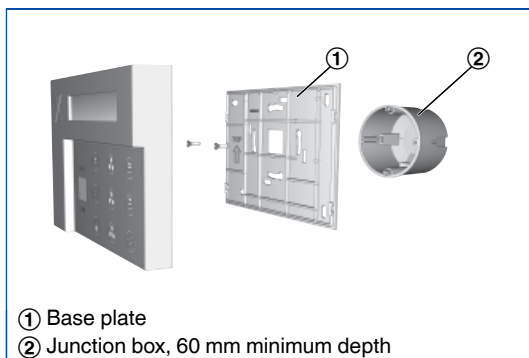

Fixing the base plate to the wall

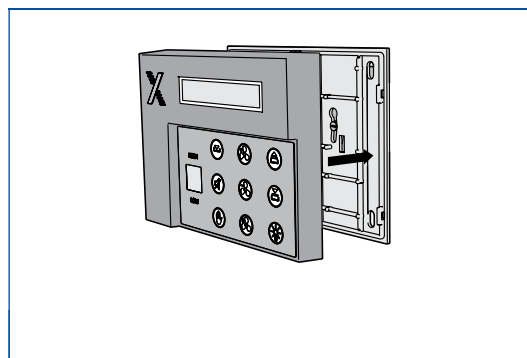

Dimensional drawing of BE-LCD-01, wall mounting without adapter

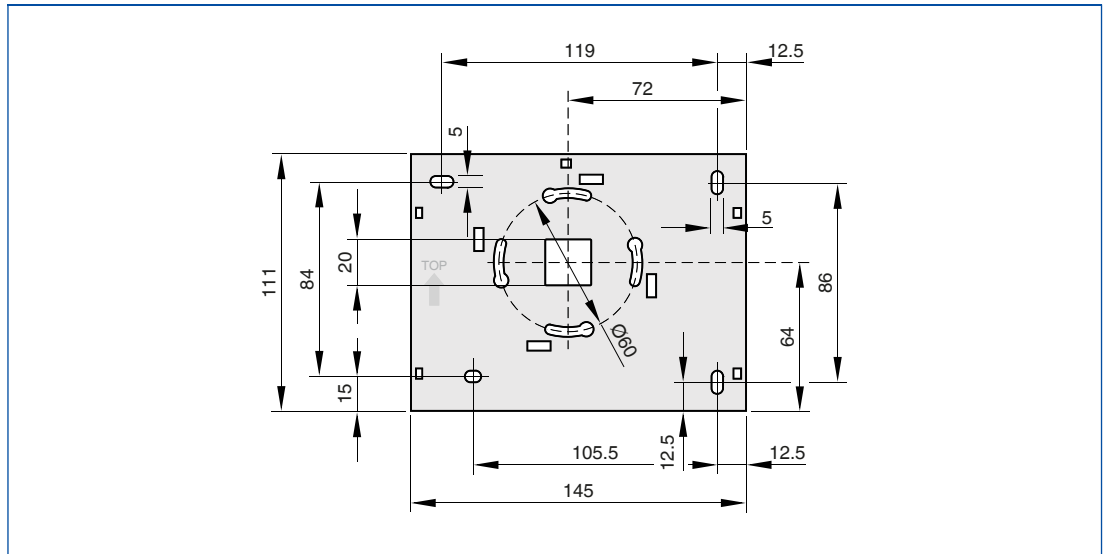

Commissioning

Connection of commissioning and service devices with a cable

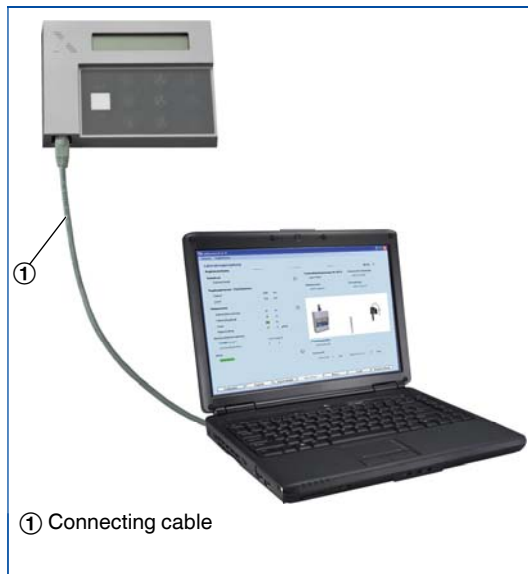

Wireless connection of commissioning and service devices

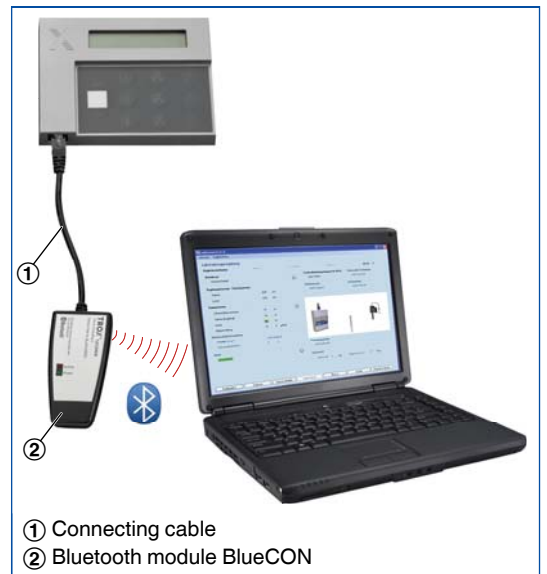

Standard text

Control panels with adjustable status display for the EASYLAB system, used to display and control the most critical aerodynamic and safety-related functions of a fume cupboard or a room. The control panel includes a backlit 40-character display, function buttons, a three-colour status display, an alarm sounder, and a service socket. Mounting on side frame or wall

Scope of functions

- Configurable, optical and acoustic signalling of the safety-related functions
- Text displays in several languages
- Large three-colour status display; green, yellow or red with text LOW or HIGH (red: either blinking or permanent)
- Continuous self monitoring of the communication between controller and control panel
- Integral service socket for configuration and diagnosis
- Wireless communication with Bluetooth module BlueCon
- Two control panels can be connected simultaneously to a controller

Configurable functions

- Available (configured) function buttons are visible
- Unavailable function buttons are not visible

Control panel for fume cupboard controller

Function buttons that can be activated

- Warning display 'maximum operational sash opening' has been exceeded
- Increased volume flow
- Reduced volume flow
- Shut-off mode
- Automatic sash device
- Fume cupboard lighting
- Manual mode (override operating mode default setting)

Text display

- Service is due (option)
- Power supply failure (EASYLAB controller with expansion module EM-TRF-USV)
- Smoke extract is active
- Extract air scrubber is active
- Device faults (various codes)
- Display of face velocity actual value at fume cupboards (option for fume cupboards with face velocity transducer)

Control panel for room controllers

Scope of functions

- Configurable, optical and acoustic signalling of the safety-related functions of a room with up to 24 EASYLAB controllers
- Room pressure monitoring
- Monitoring of the total room extract air (excess will be signalled)
- Monitoring of the minimum room extract air (shortfall will be signalled)
- Consolidated alarm for the room

Function buttons that can be activated

- Increased volume flow
- Reduced volume flow
- Shut-off mode
- Manual mode (override room operating mode default setting)
- Control input signal for an individually usable relay changeover contact, e.g. for lighting
- Control input signal for sun protection/blinds (to be provided by others)

The operating mode default setting applies to all controllers in a room.

Text display

- Room operating mode
- Total room extract air setpoint value and actual value (option)
- Room pressure setpoint value and actual value (option)
- System and device faults
- Power supply failure (EASYLAB controller with expansion module EM-TRF-USV)

Special features

- Large three-colour status display
- Push buttons and functions can be configured individually
- Easy to use – available function buttons are visible, unavailable function buttons are not visible
- Excellent operating reliability as a result of continuous self-monitoring of the communication between controller and control panel
- Pluggable adapter which can provide four different viewing angles
- Mounting on side frame or wall

Materials and surface

- Casing in ABS plastic
- Casing: pearl light grey (RAL 9022)
- Front plastic: anthracite grey (RAL 7016)

Technical data

- Supply voltage: 24 V DC from the controller TCU3 or adapter module TAM
- Plug-in connection cable, 5 m long, extendable to 40 m (standard network patch cable SF-UTP)
- Protection level: IP 20

Control panels

Type BE-SEG



For EASYLAB fume cupboard controllers

Control panels to be used with fume cupboard controllers, for displaying operating values, activating functions and signalling operating states

- Signalling of safety-related functions of fume cupboards according to EN 14175
- Display of actual values, setpoint values, and status messages
- Two-character display for displaying system information and face velocity
- Wireless communication with Bluetooth module
- Push buttons for the operating mode default setting and for specific functions
- Project-specific range of functions with configurable push buttons
- Two control panels can be used simultaneously for each fume cupboard controller
- Integral service socket for configuration and diagnosis
- Casing suitable for flush mounting or surface mounting to the fume cupboard side frame

Optional equipment and accessories

- Indication of power supply failure for fume cupboard controllers with expansion module EM-TRF-USV

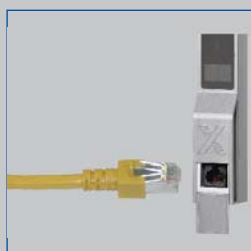

Connection socket for controller configuration



Control panel integrated into the side frame

Type		Page
BE-SEG	General information	2.5 – 10
	Installation and commissioning	2.5 – 14
	Specification text	2.5 – 16
	Basic information and nomenclature	2.7 – 1

2 Variants

Product examples

**Control panel Type
BE-SEG-01**



**Control panel Type
BE-SEG-21**



Description

Application

- Control panels Type BE-SEG for displaying and operating the aerodynamic functions of fume cupboards
- Status display to EN 14175
- Display of actual values, setpoint values, and operating states
- Optical and acoustic alarms
- Operating mode default setting
- Operation of lighting or automatic sash device without additional installation or wiring
- Connection to fume cupboard controller EASYLAB TCU3

Variants

- BE-SEG-01: Control panel for all fume cupboards
- BE-SEG-21: Control panel optimised for Type SCALA fume cupboards by WALDNER

Useful additions

- EasyConnect: Configuration software for the commissioning and diagnosis of EASYLAB components

Special features

- Optical and acoustic signalling of the safety-related functions of the fume cupboard according to EN 14175
- Large three-colour status display
- Push buttons and functions can be configured individually
- Easy to use – available function buttons are visible, unavailable function buttons are not visible
- Excellent operating reliability as a result of continuous self-monitoring of the communication between controller and control panel
- Two control panels can be used for each fume cupboard controller, e.g. for fume cupboards with sash windows on two sides

Parts and characteristics

- 2-character display
- Three-colour status display (green, yellow, red) with text HIGH and LOW
- Sash monitoring warning display
- 8 function button fields, can be individually activated
- Alarm sounder
- Connection socket for EASYLAB controller
- Integral service socket for configuration and diagnosis of the controller
- Wireless communication with Bluetooth module BlueCon
- 5 m connecting cable
- Rectangular casing suitable for flush mounting or surface mounting

Construction features

- Oblong display suitable for flush mounting or surface mounting to the fume cupboard side frame
- Surface mounting by screw fixing the casing to the side frame
- Flush mounting by clip fixing the display to the side frame (without casing)

Materials and surface

- Casing in ABS plastic
- Casing: pearl light grey (RAL 9022)
- Front plastic: anthracite grey (RAL 7016)

Installation and commissioning

- Surface mounting, with casing, to the side frame
- Flush mounting, without casing, to the side frame
- BE-SEG-21: Flush mounting to the side frame of the Type SCALA fume cupboard by WALDNER
- Connect the control panel to the EASYLAB controller TCU3
- Controller recognises the control panel
- If necessary, make project-specific adjustments using the EasyConnect configuration software

Technical data

Supply voltage	24 V DC from the controller TCU 3
Connecting cable	Approx. 5 m standard network patch cable, SF-UTP, extendable to 40 m
Operating temperature	0 – 50 °C
IEC protection class	III (protective extra-low voltage)
Protection level	IP 41 for surface mounting, IP 42 for flush mounting
Dimensions	29 × 310 × 30 mm
EC conformity	EMC according to 2004/108/EG
Weight	0.13 kg

Function

The control panel type BE-SEG-01 is used to display and control the most critical aerodynamic and safety-related functions of a fume cupboard. Users obtain information regarding the condition of the fume cupboard and can control various operating modes. The individual display elements and controls are as follows:

- Three-colour status display
- Warning display
- 2-character display
- Alarm sounder
- 8 function button fields: 1 acoustic alarm acknowledgement, 3 operating mode buttons, 2 buttons for the automatic sash device, 1 button for the fume cupboard lighting, 1 button for manual control
- Service socket

The range of functions of the control panel can be adapted to project-specific requirements using the EasyConnect configuration software. The range of functions may vary for different fume cupboards. The function button fields are used for display and as buttons for operation. The available functions are highlighted (blue).

The required function can be selected by pressing the appropriate button.

- Selecting an operating mode
- Automatic sash device
- Fume cupboard lighting on/off

The two-digit display shows system messages or, if enabled, the actual face velocity.

EASYLAB control panel BE-SEG-01, display and control elements

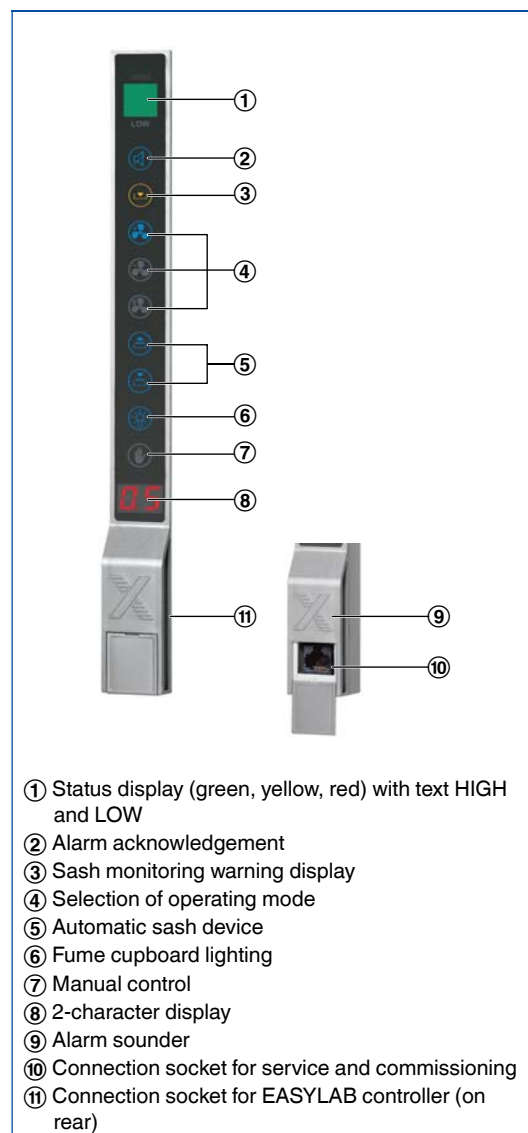

Order code

BE-SEG

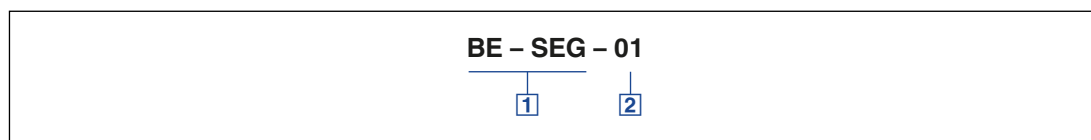

1 Type

BE-SEG Control panel with 2-character display for EASYLAB controllers TCU3

2 Variant

- 01** For all fume cupboards
- 21** For Type SCALA fume cupboards by WALDNER

Operation

BE-SEG-01, typical configuration and display example

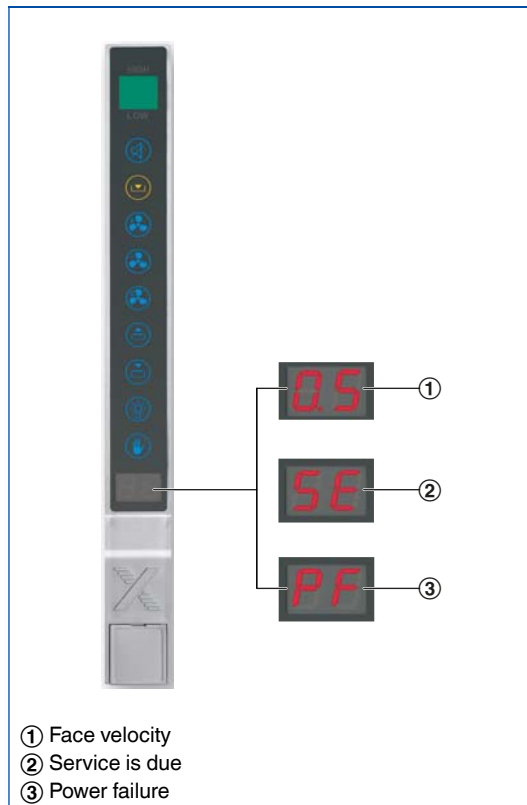

Installation

Dimensional drawing of BE-SEG-01, surface mounting

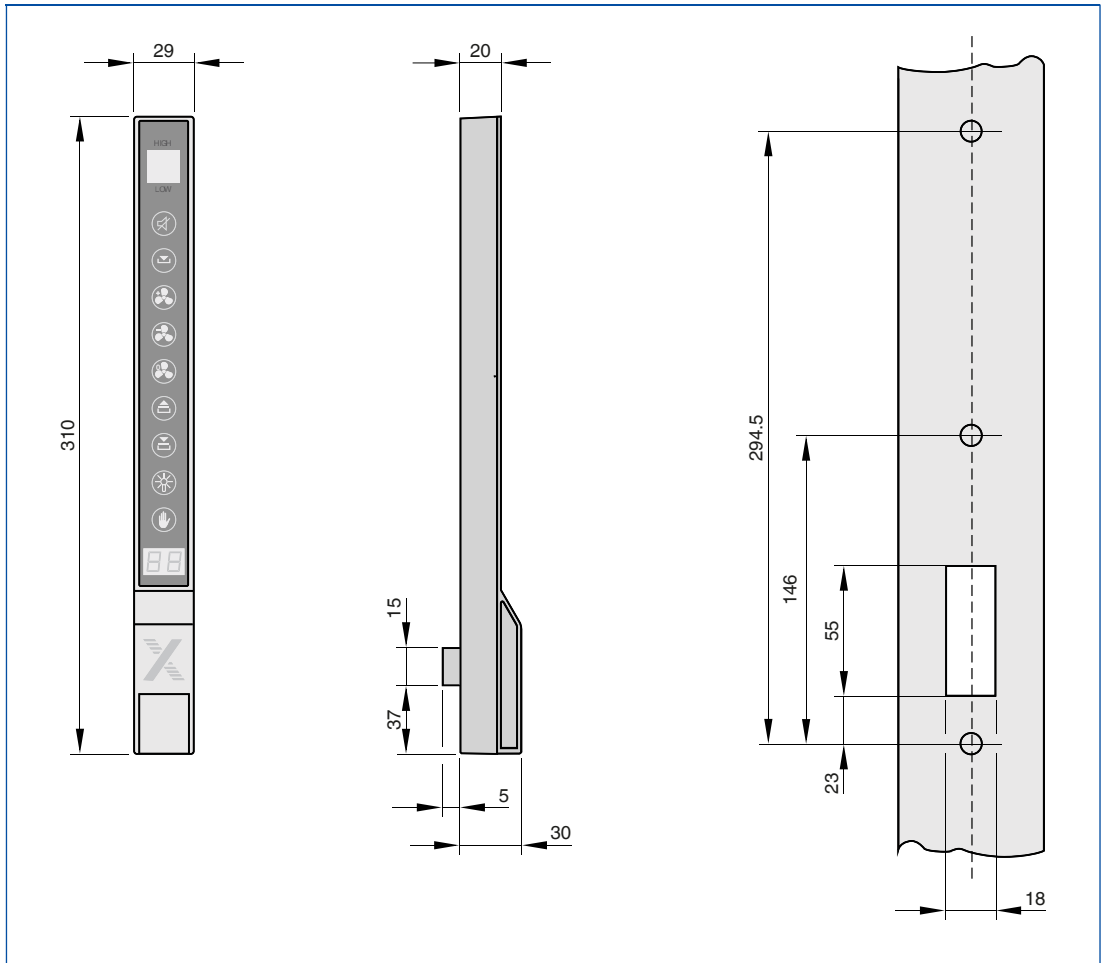

2

Installation

Dimensional drawing of BE-SEG-01, flush mounting

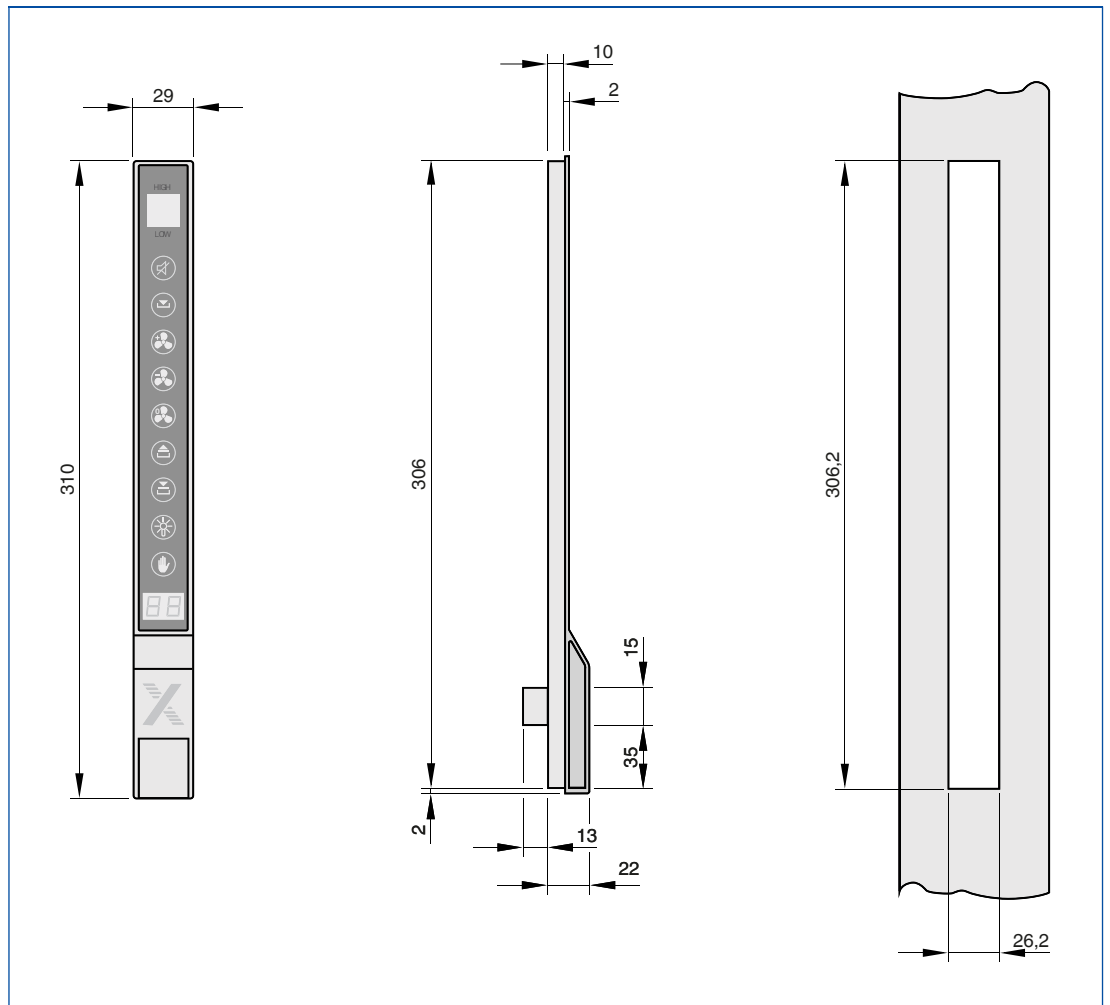

Commissioning

Connection of commissioning and service devices with a cable

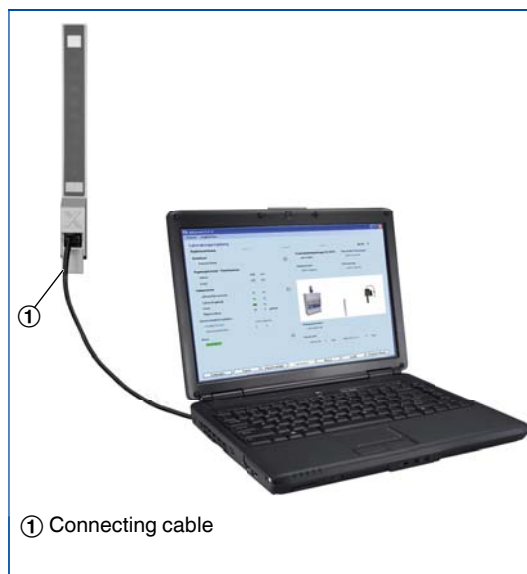

Wireless connection of commissioning and service devices

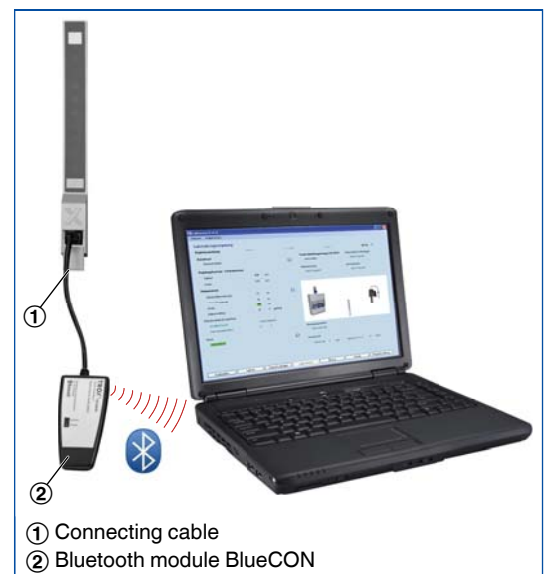

Standard text

Control panels with adjustable status display for the EASYLAB system, used to display and control the most critical aerodynamic and safety-related functions of a fume cupboard. The control panel includes a 2-character display, function buttons, a three-colour status display, an alarm sounder, and a service socket.

Casing suitable for flush mounting or surface mounting to the fume cupboard side frame

Scope of functions

- Configurable, optical and acoustic signalling of the safety-related functions
- Large three-colour status display; green, yellow or red with text LOW or HIGH (red: either blinking or permanent)
- Continuous self monitoring of the communication between controller and control panel
- Integral service socket for configuration and diagnosis
- Wireless communication with Bluetooth module BlueCon
- Two control panels can be connected simultaneously to a controller

Configurable functions

- Available (configured) function buttons are visible
- Unavailable function buttons are not visible

Function buttons that can be activated

- Warning display 'maximum operational sash opening' has been exceeded
- Increased volume flow
- Reduced volume flow
- Shut-off mode
- Automatic sash device
- Fume cupboard lighting
- Manual mode (override operating mode default setting)

Special features

- Optical and acoustic signalling of the safety-related functions of the fume cupboard according to EN 14175
- Large three-colour status display
- Push buttons and functions can be configured individually
- Easy to use – available function buttons are visible, unavailable function buttons are not visible
- Excellent operating reliability as a result of continuous self-monitoring of the communication between controller and control panel
- Two control panels can be used for each fume cupboard controller, e.g. for fume cupboards with sash windows on two sides

Materials and surface

- Casing in ABS plastic
- Casing: pearl light grey (RAL 9022)
- Front plastic: anthracite grey (RAL 7016)

Order options

1 Type

BE-SEG Control panel with 2-character display for EASYLAB controllers TCU3

2 Variant

- 01** For all fume cupboards
- 21** For Type SCALA fume cupboards by WALDNER

Control panels

Type BE-TCU-LON-II



2

For fume cupboard controllers TCU-LON-II

Control panels to be used with fume cupboard controllers, for activating functions and signalling operating states

- Signalling of safety-related functions of fume cupboards according to EN 14175
- Indicator lights for alarm and operating mode \dot{V}_{\max} (increased operation)
- Alarm sounder
- Indication of power supply failure for the fume cupboard controller
- Function buttons for alarm acknowledgement and operating mode \dot{V}_{\max} (increased operation)
- LON bus service socket
- LON commissioning button
- Casing suitable for flush mounting and for surface mounting

Type		Page
BE-TCU-LON-II	General information	2.5 – 18
	Specification text	2.5 – 20
	Basic information and nomenclature	2.7 – 1

Description



BE-TCU-LON-II

Application

- Control panels Type BE-TCU-LON-II for displaying and operating the aerodynamic functions of fume cupboards
- Status display to EN 14175
- Display of operating states
- Optical and acoustic alarms
- Operating mode default setting
- Connection to fume cupboard controller EASYLAB TCU-LON-II

Useful additions

- TCU-LON-II plug-in: Configuration software for the commissioning and diagnosis of TCU-LON-II

Special features

- Optical and acoustic signalling of the safety-related functions of the fume cupboard according to EN 14175
- Four indicator lights
- Function buttons for operating mode \dot{V}_{max} (increased mode), alarm acknowledgement, and LonWorks commissioning
- LON bus service socket
- Power failure indication

Parts and characteristics

- Detachable two-part casing
- Alarm indicator light (red)
- Normal operation indicator light (green)
- Acoustic alarm acknowledgement button
- Button for operating mode \dot{V}_{max} , with indicator light (yellow)
- ID run button (service pin LON-ID) for system integration
- Service connection for the LonWorks network
- Indication of power failure (red) by maintenance-free capacitor buffer, indication for up to 12 h
- 4 m connecting cable

Construction features

- Oblong display suitable for flush mounting or surface mounting to the fume cupboard side frame
- Surface mounting by screw fixing the casing to the side frame
- Flush mounting by clip fixing the display to the side frame (without casing)

Materials and surface

- Plastic casing

Installation and commissioning

- Surface mounting, with casing, to the side frame
- Flush mounting, without casing, to the side frame
- Connect the control panel to the TCU-LON-II controller

Technical data

Supply voltage	5 V DC from the controller
Connecting cable	4 m, with RJ45 plug connector, to connect the control panel to the controller
Operating temperature	0 – 50 °C
IEC protection class	III (protective extra-low voltage)
Protection level	IP 31 for surface mounting, IP 32 for flush mounting
EC conformity	EMC according to 2004/108/EG
Dimensions (B × H × T)	23 × 150 × 19 mm for surface mounting, 23 × 150 × 2.5 mm for flush mounting, installation depth 15 mm
Weight	0.1 kg

Function

The BE-TCU-LON-II control panel is used to display and control the most critical aerodynamic and safety-related functions of a fume cupboard. Users obtain information regarding the condition of the fume cupboard and can set operating mode \dot{V}_{max} .

Signalling

- Green: Normal operation
- Red with acoustic alarm: Volume flow rate or face velocity too low
- Red and green blinking: Night-time reduction or shut-off
- Yellow: Operating mode \dot{V}_{max}

- Yellow, blinking: Sash is open and should be closed (only with motion detector)
- Red: Power failure

Controls

- Alarm Quit: Acoustic alarm acknowledgement
- \dot{V}_{max} : Operating mode \dot{V}_{max} (increased volume flow)
- ID-Run: To send the neuron ID for system integration

The duration of the acoustic alarm and of operating mode \dot{V}_{max} can be configured.

Control panel BE-TCU-LON-II

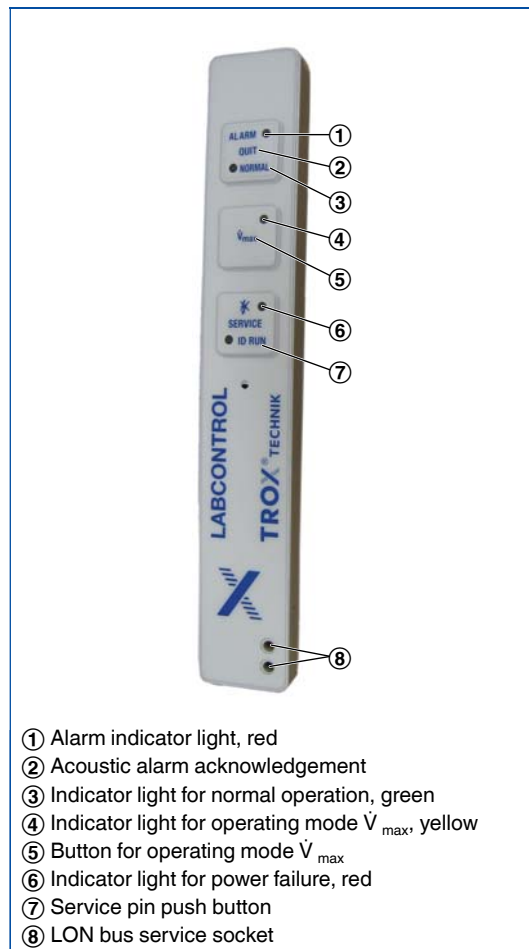

Dimensional drawing of BE-TCU-LON-II

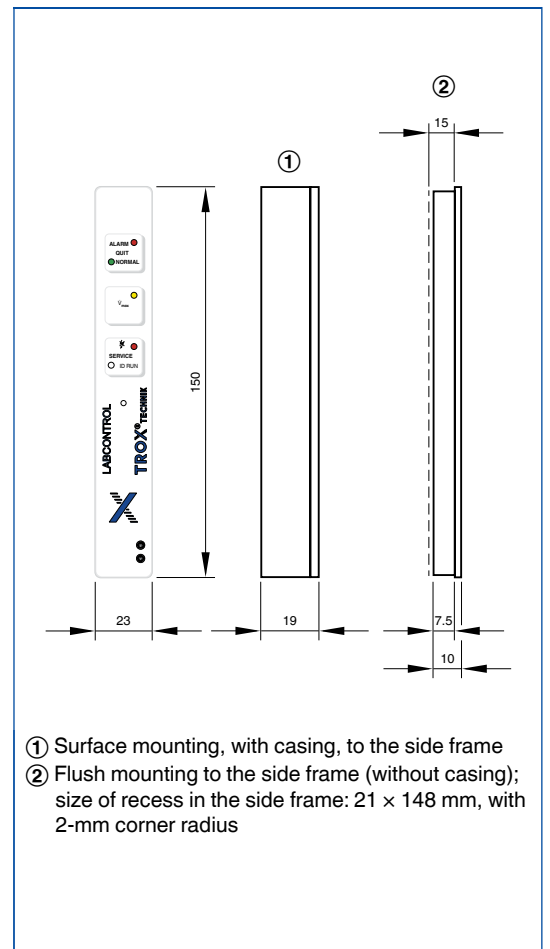

Order code

BE-TCU-LON-II

<p>BE - TCU-LON-II</p> <p>1</p>
--

1 Type

BE-TCU-LON-II Control panel for controller TCU-LON-II

Standard text

Fume cupboard control panels with status indication for the TCU-LON-II system, used to display and control the most critical aerodynamic and safety-related functions of a fume cupboard. The control panel includes function buttons, an alarm sounder, and a service socket.

Casing suitable for flush mounting or surface mounting to the fume cupboard side frame

Scope of functions

- Configurable, optical and acoustic signalling of the safety-related functions
- Integral service socket for configuration and diagnosis

Special features

- Optical and acoustic signalling of the safety-related functions of the fume cupboard according to EN 14175
- Four indicator lights
- Function buttons for operating mode \dot{V}_{\max} (increased mode), alarm acknowledgement, and LonWorks commissioning
- LON bus service socket
- Power failure indication

Materials and surface

- Plastic casing

Configuration software

TCU-LON-II plug-in

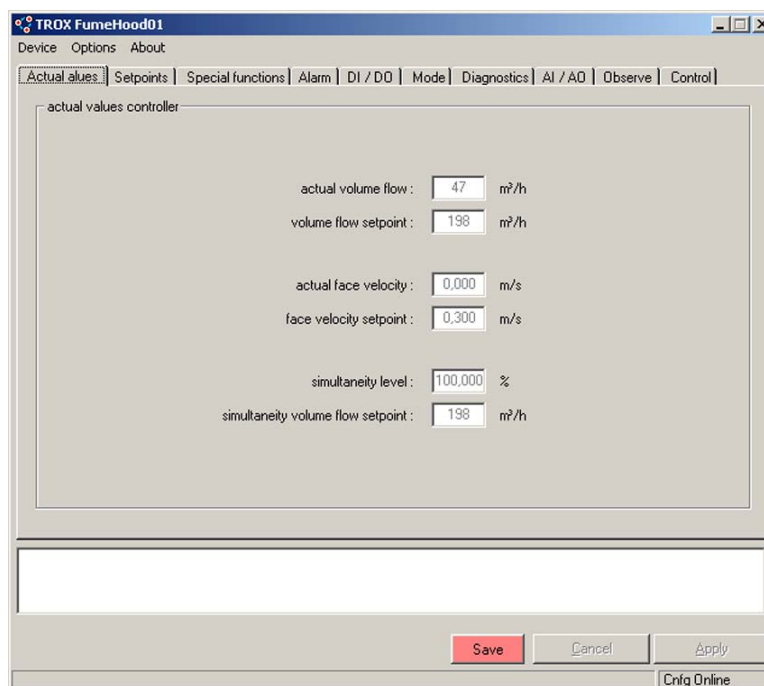

TCU-LON-II plug-in: Configuration software for the commissioning and diagnosis of TCU-LON-II

LNS plug-in for the configuration adjustment and diagnosis of TCU-LON-II controllers

- LNS-based, hence simple integration with network management tools such as Echelon LonMaker
- Display of actual operating values
- Menu-based navigation
- Device configuration
- Extensive diagnosis and diagram functions for simple commissioning and maintenance

Type		Page
TCU-LON-II plug-in	General information	2.6 – 2
	Basic information and nomenclature	2.7 – 1

Description



TCU-LON-II plug-in
(actual values)

Application

- LNS plug-in for the engineering tools that enables configuration and diagnosis of LABCONTROL controllers TCU-LON-II
- For LNS-based network management tools, e.g. Echelon LonMaker
- Access to all controllers within the LonWorks network
- Functions for the configuration, commissioning, test and fault diagnosis
- Upload/download and saving of data records

Variants

- TROX-RSRE01: for room supply air controllers and room extract air controllers, equipment functions RS, RE, PS, PE
- TROX-FH01: for fume cupboard controllers, equipment function FH
- TROX-FH_SF: for fume cupboard controllers with SecuFlow, equipment function FH

Special features

- Access to all controllers within the LonWorks network
- Display of actual operating values
- Configuration and adjustment of setpoint values
- Diagnosis
- Creating backup files
- Selection of dialogue language, selection of unit of measure for volume flow rate

Parts and characteristics

- LNS-based software for PCs
- Graphical user interface (Windows-based)
- Different views for groups of data, e.g. actual values, setpoint values, special functions, diagnosis

System requirements

PC or notebook

- Windows XP with SP3
- Windows Vista, SP2 or higher
- Windows 7 32-bit version
- LNS network management tool: Version 3 with SP 7 or higher, e.g. Echelon LonMaker
- Screen resolution 1024 × 768
- An interface adapter is required to access the LonWorks FTT-10A network (e.g. USB adapter or PCMCIA card)

Licensing

- No licence required for plug-ins

Installation and commissioning

- Install the LNS network management tool, e.g. Echelon LonMaker, if not yet installed
- Install Device Resource Files
- Install and register plug-in
- Carry out system integration (network creation), define devices, create bindings
- Access to the individual functional objects (e.g. LonMaker project) in the LNS database is now available

Function

The plug-in works in combination with a network management tool and displays values, parameters and functions on a graphical user interface (GUI).

- Display of actual operating values
- Configuration of controllers
- Diagnosis for all controller connections
- Backup function to restore the factory or commissioning settings

- Identification of programme users and hence documentation of configuration changes by user
- Dialogue language: English or German
- Unit of measure for volume flow rate: m³/h, l/s or cfm
- Controller configuration is saved in files and can be used to create a project database

TCU-LON-II plug-in (actual values)

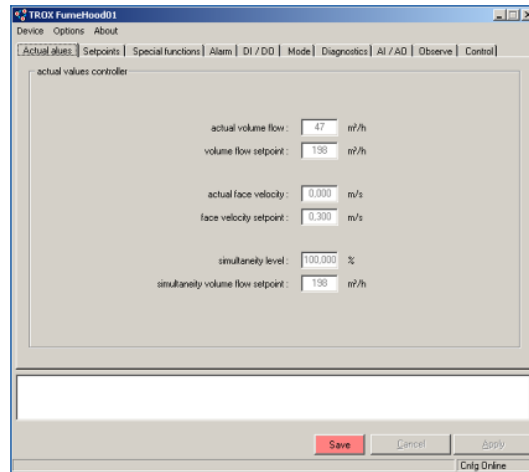

TCU-LON-II plug-in (diagnosis)

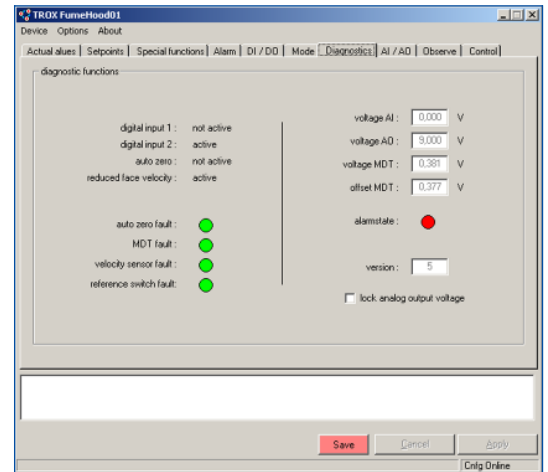

Order code

The TCU-LON-II plug-in is available on request.



Configuration software MConnect

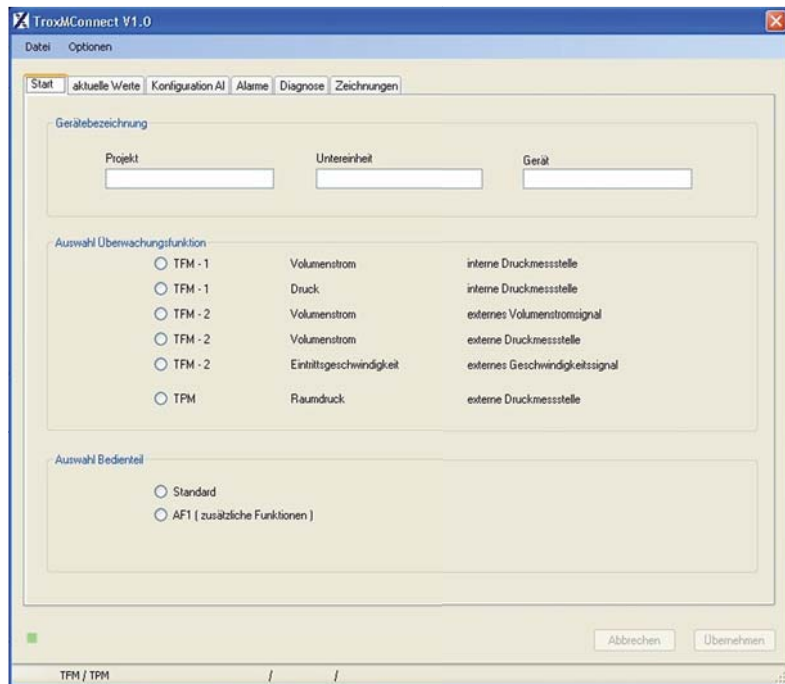

For the commissioning and diagnosis of TFM and TPM

Software for the configuration and diagnosis of monitoring systems TFM or TPM

- Display of the values being monitored
- Menu-based navigation
- Selection of values to be monitored and of alarms
- Configuration of additional functions
- Selection of dialogue language and of unit of measure for the volume flow rate

Type		Page
MConnect	General information	2.6 – 6
	Basic information and nomenclature	2.7 – 1

Description



MConnect configuration software

Application

- MConnect configuration software for use with monitoring devices TFM-1, TFM-2 and TPM
- PC software, available for download free of charge, to be used by customers
- Used for the configuration of monitoring devices for fume cupboards or rooms, monitoring of volume flow rate, face velocity, and differential pressure
- Functional testing and fault diagnosis
- Rapid documentation and creation of databases
- Upload/download and saving of data records

Useful additions

- MConnect-CAB: Plug-in cable for the connection of a monitoring device Type TFM or TPM to a computer

Special features

- Device configuration with graphical support
- Display of the operating values being monitored and of the actual values
- Monitoring of two independent values; the corresponding types of alarm can be set
- Special functions such as switch contacts for alarm suppression
- Creating backup files to build up a project database
- Selection of dialogue language, selection of unit of measure for volume flow rate

Parts and characteristics

- PC software
- Software communication via serial RS232 interface
- Graphical user interface (Windows-based)
- Based on the Microsoft.Net Framework (included in the software package)
- Different views, e.g. for monitoring, alarms, characteristics

System requirements

PC or notebook

- Windows XP with SP3
- Windows Vista, SP2 or higher
- Windows 7 32-bit version
- RS232 interface or USB interface with USB-RS232 adapter
- Screen resolution 1024 x 768

Licensing

- No licence required

Installation and commissioning

Prepare computer

- Download and install software
- Install driver for USB adapter, if necessary
- Start software and select communication port COMx
- Select dialogue language

Commissioning of the monitoring system

- Connect terminal cable
- Start software
- Open configuration or diagnosis window and carry out required actions

Function

- The software displays values, parameters and functions on a graphical user interface (GUI).
- Diagnosis for all connections of the monitoring device
 - Dialogue language: English or German

- Unit of measure for volume flow rate: m³/h or l/s
- Device configuration is saved in files and can be used to create a project database

MConnect configuration software

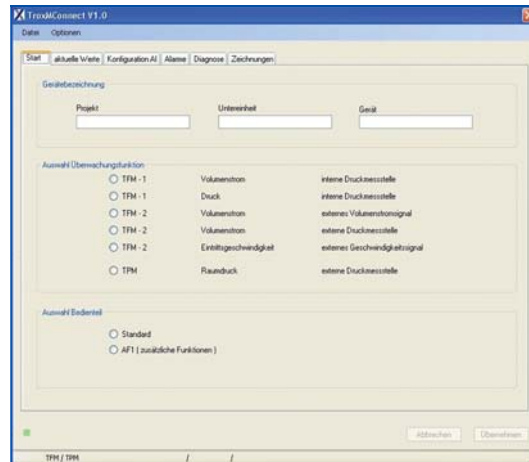

MConnect configuration software

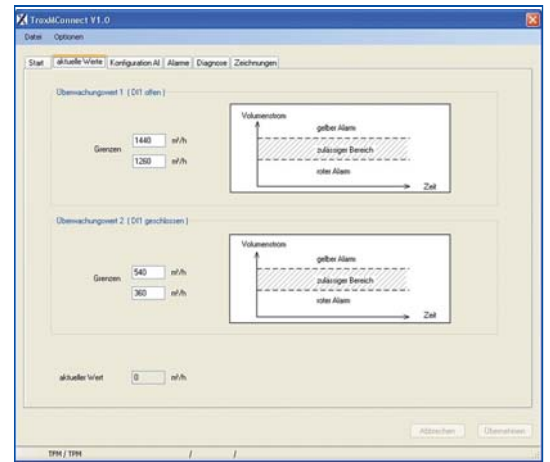

2

Order code

The MConnect software can be downloaded from our website free of charge.

Accessories for MConnect configuration software

MConnect – CAB

1

1 Accessories

MConnect-CAB Terminal cable for the connection of a monitoring system Type TFM or TPM to a computer

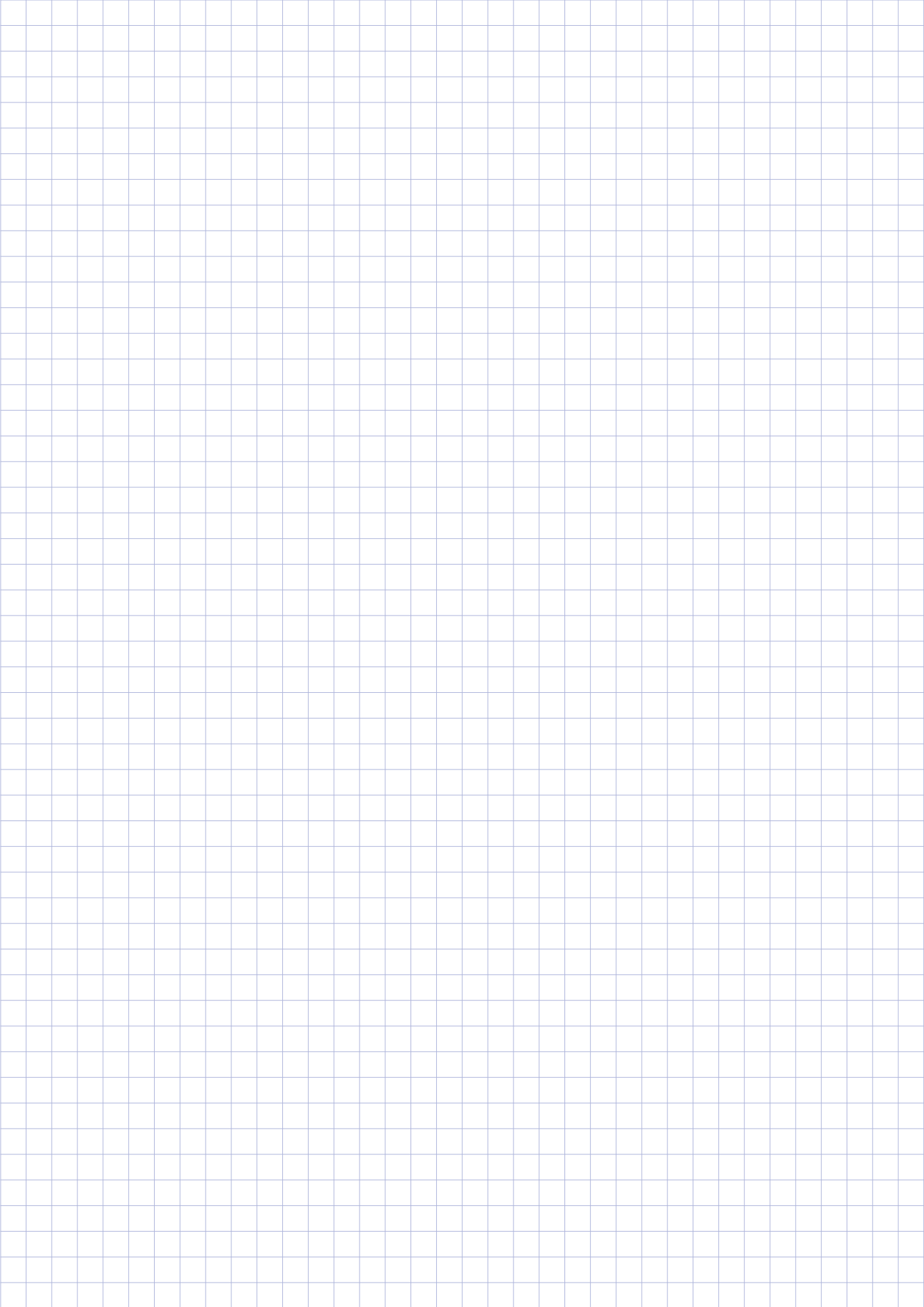

Configuration software

Type EasyConnect

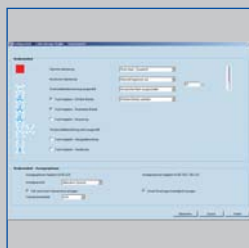

EasyConnect control panel

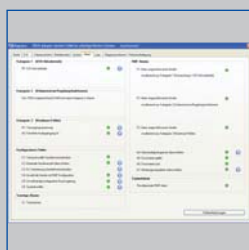

EasyConnect alarms

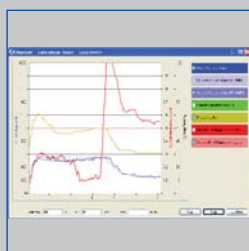

EasyConnect diagram

Parameter	Value
Volumenstrom	724 m³/h
Sollwert (GF = 100%)	720 m³/h
Sollwert (GF <= 100%)	720 m³/h
Istwert	724 m³/h
Klappenposition	0 % geöffnet

EasyConnect volume flow rates

Laborabzugs-Regler - EasyConnect

Gerätebezeichnung: TROX Geb. A1, Raum 251, Abzug 25, ID - 0

Betriebsart: Standard Betrieb

Frontschieberüberwachung EN 14175: Begrenzung unterschritten

Stützstrahl-Technologie: nicht konfiguriert

Regelungskonzept - Einstromsensor:

Sollwert	0,50	m/s
Istwert	0,60	m/s

Abluftwäscher: nicht konfiguriert

Entrauchungsfunktion: nicht konfiguriert

Volumenstrom:

Sollwert (GF = 100%)	720	m³/h
Sollwert (GF <= 100%)	720	m³/h
Istwert	724	m³/h
Klappenposition	0	% geöffnet

Gleichzeitigkeitsregelung:

Aktueller Zustand: Volumenstromreduzierung nicht wirksam

Gleichzeitigkeitsfaktor (GF): 100 %

Alarmstatus: Kein Alarm

USV-Funktion: nicht vorhanden

Bewegungsmelder: nicht konfiguriert

Erkannte EASYLAB Systemteilnehmer:

Gesamtanzahl	1
--------------	---

Serviceintervall:

Eingestelltes Serviceintervall	365	Tage
Zeitraum seit letztem Service	141	Tage

For the commissioning and diagnosis of EASYLAB components

Software for the configuration and diagnosis of controllers Type TCU3 and adapter modules TAM

- Display of actual operating values
- Interactive navigation
- Extensive diagnosis and diagram functions
- Creation of configuration protocols and backup files
- The software automatically recognises the controller type and displays the corresponding operating values and parameters
- Selection of dialogue language and of unit of measure for the volume flow rate
- Connecting cable and USB adapter are included in the supply package

Optional equipment and accessories

- Bluetooth adapter module BlueCON for wireless communication

Type		Page
EasyConnect	General information	2.6 – 10
	Basic information and nomenclature	2.7 – 1

Description



EasyConnect start window

Application

- EasyConnect configuration software for EASYLAB controllers TCU3 and adapter modules TAM
- Used to change the configuration of fume cupboard controllers, supply air or extract air controllers, differential pressure controllers, and adapter modules
- Extensive functions for configuration and commissioning
- Functions for test and fault diagnosis
- Documentation of configuration settings

Variants

- CAB: Configuration software with connecting cable and USB RS485 (cable connection)
- BC: Configuration software with Bluetooth adapter module BlueCON (wireless communication)

Special features

- Display of actual operating values
- Interactive navigation
- Extensive diagnosis and diagram functions
- Creation of configuration protocols and backup files
- Selection of dialogue language and of unit of measure for the volume flow rate
- Connecting cable and USB adapter are included in the supply package
- Optional Bluetooth adapter module BlueCON for wireless communication

Parts and characteristics

- PC software
- Interface adapter USB 2.0, RS485, including CD with driver software
- Plug-in cable
- PC side: 9-pin D-SUB socket; EASYLAB side: RJ45
- Graphical user interface (Windows-based)
- Based on the Microsoft.Net Framework (included in the software package)
- Commissioning wizard to facilitate adjustments to the controller configuration
- Access to configuration parameters can be restricted (read only)

System requirements

PC or notebook

- Windows XP with SP3
- Windows Vista, SP2 or higher
- Windows 7 32-bit and 64-bit versions
- USB or Bluetooth interface
- Screen resolution 800 × 600

Licensing

- Licence is valid for one computer
- Licence is linked to the hardware (licence key required)

Installation and commissioning

Prepare computer

- Install software
- Connect interface adapter USB-RS485
- Install driver for USB-RS485 from CD
- Request licence key and enter licence key
- Select communication port COMx

Commissioning of EASYLAB

- Connect EASYLAB controller or adapter module
- Start software
- Open configuration or diagnosis window and carry out required actions

Function

The software displays values, parameters and functions on a graphical user interface (GUI). The software automatically recognises the controller type and displays the corresponding operating values and parameters

- Display of actual operating values
- Display of room operating values on the controller with room management function
- Commissioning of individual controllers and room controllers (controllers with room management function), with commissioning wizard
- Diagnosis for all controller connections
- Graphical display of the most important operating values in a time diagram
- Backup function to restore the factory or commissioning settings
- Identification of programme users and hence documentation of configuration changes by user

- Dialogue language: English or German
- Unit of measure for volume flow rate: m³/h, l/s or cfm
- Device configuration is saved in files and can be used to create a project database
- Documentation of the controller configuration in a PDF protocol file with individual logo and letterhead data

It is possible to define different user groups with limited access to functions (defined by licence code). The software supports several levels of access rights.

- Display of actual operating values and diagnosis data
- Display and change of configuration data
- Change of service interval
- Backup function

EasyConnect start window

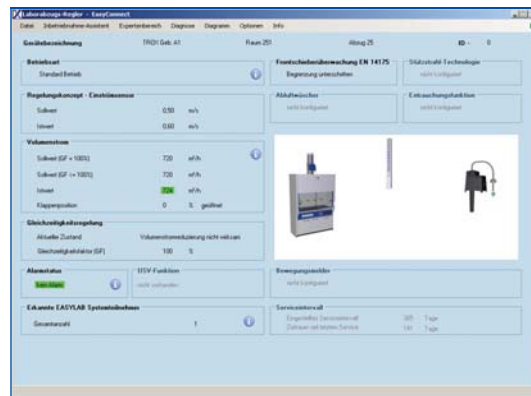

EasyConnect diagram

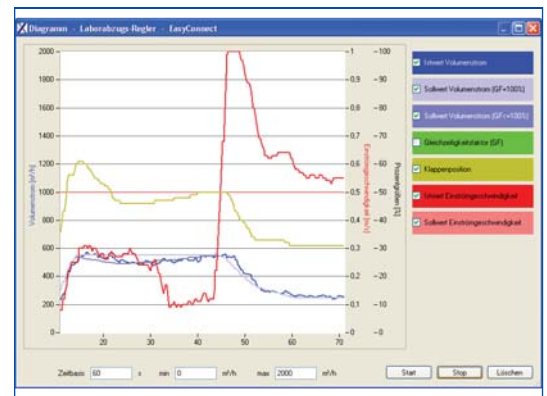

Order code

EasyConnect configuration software

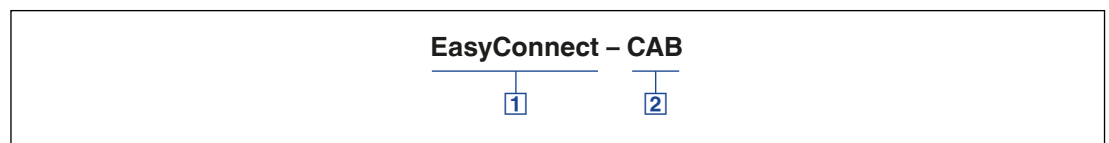

1 Software
EasyConnect Configuration software

2 Interface adapter
CAB USB-RS485 and connecting cable (cable connection)
BC Bluetooth adapter module BlueCON (wireless communication)



Air management control systems

Basic information and nomenclature

2





- Product selection

Air management control systems

Basic information and nomenclature

Product selection

	Control						Monitoring	
								
	System EASYLAB			System TCU-LON-II			TFM / TPM	
Area of application	Fume cupboard control	Room balancing	Room pressure control	Fume cupboard control	Room balancing	Room pressure control	TFM-1, TFM-2 Volume flow rate monitoring	TPM Room pressure monitoring
Hardware components								
Adapter module		●						
Expansion module for 230 V mains supply	Optional	Optional	Optional				Optional	
Expansion module for 230 V mains supply and UPS	Optional	Optional	Optional					
LonWorks interface	Optional	Optional	Optional	●	●	●		
Expansion module – solenoid valve	Optional	Optional	Optional	●	●	●		
Expansion module – fume cupboard lighting	Optional						●	
Control panel with 2-character display	●							
Control panel with 40-character display	●	●	●					
Control panel – TCU-LON-II standard				●			●	●
Control panel – expanded, AF-1							●	
Functions								
Monitoring – volume flow rate	●	●	●	●	●	●	●	
Monitoring – face velocity	●			●			Only with TFM-2	
Monitoring – sash position	●			●			●	
Monitoring – room pressure			●			●		●
Constant volume flow control	●	●		●	●			
Variable volume flow control	●	●		●	●			
Constant volume flow rate difference		●	●		●	●		
Room pressure control			●			●		
Room management function		●	●					
Additional functions								
Interface to central BMS	●	●	●	●	●	●	●	●
Damper blade position signal	●	●	●					
Diversity control		●	●		●	●		
Volume flow rate setpoint change		●	●		●	●		
Smoke extract	●							
Motion detector	●			●				
Control of automatic sash device	●						●	
Configuration software								
EasyConnect	●	●	●					
PlugIn TCU-LON II				●	●	●		
MConnect							●	●

● Possible

□ Not possible

Product index

BE-LCD-01	2.5 – 1	Basic information and nomenclature	
BE-SEG	2.5 – 9	VAV terminal units Secondary silencers for	
BE-TCU-LON-II	2.5 – 17	VAV terminal units	1.3 – 1
CAK	1.2 – 1	Basic information and nomenclature	
Differential pressure transducer	2.4 – 13	Air management control systems	2.7 – 1
DS-TRD-01	2.4 – 7	MConnect	2.6 – 5
EasyConnect	2.6 – 9	PlugIn TCU-LON-II	2.6 – 1
EASYPAC TCU3	2.1 – 1	TAM	2.1 – 27
EM-AUTOZERO	2.3 – 49	TCU-LON-II	2.1 – 39
EM-BAC-MOD-01	2.3 – 19	TFM-1	2.2 – 1
EM-LIGHT	2.3 – 53	TFM-2-TPM	2.2 – 7
EM-LON	2.3 – 1	TVLK	1.1 – 1
EM-TRF	2.3 – 39	VS-TRD	2.4 – 1
EM-TRF-USV	2.3 – 43		

Disclaimer

The information provided in this product catalogue is without obligation and does in particular not constitute a guarantee of the properties of a product. The described applications are not binding but are rather meant for general information as they may vary from case to case. The products and systems shown are examples. Some products and systems shown may have been designed for individual customers and hence represent customised solutions. Some of these products and systems come with special parts or equipment that is only available at a surcharge. Technical data is subject to change due to the results of ongoing research and development. The information regarding the scope of delivery, appearance, performance, dimensions, and weights was correct at the time of going to press. For up-to-date information please refer to our website www.troxtechnik.com. Subject to change. All rights reserved.

Feature requests are binding only if they are included in the sales contract. Terms of delivery and technical details are subject to change.

All business relationships with TROX GmbH are subject to our General Terms and Conditions valid at that time. These Terms and Conditions are available on our website http://www.troxtechnik.com/en/site_services/dpt/index.html. Alternatively, we will send them to you upon request.

This edition replaces all previous editions.

TROX Contact information



TROX[®] TECHNIK

The art of handling air

TROX GmbH

Heinrich-Trox-Platz
47504 Neukirchen-Vluyn

Phone +49 (0)2845 2020

Fax +49 (0)2845 202265

E-mail trox@trox.de

www.troxtechnik.com

TROX Germany

North branch

Hannover office

Bothfelder Straße 23
30916 Isernhagen, Germany
Phone +49 (0) 511 61003435
Fax +49 (0) 511 619820
E-mail nln@trox.de

South branch

Munich office

Liebigstraße 2
85301 Schweitenkirchen, Germany
Phone +49 (0) 8444 9250
Fax +49 (0) 8444 92510
E-mail nls@trox.de

Central branch

Frankfurt office

Kaiserleistraße 43
63067 Offenbach, Germany
Phone +49 (0) 69 985560
Fax +49 (0) 69 98556111
E-mail nlm@trox.de

Southwest branch

Stuttgart office

Hohentwielstraße 28
70199 Stuttgart, Germany
Phone +49 (0) 711 648620
Fax +49 (0) 711 6486220
E-mail nls@trox.de

West branch

Neukirchen-Vluyn office

Heinrich-Trox-Platz
47504 Neukirchen-Vluyn, Germany
Phone +49 (0) 2845 202611
Fax +49 (0) 2845 202612
E-mail nlw@trox.de

East branch

Berlin office

Rotherstraße 18
10245 Berlin, Germany
Phone +49 (0) 30 2618051
Fax +49 (0) 30 2629078
E-mail nlobb@trox.de

Dresden office

Zur Wetterwarte 50, Haus 337/G
01109 Dresden, Germany
Phone +49 (0) 351 889091112
Fax +49 (0) 351 8890910
E-mail nlobd@trox.de

TROX International

Subsidiaries

Argentina

TROX Argentina S.A.

Australia

TROX Australia Pty Ltd

Belgium

S.A. TROX Belgium N.V.

Brazil

TROX do Brasil Ltda.

Bulgaria

TROX Austria GmbH

China

TROX Air Conditioning Components
(Suzhou) Co., Ltd.

Denmark

TROX Danmark A/S

France

TROX France Sarl

Great Britain

TROX UK Ltd.

Hong Kong

TROX Hong Kong Ltd.

India

TROX INDIA Pvt. Ltd.

Italy

TROX Italia S.p.A.

Croatia

TROX Austria GmbH

Malaysia

TROX Malaysia Sdn. Bhd.

Mexico

TROX Mexico S.A. de C.V.

Netherlands

TROX Nederland B.V.

Norway

TROX Aurantor Norge AS

Austria

TROX Austria GmbH

Poland

TROX Austria GmbH

Romania

TROX Austria GmbH

Russia

OOO TROX RUS

Switzerland

TROX HESCO Schweiz AG

Serbia

TROX Austria GmbH

Spain

TROX España, S.A.

South Africa

TROX South Africa (Pty) Ltd

Czech Republic

TROX Austria GmbH

Turkey

TROX TURKEY LTD. STI.

Hungary

TROX Austria GmbH

USA

TROX USA, Inc.

United Arab Emirates

TROX Middle East (LLC)

Foreign representatives

Abu Dhabi

Egypt

Bosnia-Herzegovina

Finland

Greece

Indonesia

Ireland

Iceland

Israel

Latvia

Lithuania

Malta

Morocco

New Zealand

Oman

Pakistan

Philippines

Portugal

Sweden

Slovak Republic

Slovenia

South Korea

Taiwan

Thailand

Ukraine

Uruguay

Vietnam

Zimbabwe

Control Systems

2013

TROX[®] TECHNİK

The art of handling air

TROX GmbH

Heinrich-Trox-Platz

D-47504 Neukirchen-Vluyn

Phone +49(0)2845202-0

Fax +49(0)2845202-265

www.troxtechnik.com

www.trox.de

Subject to change · All rights reserved · © TROX GmbH